

11

Based on National Curriculum of Pakistan 2022-23

Model Textbook of

MATHEMATICS



National Book Foundation
as
Federal Textbook Board
Islamabad



National Book Foundation

Based on National Curriculum of Pakistan 2022-23

Model Textbook of
Mathematics

Science Group
Grade

11

National Curriculum Council

Ministry of Federal Education and Professional Training



National Book Foundation
as
Federal Textbook Board
Islamabad



© 2024 National Book Foundation as Federal Textbook Board, Islamabad
All rights reserved. This volume may not be reproduced in whole
or in part in any form (abridged, photo copy, electronic etc.)
without prior written permission from National Book Foundation

Model Textbook of **Mathematics**
for Grade 11



Authors

**Dr. Khalid Mahmood, Dr. Saleem Ullah Satti, M Dabeer Mughal,
Dr. Naveed Akmal, Dr. Shahzad Ahmad,**

Supervision

Dr. Mariam Chughtai

Director, National Curriculum Council
Ministry of Federal Education and Professional Training, Islamabad

IRC Members

Ms. Farkhanda Noor, Fazaia Teacher Training Institute Islamabad, M Ali Raza, Muhammad Anwar UI Haq, Naval Education Headquarter Islamabad, Zawar Hussain, Federal Government Educational Institutions (FGEI) (C/G) Regional Office Chaklala / Cantt, Tahira Bibi, Naval Education Headquarter Islamabad, Saadia Dawood Sobiha Kausar Toor, Federal Directorate of Education, Sobia Hasan, Fehmida Haroon, Federal Government Educational Institutions (FGEI) (C/G) Regional Office Chaklala / Cantt, Khalida Touqeer, Federal Directorate of Education, Shahzadi Kanwal Mehmood, Fazaia Teacher Training Institute Islamabad, Zafar Ali

IPCW-1 Members

Mr. Gul Muhammad, School Edu Department Bolochistan, Mr. Abbas Khan, Directorate Of Curriculum and Teacher Education Khyber Pakhtunkhwa Abbottabad, Ghulam Muratza Khan, Azad Government Of Jammu & Kashmir Directorate Of Curriculum Research & Development, Zawar Hussain, Federal Government Educational Institutions (FGEI) (C/G) Regional Office Chaklala / Cantt

M. Muhammad Anwar-ul-haq, Naval Education Naval Headquarter Islamabad, Mr. Ahmed Khan Zaur, Government of Sindh, School Education & Literacy Department, Mr. Ali Ahmad Khan, Government Of Gilgit Baltistan, Directorate Of Education, Mr. Muhammad Akhtar Shirani, Punjab Curriculum & Textbook Board

Desk Officer: Shazia Abbasi

Management: National Book Foundation

First Edition - First Impression: March 2024 | **Pages:** 284 | **Quantity:** 24000

Price: PKR 510/-

Code: STE-692, **ISBN:** 978-969-37-1604-7

Printer: Amir Enterprises, Peshawar



Note: All the pictures, paintings and sketches used in this book are only
for educational and promotional purpose in public interest.

for information about other publications of National Book Foundation,
visit our Web Site: www.nbf.org.pk or Phone: 051-9261125
or E-mail: books@nbf.org.pk
to share feedback or correction, please send us an email to nbftextbooks@gmail.com

Preface

This Model Textbook for Mathematics Grade 11 has been developed by NBF according to the National Curriculum of Pakistan 2022-2023. The aim of this textbook is to enhance learning abilities through inculcation of logical thinking in learners, and to develop higher order thinking processes by systematically building the foundation of learning from the previous grades. A key emphasis of the present textbook is creating real life linkage of the concepts and methods introduced. This approach was devised with the intent of enabling students to solve daily life problems as they grow up in the learning curve and also to fully grasp the conceptual basis that will be built in subsequent grades.

After amalgamation of the efforts of experts and experienced authors, this book was reviewed and finalized after extensive reviews by professional educationists. Efforts were made to make the contents student friendly and to develop the concepts in interesting ways.

The National Book Foundation is always striving for improvement in the quality of its textbooks. The present textbook features an improved design, better illustration and interesting activities relating to real life to make it attractive for young learners. However, there is always room for improvement, the suggestions and feedback of students, teachers and the community are most welcome for further enriching the subsequent editions of this textbook.

May Allah guide and help us (Ameen).

Dr. Raja Mazhar Hameed
Managing Director

بِسْمِ اللّٰهِ الرَّحْمٰنِ الرَّحِیْمِ
اللہ کے نام سے شروع جو بڑا مہربان، نہایت رحم والا ہے

CONTENT

| | | |
|--------|---|-----|
| Unit 1 | Complex Numbers | 05 |
| Unit 2 | Matrices and Determinants | 32 |
| Unit 3 | Vectors | 80 |
| Unit 4 | Sequences and Series | 121 |
| Unit 5 | Polynomials | 161 |
| Unit 6 | Permutation and Combination | 173 |
| Unit 7 | Mathematical Induction and Binomial Theorem | 186 |
| Unit 8 | Fundamentals of Trigonometry | 207 |
| Unit 9 | Trigonometric Functions | 228 |
| | Answers, Glossary and Index | 261 |

UNIT
01

COMPLEX NUMBERS

After studying this unit, students will be able to:

- Recall complex number z and recognize its real and imaginary part.
- Know the condition for equality of two complex numbers.
- Revising the basic operations on complex numbers.
- Find conjugate and modulus of a complex number.
- Solve the simultaneous linear equations with complex coefficients.
- Factorize the given polynomials like $z^2 + a^2$ or $z^3 - 3z^2 + z = 5$
- Solve quadratic equation of the form $pz^2 + qz + r = 0$, by completing squares, where p, q, r are real numbers and z is a complex number.
- Represent complex numbers in polar coordinates.
- Applying the binary operations in polar form.
- Solve complex equations and inequations in polar form.
- Using the complex numbers in real world problems.

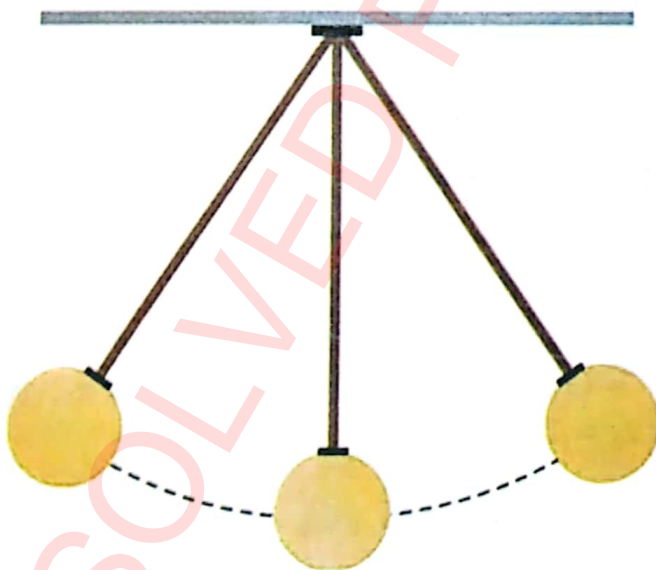

Complex numbers are used in many branches of science; especially quantum mechanics (a branch of Physics) heavily depends upon complex numbers.

In mathematics the need of complex numbers is to solve the polynomials which do not have the solution in the set of real numbers. e.g., The polynomial $x^2 - 1 = 0$ has the solutions $x = \pm 1$, which are the real numbers. But the polynomial $x^2 + 1 = 0$ do not have any solution in the set of real numbers, since there is no real number, whose square is -1 . To overcome this difficulty, we extended the set of real numbers to the set of complex numbers by introducing a number i such that $i^2 = -1$ or $i = \sqrt{-1}$. Remember that $i^2 = -1$ is the Euler's notation for the imaginary unit number.

1.1 Complex Number

A complex number is an expression of the form $x + iy$ where $x, y \in \mathbb{R}$. A complex number is denoted by z , i.e., $z = x + iy$ and the set of all complex numbers is denoted by \mathbb{C} . The complex number $x + iy$ is also denoted by the ordered pair (x, y) . The reason for this notation is justified since there is one to one corresponding between $x + iy$ and (x, y) .

Clearly $i = 0 + i = (0, 1)$ and $1 = 1 + 0i = (1, 0)$

1.1.1 Real and Imaginary Parts of a Complex Number

Every complex number $x + iy$ has two parts x and y . x is called the real part and y is called the imaginary part i.e., $Re(z) = x$ and $Im(z) = y$.

If the real part of a complex number is zero then it is called pure imaginary number and if the imaginary part of the complex number is zero then it is called real number.

Since every real number x can be written as $x + i0$ thus every real number is a complex number but note that every complex number need not be a real number. Only the complex numbers with zero imaginary part are real numbers. Thus, the set of real number is a subset of set of complex numbers, i.e., $\mathbb{R} \subset \mathbb{C}$.

1.1.2 Condition for the Equality of Two Complex Numbers

Like real numbers any two complex numbers are not comparable. i.e., We cannot say that one complex number is greater than or less than the other complex number. Two complex numbers are said to be equal if both has same real and imaginary parts.

1.2 Basic Algebraic Operations on Complex Numbers

1.2.1 Addition of Two Complex Numbers

Suppose we have two complex numbers $z_1 = x_1 + iy_1 = (x_1, y_1)$ and $z_2 = x_2 + iy_2 = (x_2, y_2)$. Then their sum is:

$$\begin{aligned} z_1 + z_2 &= (x_1, y_1) + (x_2, y_2) = x_1 + iy_1 + x_2 + iy_2 \\ &= (x_1 + x_2) + i(y_1 + y_2) = (x_1 + x_2, y_1 + y_2) \end{aligned}$$

Example: Find the sum of $z_1 = 2 + 3i$ and $z_2 = 6 + 8i$.

Solution:

$$\begin{aligned} z_1 + z_2 &= (2 + 3i) + (6 + 8i) = (2 + 6) + (3 + 8)i \\ &= 8 + 11i = (8, 11) \end{aligned}$$

1.2.2 Subtraction of Two Complex Numbers

Suppose we have two complex numbers $z_1 = x_1 + iy_1 = (x_1, y_1)$ and $z_2 = x_2 + iy_2 = (x_2, y_2)$. The difference of the two complex numbers is given by:

$$\begin{aligned} z_1 - z_2 &= (x_1, y_1) - (x_2, y_2) = (x_1 + iy_1) - (x_2 + iy_2) \\ &= (x_1 - x_2) + i(y_1 - y_2) = (x_1 - x_2, y_1 - y_2) \end{aligned}$$

Example: If $z_1 = 4 - 3i$ and $z_2 = 7 + 6i$, then find $z_1 - z_2$.

Solution:

$$\begin{aligned} z_1 - z_2 &= (4 - 3i) - (7 + 6i) = (4 - 7) + (-3 - 6)i \\ &= -3 + (-9i) = -3 - 9i \end{aligned}$$

1.2.3 Product of Two Complex Numbers

If $z_1 = x_1 + iy_1 = (x_1, y_1)$ and $z_2 = x_2 + iy_2 = (x_2, y_2)$ are any two complex numbers, then their product is given as:

$$\begin{aligned} z_1 z_2 &= (x_1, y_1)(x_2, y_2) = (x_1 + iy_1)(x_2 + iy_2) \\ &= x_1 x_2 + ix_1 y_2 + ix_2 y_1 + i^2 y_1 y_2 = x_1 x_2 + i(x_1 y_2 + x_2 y_1) - y_1 y_2 \\ &= (x_1 x_2 - y_1 y_2) + i(x_1 y_2 + x_2 y_1) = (x_1 x_2 - y_1 y_2, x_1 y_2 + x_2 y_1) \end{aligned}$$

Example: Find the product of the complex numbers $z_1 = (2, -6)$ and $z_2 = (4, 9)$

Solution:

$$\begin{aligned} z_1 z_2 &= (2, -6)(4, 9) = (2 - 6i)(4 + 9i) \\ &= 8 + 18i - 24i - 54i^2 = 8 - 6i - (-54) \\ &= 8 + 54 - 6i = 62 - 6i = (62, -6) \end{aligned}$$

1.2.4 Division of Complex Numbers

The division of the two complex numbers is not simple. Since the number in the denominator has two independent parts. To make the denominator a single term we rationalize (multiply and divide) the given complex number by the conjugate of the denominator. After rationalization the denominator will be converted into a single real number and thus division can be done easily.

If $z_1 = x_1 + iy_1 = (x_1, y_1)$ and $z_2 = x_2 + iy_2 = (x_2, y_2)$, are any two complex numbers, then

$$\begin{aligned} \frac{z_1}{z_2} &= \frac{(x_1, y_1)}{(x_2, y_2)} = \frac{x_1 + iy_1}{x_2 + iy_2} \\ &= \frac{(x_1 + iy_1)(x_2 - iy_2)}{(x_2 + iy_2)(x_2 - iy_2)} = \frac{x_1 x_2 - ix_1 y_2 + ix_2 y_1 - i^2 y_1 y_2}{x_2^2 - ix_2 y_2 + ix_2 y_2 - i^2 y_2^2} \\ &= \frac{x_1 x_2 + i(x_2 y_1 - x_1 y_2) + y_1 y_2}{x_2^2 + y_2^2} = \frac{(x_1 x_2 + y_1 y_2) + i(x_2 y_1 - x_1 y_2)}{x_2^2 + y_2^2} \\ &= \frac{x_1 x_2 + y_1 y_2}{x_2^2 + y_2^2} + i \frac{x_2 y_1 - x_1 y_2}{x_2^2 + y_2^2} = \left(\frac{x_1 x_2 + y_1 y_2}{x_2^2 + y_2^2}, \frac{x_2 y_1 - x_1 y_2}{x_2^2 + y_2^2} \right) \end{aligned}$$

Example: If $z_1 = 3 + 7i$ and $z_2 = -4 + 6i$, then find the sum, difference, product and quotient of the two complex numbers.

Solution:

$$\begin{aligned} z_1 + z_2 &= (3 + 7i) + (-4 + 6i) = (3 - 4) + (7 + 6)i = -1 + 13i \\ z_1 - z_2 &= (3 + 7i) - (-4 + 6i) = 3 + 7i + 4 - 6i = (3 + 4) + (7 - 6)i = 7 + i \\ z_1 z_2 &= (3 + 7i)(-4 + 6i) = 3(-4) + 3(6i) + (7i)(-4) + (7i)(6i) \\ &= -12 + 18i - 28i + 42i^2 = -12 - 10i - 42 \\ &= -54 - 10i \end{aligned}$$

$$\begin{aligned} \frac{z_1}{z_2} &= \frac{3 + 7i}{-4 + 6i} = \frac{(3 + 7i)(-4 - 6i)}{(-4 + 6i)(-4 - 6i)} = \frac{-12 - 18i - 28i - 42i^2}{(-4)^2 - (6i)^2} \\ &= \frac{-12 - 46i + 42}{16 - 36i^2} = \frac{30 - 46i}{16 + 36} = \frac{30 - 46i}{52} \\ &= \frac{30}{52} - \frac{46}{52}i = \frac{15}{26} - \frac{23}{26}i \end{aligned}$$

Example: Write the complex number $\frac{(2+3i)(2+i)}{1-i}$ in the form $x + iy$.

Solution:
$$\frac{(2+3i)(2+i)}{1-i} = \frac{4+2i+6i+3i^2}{1-i} = \frac{4+8i-3}{1-i}$$

$$= \frac{1+8i}{1-i} = \frac{1+8i}{1-i} \times \frac{1+i}{1+i} = \frac{1+i+8i+8i^2}{1^2-i^2}$$

$$= \frac{1+9i-8}{1-(-1)} = \frac{-7+9i}{2} = \frac{-7}{2} + \frac{9i}{2}$$

Example: Find the values of x and y if, $\frac{x}{2+3i} - y(1+2i) = 1+i$

Solution:

$$\frac{x}{2+3i} - y(1+2i) = 1+i$$

$$\Rightarrow \frac{x(2-3i)}{(2+3i)(2-3i)} - y(1+2i) = 1+i$$

$$\Rightarrow \frac{2x-3xi}{(2)^2 - (3i)^2} - y(1+2i) = 1+i$$

$$\Rightarrow \frac{2x-3xi}{4-9i^2} - y(1+2i) = 1+i$$

$$\Rightarrow \frac{2x-3xi}{13} - y(1+2i) = 1+i$$

$$\Rightarrow \frac{2x}{13} - \frac{3ix}{13} - y - 2iy = 1+i$$

$$\Rightarrow \left(\frac{2x}{13} - y\right) - \left(\frac{3x}{13} + 2y\right)i = 1+i$$

Comparing real and imaginary parts

$$\frac{2x}{13} - y = 1 \tag{1}$$

$$\text{and } -\frac{3x}{13} - 2y = 1 \tag{2}$$

Multiplying equation (1) with 2 then adding them, we get:

$$\begin{array}{r} \frac{4x}{13} - 2y = 2 \\ \frac{3x}{13} + 2y = -1 \\ \hline \frac{7x}{13} = 1 \end{array}$$

$$x = \frac{13}{7}$$

Putting value of x in equation (1), $\frac{2}{13} \times \frac{13}{7} - y = 1$

$$\frac{2}{7} - y = 1 \Rightarrow -y = 1 - \frac{2}{7} = \frac{7-2}{7}$$

$$y = -\frac{5}{7}$$

1.3 Conjugate of a Complex Number

Conjugate of a complex number $z = x + iy$ is denoted by \bar{z} and is defined as $\bar{z} = x - iy$.

Geometrically, conjugate of a complex number is its mirror image about x -axis. For example, if $z = 3 + 4i$ then $\bar{z} = 3 - 4i$.

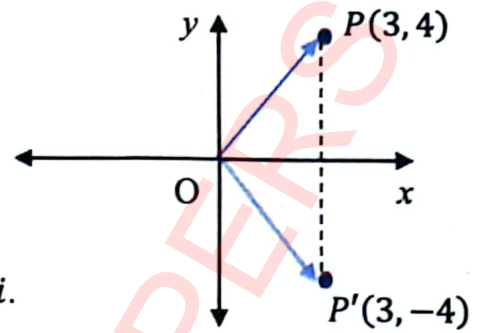

Example: Find the conjugate of $z = (1 + i)(2 - i)$.

Solution:

$$z = (1 + i)(2 - i) = 2 - i + 2i - i^2 = 2 + i + 1 = 3 + i$$

Now $\bar{z} = \overline{3 + i} = 3 - i$

Key Facts

$$\overline{z_1 z_2} = \bar{z}_1 \bar{z}_2$$

$$\overline{\left(\frac{z_1}{z_2}\right)} = \frac{\bar{z}_1}{\bar{z}_2}$$

1.4 Magnitude or Modulus of a Complex Number

Draw a complex number $z = x + iy = (x, y)$ on the complex plane.

Draw perpendicular from P on the real axis.

It is clear that $\triangle POA$ is a right-angled triangle.

So, by using Pythagoras theorem; we have

$$|\overline{OP}|^2 = |\overline{OA}|^2 + |\overline{AP}|^2$$

$$\Rightarrow |z|^2 = x^2 + y^2$$

$$\Rightarrow |z| = \sqrt{x^2 + y^2}$$

which is the magnitude of the complex number z .

$$\text{Also, } |z| = \sqrt{(\text{Re}(z))^2 + (\text{Im}(z))^2}$$

Obviously $|z|$ is the distance of $z = (x, y)$ from origin.

Example: Find the conjugate and magnitude of $z = \frac{(3+2i)(1-2i)}{4+3i}$

Solution:

$$\begin{aligned} \bar{z} &= \overline{\left[\frac{(3 + 2i)(1 - 2i)}{4 + 3i}\right]} = \frac{\overline{(3 + 2i)(1 - 2i)}}{\overline{(4 + 3i)}} = \frac{(3 - 2i)(1 + 2i)}{4 - 3i} \\ &= \frac{3 + 6i - 2i - 4i^2}{4 - 3i} = \frac{3 + 4 + 4i}{4 - 3i} = \frac{7 + 4i}{4 - 3i} \times \frac{4 + 3i}{4 + 3i} \\ &= \frac{28 + 21i + 16i + 12i^2}{4^2 - (3i)^2} = \frac{28 - 12 + 37i}{16 - 9i^2} = \frac{16 + 37i}{25} = \frac{16}{25} + \frac{37}{25}i \end{aligned}$$

And

$$\begin{aligned} |z| &= \left| \frac{(3 + 2i)(1 - 2i)}{4 + 3i} \right| = \frac{|3 + 2i||1 - 2i|}{|4 + 3i|} \\ &= \frac{\sqrt{3^2 + 2^2} \sqrt{1^2 + (-2)^2}}{\sqrt{4^2 + 3^2}} = \frac{\sqrt{13}\sqrt{5}}{\sqrt{25}} \\ &= \frac{\sqrt{65}}{5} \end{aligned}$$

Key Facts

$$|z_1 z_2| = |z_1| |z_2|$$

$$\left| \frac{z_1}{z_2} \right| = \frac{|z_1|}{|z_2|}$$

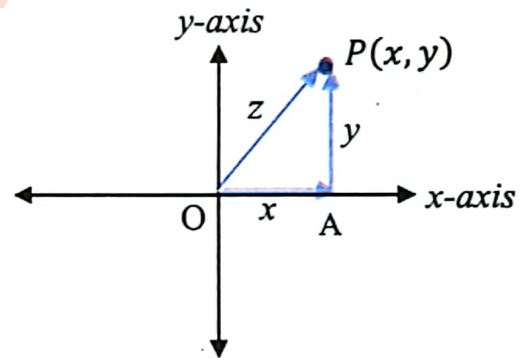

Theorem:

If z is a complex number then $|z| \geq 0$ and $|z| = 0$ iff $z = 0$.

Proof: Let $z = x + iy$; then $|z| = \sqrt{x^2 + y^2}$, where x and y are real. Since the square of any real number is always non-negative. Thus, value of $x^2 + y^2$ is non-negative, also square-root of the non-negative number is non-negative. Hence $\sqrt{x^2 + y^2}$ is non-negative; i.e.; $|z| \geq 0$.

Now suppose that $|z| = 0$

$$\Rightarrow \sqrt{x^2 + y^2} = 0 \Rightarrow x^2 + y^2 = 0$$

Which is possible only if $x = 0$ and $y = 0$

Thus $z = x + iy = 0 + i0 = 0$

Conversely, suppose that $z = 0 = 0 + i0$

$$\Rightarrow |z| = \sqrt{0^2 + 0^2} = 0$$

Key Facts



In order to calculate conjugate of a complex number we may simplify it first then take conjugate or we take first conjugate than simplify the complex number.

Exercise 1.1

1. Evaluate the following:

(i) i^{31} (ii) $(-i)^6$ (iii) $(-1)^{\frac{-13}{2}}$ (iv) $\frac{2}{(-1)^{\frac{3}{2}}}$ (v) $i^{23} + i^{58} + i^{21}$

2. Write the following complex numbers in the form $x + iy$.

(i) $(3 + 2i) + (2 + 4i)$ (ii) $(4 + 3i) - (2 + 5i)$ (iii) $(4 + 7i) + (4 - 7i)$
 (iv) $(2 + 5i) - (2 - 5i)$ (v) $(3 + 2i)(4 - 3i)$ (vi) $(3, 2) \div (3, -1)$
 (vii) $(1 + i)(1 - i)(2 + i)$ (viii) $\frac{1}{2+3i}$

3. Simplify the following:

(i) $\frac{(2+i)(3-2i)}{1+i}$ (ii) $\frac{1+i}{(2+i)^2}$ (iii) $\frac{1}{3+i} - \frac{1}{3-i}$
 (iv) $(1 + i)^{-2} + (1 - i)^{-2}$ (v) $(2 + i)^2 + \frac{7-4i}{2+i}$

4. Find the values of the real numbers x and y in each of the following:

(i) $(2 + 3i)x + (1 + 3i)y + 2 = 0$ (ii) $\frac{x}{1+i} + \frac{y}{1-2i} = 1$
 (iii) $\frac{x}{2+i} = \frac{1-5i}{3-2i} + \frac{y}{2-i}$ (iv) $x(1 + i)^2 + y(2 - i)^2 = 3 + 10i$

5. Find the complex number z if $4z - 3\bar{z} = \frac{1-18i}{2-i}$

6. Find the conjugate of the following complex numbers:

(i) $4 - 3i$ (ii) $3i + 8$ (iii) $2 + \sqrt{\frac{-1}{5}}$ (iv) $\frac{5i}{2} - \frac{7}{8}$

7. Find the magnitude of the following complex numbers:

(i) $11 + 12i$ (ii) $(2 + 3i) - (2 + 6i)$ (iii) $(2 - i)(6 + 3i)$
 (iv) $\frac{3-2i}{2+i}$ (v) $(\sqrt{3} - \sqrt{-8})(\sqrt{3} + \sqrt{-8})$

1.5 Real and Imaginary Parts of the Complex Numbers of the Types

- (i) $(x + iy)^n$; $n = \pm 1, \pm 2$
 (ii) $\left(\frac{x_1 + iy_1}{x_2 + iy_2}\right)^n$; $x_2 + iy_2 \neq 0$; $n = \pm 1, \pm 2$

Type-I Consider the complex number of the type $(x + iy)^n$.

When $n = 1$

$$z = x + iy$$

$$\text{Its real part} = x = \text{Re}(z)$$

$$\text{Imaginary part} = y = \text{Im}(z)$$

When $n = -1$

$$\begin{aligned} z^{-1} &= (x + iy)^{-1} = \frac{1}{x + iy} = \left(\frac{1}{x + iy}\right) \left(\frac{x - iy}{x - iy}\right) = \frac{x - iy}{x^2 - i^2 y^2} \\ &= \frac{x}{x^2 + y^2} - i \frac{y}{x^2 + y^2} \end{aligned}$$

$$\text{Thus } \text{Re}(x + iy)^{-1} = \text{Re}z^{-1} = \frac{x}{x^2 + y^2} = \frac{\text{Re}(z)}{|z|^2}$$

$$\text{Im}(x + iy)^{-1} = \text{Im}z^{-1} = \frac{-y}{x^2 + y^2} = -\frac{\text{Im}(z)}{|z|^2}$$

When $n = 2$

$$\begin{aligned} z^2 &\Rightarrow (x + iy)^2 = x^2 + 2ixy + i^2 y^2 \\ &= x^2 + 2ixy - y^2 = x^2 - y^2 + 2ixy \end{aligned}$$

$$\text{Re}(x + iy)^2 = \text{Re}(z)^2 = x^2 - y^2 = (\text{Re}(z))^2 - (\text{Im}(z))^2$$

$$\text{Im}(x + iy)^2 = \text{Im}(z)^2 = 2xy = 2\text{Re}(z)\text{Im}(z)$$

When $n = -2$

$$\begin{aligned} z^{-2} &= (x + iy)^{-2} = \frac{1}{(x + iy)^2} = \left(\frac{1}{x + iy}\right)^2 = \left(\frac{1}{x + iy} \cdot \frac{x - iy}{x - iy}\right)^2 \\ &= \left(\frac{x - iy}{x^2 - i^2 y^2}\right)^2 = \frac{x^2 + i^2 y^2 - 2ixy}{(x^2 + y^2)^2} = \frac{x^2 - y^2}{(x^2 + y^2)^2} + i \frac{2xy}{(x^2 + y^2)^2} \end{aligned}$$

$$\text{Re}(x + iy)^{-2} = \text{Re}(z)^{-2} = \frac{x^2 - y^2}{(x^2 + y^2)^2} = \frac{(\text{Re}(z))^2 - (\text{Im}(z))^2}{|z|^4}$$

$$\text{Im}(x + iy)^{-2} = \text{Im}(z)^{-2} = \frac{-2xy}{(x^2 + y^2)^2} = \frac{-2\text{Re}(z)\text{Im}(z)}{|z|^4}$$

Example: Find the real and imaginary parts of the following.

- (i) $3 + 4i$ (ii) $(3 + 4i)^{-1}$ (iii) $(3 + 4i)^2$ (iv) $(3 + 4i)^{-2}$

Solution: Let $z = 3 + 4i$

(i) $\text{Re}(3 + 4i) = \text{Re}(z) = 3$

$\text{Im}(3 + 4i) = \text{Im}(z) = 4$

(ii) $\text{Re}(3 + 4i)^{-1} = \text{Re}(z)^{-1} = \frac{\text{Re}(z)}{|z|^2} = \frac{3}{(\sqrt{3^2 + 4^2})^2} = \frac{3}{25}$

$$\operatorname{Im}(3 + 4i)^{-1} = \operatorname{Im}(z)^{-1} = \frac{-\operatorname{Im}(z)}{|z|^2} = \frac{-4}{(\sqrt{3^2 + 4^2})^2} = \frac{-4}{25}$$

$$\begin{aligned} \text{(iii)} \quad \operatorname{Re}(3 + 4i)^2 &= \operatorname{Re}(z)^2 = (\operatorname{Re}(z))^2 - (\operatorname{Im}(z))^2 \\ &= 3^2 - 4^2 = 9 - 16 = -7 \end{aligned}$$

$$\begin{aligned} \operatorname{Im}(3 + 4i)^2 &= \operatorname{Im}(z)^2 = 2\operatorname{Re}(z)\operatorname{Im}(z) \\ &= 2(3)(4) = 24 \end{aligned}$$

$$\text{(iv)} \quad \operatorname{Re}(3 + 4i)^{-2} = \operatorname{Re}(z)^{-2} = \frac{(\operatorname{Re}(z))^2 - (\operatorname{Im}(z))^2}{|z|^4} = \frac{3^2 - 4^2}{(\sqrt{3^2 + 4^2})^4} = \frac{9 - 16}{5^4} = \frac{-7}{625}$$

$$\operatorname{Im}(3 + 4i)^{-2} = \operatorname{Im}(z)^{-2} = \frac{-2\operatorname{Re}(z)\operatorname{Im}(z)}{|z|^4} = \frac{-2(3)(4)}{(\sqrt{3^2 + 4^2})^4} = \frac{-24}{5^4} = \frac{-24}{625}$$

Type-II Consider the complex number of the form $\left(\frac{x_1 + iy_1}{x_2 + iy_2}\right)^n$; where $x_2 + iy_2 \neq 0$.

Let $z_1 = x_1 + iy_1$; $z_2 = x_2 + iy_2$

So $\left(\frac{x_1 + iy_1}{x_2 + iy_2}\right)^n = \left(\frac{z_1}{z_2}\right)^n$ where $z_2 \neq 0$.

Key Facts



$\operatorname{Re}(z_1)\operatorname{Re}(z_2) \neq \operatorname{Re}(z_1 z_2)$
 $\operatorname{Im}(z_1)\operatorname{Im}(z_2) \neq \operatorname{Im}(z_1 z_2)$

When $n = 1$

$$\begin{aligned} \left(\frac{x_1 + iy_1}{x_2 + iy_2}\right)^n &= \frac{x_1 + iy_1}{x_2 + iy_2} = \frac{(x_1 + iy_1)(x_2 - iy_2)}{(x_2 + iy_2)(x_2 - iy_2)} \\ &= \frac{x_1 x_2 - ix_1 y_2 + ix_2 y_1 - i^2 y_1 y_2}{(x_2)^2 - (iy_2)^2} = \frac{x_1 x_2 + i(x_2 y_1 - x_1 y_2) + y_1 y_2}{x_2^2 - i^2 y_2^2} \\ &= \frac{(x_1 x_2 + y_1 y_2) + i(x_2 y_1 - x_1 y_2)}{x_2^2 + y_2^2} = \frac{(x_1 x_2 + y_1 y_2)}{x_2^2 + y_2^2} + i \frac{(x_2 y_1 - x_1 y_2)}{x_2^2 + y_2^2} \end{aligned}$$

$$\therefore \operatorname{Re}\left(\frac{x_1 + iy_1}{x_2 + iy_2}\right) = \operatorname{Re}\left(\frac{z_1}{z_2}\right) = \frac{(x_1 x_2 + y_1 y_2)}{x_2^2 + y_2^2}$$

$$\operatorname{Re}\left(\frac{x_1 + iy_1}{x_2 + iy_2}\right) = \frac{(\operatorname{Re}(z_1))(\operatorname{Re}(z_2)) + (\operatorname{Im}(z_1))(\operatorname{Im}(z_2))}{|z_2|^2}$$

$$\operatorname{Im}\left(\frac{x_1 + iy_1}{x_2 + iy_2}\right) = \operatorname{Im}\left(\frac{z_1}{z_2}\right) = \frac{(x_2 y_1 - x_1 y_2)}{x_2^2 + y_2^2}$$

$$\operatorname{Im}\left(\frac{x_1 + iy_1}{x_2 + iy_2}\right) = \frac{(\operatorname{Im}(z_1))(\operatorname{Re}(z_2)) + (\operatorname{Re}(z_1))(\operatorname{Im}(z_2))}{|z_2|^2}$$

When $n = -1$

$$\begin{aligned} \left(\frac{x_1 + iy_1}{x_2 + iy_2}\right)^{-1} &= \left(\frac{x_1 + iy_1}{x_2 + iy_2}\right)^{-1} = \frac{x_2 + iy_2}{x_1 + iy_1} = \frac{x_2 + iy_2}{x_1 + iy_1} \cdot \frac{x_1 - iy_1}{x_1 - iy_1} \\ &= \frac{x_1 x_2 + ix_1 y_2 - ix_2 y_1 - i^2 y_1 y_2}{x_1^2 - (iy_1)^2} = \frac{x_1 x_2 + ix_1 y_2 - ix_2 y_1 + y_1 y_2}{x_1^2 + y_1^2} \\ &= \frac{(x_1 x_2 + y_1 y_2) + i(x_1 y_2 - x_2 y_1)}{x_1^2 + y_1^2} = \frac{(x_1 x_2 + y_1 y_2)}{x_1^2 + y_1^2} + i \frac{(x_1 y_2 - x_2 y_1)}{x_1^2 + y_1^2} \end{aligned}$$

$$\operatorname{Re} \left(\frac{x_1 + iy_1}{x_2 + iy_2} \right)^{-1} = \frac{x_1x_2 + y_1y_2}{x_1^2 + y_1^2} = \frac{\operatorname{Re}(z_1)\operatorname{Re}(z_2) + \operatorname{Im}(z_1)\operatorname{Im}(z_2)}{|z_1|^2}$$

$$\operatorname{Im} \left(\frac{x_1 + iy_1}{x_2 + iy_2} \right)^{-1} = \frac{x_1y_2 - x_2y_1}{x_1^2 + y_1^2} = \frac{\operatorname{Re}(z_1)\operatorname{Im}(z_2) - \operatorname{Re}(z_2)\operatorname{Im}(z_1)}{|z_1|^2}$$

When $n = 2$

$$\begin{aligned} \left(\frac{x_1 + iy_1}{x_2 + iy_2} \right)^n &= \left(\frac{x_1 + iy_1}{x_2 + iy_2} \right)^2 = \frac{(x_1 + iy_1)^2}{(x_2 + iy_2)^2} = \frac{x_1^2 + (iy_1)^2 + 2ix_1y_1}{x_2^2 + (iy_2)^2 + 2ix_2y_2} \\ &= \frac{x_1^2 - y_1^2 + 2ix_1y_1}{x_2^2 - y_2^2 + 2ix_2y_2} = \frac{(x_1^2 - y_1^2) + 2ix_1y_1}{(x_2^2 - y_2^2) + 2ix_2y_2} \cdot \frac{(x_2^2 - y_2^2) - 2ix_2y_2}{(x_2^2 - y_2^2) - 2ix_2y_2} \\ &= \frac{(x_1^2 - y_1^2)(x_2^2 - y_2^2) - 2ix_2y_2(x_1^2 - y_1^2) + 2ix_1y_1(x_2^2 - y_2^2) - 4i^2(x_1y_1)(x_2y_2)}{(x_2^2 - y_2^2)^2 - (2ix_2y_2)^2} \\ &= \frac{(x_1^2 - y_1^2)(x_2^2 - y_2^2) + 2i[x_1y_1(x_2^2 - y_2^2) - x_2y_2(x_1^2 - y_1^2)] + 4(x_1y_1)(x_2y_2)}{x_2^4 + y_2^4 - 2x_2^2y_2^2 + 4x_2^2y_2^2} \\ &= \frac{[(x_1^2 - y_1^2)(x_2^2 - y_2^2) + 4(x_1y_1)(x_2y_2)] + 2i[x_1y_1(x_2^2 - y_2^2) - x_2y_2(x_1^2 - y_1^2)]}{x_2^4 + y_2^4 + 2x_2^2y_2^2} \\ &= \frac{(x_1^2 - y_1^2)(x_2^2 - y_2^2) + 4x_1x_2y_1y_2}{(x_2^2 + y_2^2)^2} + i \frac{2[x_1y_1(x_2^2 - y_2^2) - x_2y_2(x_1^2 - y_1^2)]}{(x_2^2 + y_2^2)^2} \end{aligned}$$

So,

$$\begin{aligned} \operatorname{Re} \left(\frac{x_1 + iy_1}{x_2 + iy_2} \right)^2 &= \frac{(x_1^2 - y_1^2)(x_2^2 - y_2^2) + 4x_1x_2y_1y_2}{(x_2^2 + y_2^2)^2} \\ &= \frac{[(\operatorname{Re}z_1)^2 - (\operatorname{Im}z_1)^2][(\operatorname{Re}z_2)^2 - (\operatorname{Im}z_2)^2] + 4\operatorname{Re}z_1\operatorname{Re}z_2\operatorname{Im}z_1\operatorname{Im}z_2}{|z_2|^4} \end{aligned}$$

And

$$\begin{aligned} \operatorname{Im} \left(\frac{x_1 + iy_1}{x_2 + iy_2} \right)^2 &= \frac{2[x_1y_1(x_2^2 - y_2^2) - x_2y_2(x_1^2 - y_1^2)]}{(x_2^2 + y_2^2)^2} \\ &= \frac{2[\operatorname{Re}z_1\operatorname{Im}z_1\{(\operatorname{Re}z_2)^2 - (\operatorname{Im}z_2)^2\} - \operatorname{Re}z_2\operatorname{Im}z_2\{(\operatorname{Re}z_1)^2 - (\operatorname{Im}z_1)^2\}]}{|z_2|^4} \end{aligned}$$

When $n = -2$

$$\left(\frac{x_1 + iy_1}{x_2 + iy_2} \right)^n = \left(\frac{x_1 + iy_1}{x_2 + iy_2} \right)^{-2} = \frac{(x_1 + iy_1)^{-2}}{(x_2 + iy_2)^{-2}} = \frac{(x_2 + iy_2)^2}{(x_1 + iy_1)^2}$$

Its real and imaginary parts can be found by interchanging x_1 with x_2 and y_1 with y_2 in the case when $n = 2$. So

$$\operatorname{Re} \left(\frac{x_1 + iy_1}{x_2 + iy_2} \right)^{-2} = \frac{(x_2^2 - y_2^2)(x_1^2 - y_1^2) + 4x_2x_1y_2y_1}{(x_1^2 + y_1^2)^2}$$

$$\begin{aligned}
 &= \frac{(x_1^2 - y_1^2)(x_2^2 - y_2^2) + 4x_1x_2y_1y_2}{(x_1^2 + y_1^2)^2} \\
 &= \frac{[(\operatorname{Re}z_1)^2 - (\operatorname{Im}z_1)^2][(\operatorname{Re}z_2)^2 - (\operatorname{Im}z_2)^2] + 4\operatorname{Re}z_1\operatorname{Re}z_2\operatorname{Im}z_1\operatorname{Im}z_2}{|z_1|^4} \\
 \operatorname{Im} \left(\frac{x_1 + iy_1}{x_2 + iy_2} \right)^{-2} &= \frac{2[x_2y_2(x_1^2 - y_1^2) - x_1y_1(x_2^2 - y_2^2)]}{(x_1^2 + y_1^2)^2} \\
 &= \frac{-2[x_1y_1(x_2^2 - y_2^2) - x_2y_2(x_1^2 - y_1^2)]}{(x_1^2 + y_1^2)^2} \\
 &= \frac{-2[\operatorname{Re}z_1\operatorname{Im}z_1\{(\operatorname{Re}z_2)^2 - (\operatorname{Im}z_2)^2\} - \operatorname{Re}z_2\operatorname{Im}z_2\{(\operatorname{Re}z_1)^2 - (\operatorname{Im}z_1)^2\}]}{|z_1|^4}
 \end{aligned}$$

Example: If $x_1 + iy_1 = 12 + 5i$ and $x_2 + iy_2 = 3 + 2i$ then find the real and imaginary parts of the following:

(i) $\frac{x_1 + iy_1}{x_2 + iy_2}$ (ii) $\left(\frac{x_1 + iy_1}{x_2 + iy_2}\right)^{-1}$ (iii) $\left(\frac{x_1 + iy_1}{x_2 + iy_2}\right)^2$ (iv) $\left(\frac{x_1 + iy_1}{x_2 + iy_2}\right)^{-2}$

Solution:

(i)

$$\frac{x_1 + iy_1}{x_2 + iy_2} = \frac{12 + 5i}{3 + 2i}$$

Now,

$$\operatorname{Re} \left(\frac{x_1 + iy_1}{x_2 + iy_2} \right) = \frac{(x_1x_2 + y_1y_2)}{x_2^2 + y_2^2} = \frac{(12)(3) + (5)(2)}{3^2 + 2^2} = \frac{36 + 10}{9 + 4} = \frac{46}{13}$$

And

$$\operatorname{Im} \left(\frac{x_1 + iy_1}{x_2 + iy_2} \right) = \frac{(x_2y_1 - x_1y_2)}{x_2^2 + y_2^2} = \frac{(3)(5) - (12)(2)}{3^2 + 2^2} = \frac{15 - 24}{9 + 4} = \frac{-9}{13}$$

(ii)

$$\left(\frac{x_1 + iy_1}{x_2 + iy_2}\right)^{-1} = \left(\frac{12 + 5i}{3 + 2i}\right)^{-1}$$

$$\operatorname{Re} \left(\frac{x_1 + iy_1}{x_2 + iy_2} \right)^{-1} = \frac{x_1x_2 + y_1y_2}{x_1^2 + y_1^2} = \frac{(12)(3) + (5)(2)}{12^2 + 5^2} = \frac{36 + 10}{144 + 25} = \frac{46}{169}$$

And

$$\operatorname{Im} \left(\frac{x_1 + iy_1}{x_2 + iy_2} \right)^{-1} = \frac{x_1y_2 - x_2y_1}{x_1^2 + y_1^2} = \frac{(12)(2) - (3)(5)}{12^2 + 5^2} = \frac{24 - 15}{144 + 25} = \frac{9}{169}$$

(iii)

$$\left(\frac{x_1 + iy_1}{x_2 + iy_2}\right)^2 = \left(\frac{12 + 5i}{3 + 2i}\right)^2$$

Now,

$$\begin{aligned} \operatorname{Re} \left(\frac{x_1 + iy_1}{x_2 + iy_2} \right)^2 &= \frac{(x_1^2 - y_1^2)(x_2^2 - y_2^2) + 4x_1x_2y_1y_2}{(x_2^2 + y_2^2)^2} \\ &= \frac{(12^2 - 5^2)(3^2 - 2^2) + 4(12)(3)(5)(2)}{(3^2 + 2^2)^2} \\ &= \frac{(144 - 25)(9 - 4) + 1440}{(9 + 4)^2} = \frac{(119)(5) + 1440}{13^2} = \frac{595 + 1440}{169} \\ &= \frac{2035}{169} \end{aligned}$$

And

$$\begin{aligned} \operatorname{Im} \left(\frac{x_1 + iy_1}{x_2 + iy_2} \right)^2 &= \frac{2[x_1y_1(x_2^2 - y_2^2) - x_2y_2(x_1^2 - y_1^2)]}{(x_2^2 + y_2^2)^2} \\ &= \frac{2[(12)(5)(3^2 - 2^2) - (3)(2)(12^2 - 5^2)]}{(3^2 + 2^2)^2} = \frac{2[60(9 - 4) - 6(144 - 25)]}{(9 + 4)^2} \\ &= \frac{2(300 - 714)}{13^2} = \frac{2(-414)}{169} = \frac{-828}{169} \end{aligned}$$

(iv)

$$\left(\frac{x_1 + iy_1}{x_2 + iy_2} \right)^{-2} = \left(\frac{12 + 5i}{3 + 2i} \right)^{-2}$$

Now,

$$\begin{aligned} \operatorname{Re} \left(\frac{x_1 + iy_1}{x_2 + iy_2} \right)^{-2} &= \frac{(x_1^2 - y_1^2)(x_2^2 - y_2^2) + 4x_1x_2y_1y_2}{(x_1^2 + y_1^2)^2} \\ &= \frac{(12^2 - 5^2)(3^2 - 2^2) + 4(12)(3)(5)(2)}{(12^2 + 5^2)^2} \\ &= \frac{(144 - 25)(9 - 4) + 1440}{(144 + 25)^2} = \frac{(119)(5) + 1440}{169^2} = \frac{595 + 1440}{28561} \\ &= \frac{2035}{28561} \end{aligned}$$

And

$$\begin{aligned} \operatorname{Im} \left(\frac{x_1 + iy_1}{x_2 + iy_2} \right)^{-2} &= \frac{-2[x_1y_1(x_2^2 - y_2^2) - x_2y_2(x_1^2 - y_1^2)]}{(x_1^2 + y_1^2)^2} \\ &= \frac{-2[(12)(5)(3^2 - 2^2) - (3)(2)(12^2 - 5^2)]}{(12^2 + 5^2)^2} \\ &= \frac{-2[60(9 - 4) - 6(144 - 25)]}{(144 + 25)^2} = \frac{-2(300 - 714)}{169^2} \\ &= \frac{2(-414)}{28561} = \frac{828}{169} \end{aligned}$$

Example: Write the equation $|z - 2i| = |\bar{z} + 3|$ in terms of x and y , by taking $z = x + iy$.

Solution:

Since, $z = x + iy$
 $\Rightarrow \bar{z} = x - iy$
 $\therefore |z - 2i| = |\bar{z} + 3|$
 $\Rightarrow |x + iy - 2i| = |x - iy + 3|$
 $\Rightarrow |x + i(y - 2)| = |(x + 3) - iy|$
 $\Rightarrow \sqrt{x^2 + (y - 2)^2} = \sqrt{(x + 3)^2 + (-y)^2}$
 Squaring both sides.
 $x^2 + (y - 2)^2 = (x + 3)^2 + (y)^2$
 $\Rightarrow x^2 + y^2 - 4y + 4 = x^2 + 6y + 9 + y^2$
 $\Rightarrow -4y + 4 = 6y + 9$
 $\Rightarrow 6x + 4y + 5 = 0$

Example: Write the inequation $Re(z - 3) \leq 2$ in terms of x and y , by taking $z = x + iy$.

Solution:

$Re(z - 3) \leq 2$
 $Re(x + iy - 3) \leq 2$
 $Re\{(x - 3) + iy\} \leq 2$
 $x - 3 \leq 2$
 $\Rightarrow x \leq 5$

Exercise 1.2

- Show that for any complex number.
 - $Re(iz) = -Im(z)$
 - $Im(iz) = Re(z)$
- Use the algebraic properties of complex numbers to prove that:
 $(z_1 z_2)(z_3 z_4) = (z_1 z_3)(z_2 z_4) = z_3(z_1 z_2)z_4$
- Prove that for $z \in \mathbb{C}$.
 - z is real iff $z = \bar{z}$
 - $\frac{z - \bar{z}}{z + \bar{z}} = i \left(\frac{Im z}{Re z} \right)$
 - z is either real or pure imaginary iff $(\bar{z})^2 = z^2$
- If $z_1 = 2 - 3i$ and $|z_1 z_2| = 16$ find $|z_2|$.
- If z_1 and z_2 are any two complex numbers then prove that
 $|z_1 + z_2|^2 - |z_1 - z_2|^2 = 4Re(z_1)Re(z_2)$
- Find the value of λ ; if $\left| \frac{z_1}{z_2} + \lambda \right| = \sqrt{\lambda + 2}$; where $z_1 = 3 + i$ and $z_2 = 1 + i$.
- Verify that $\sqrt{2}|z| \geq |Re(z)| + |Im(z)|$ Hint: (Start with $(|x| - |y|)^2 \geq 0$)
- Write the following equations and inequations in terms of x and y by taking $z = x + iy$.
 - $|2z - i| = 4$
 - $|z - 1| = |\bar{z} + i|$
 - $|z - 4i| + |z + 4i| = 10$
 - $\frac{1}{2}Re(i\bar{z}) = 4$
 - $Im\left(\frac{z-1}{2i}\right) = -5$
 - $-2 \leq Im(z + i) \leq 3$

9. Find real and imaginary parts of the followings:

(i) $(2 + 4i)^{-1}$ (ii) $(3 - \sqrt{-4})^{-2}$ (iii) $\left(\frac{7+2i}{3-i}\right)^{-1}$

(iv) $\left(\frac{4+2i}{2+5i}\right)^{-2}$ (v) $\left(\frac{5-4i}{5+4i}\right)^2$ (vi) $\frac{3-7i}{2+5i}$

10. For $z_1 = -3 + 2i$ and $z_2 = 1 - 3i$ verify the followings:

(i) $|z_1| = |-z_1| = |\bar{z}_1| = |-\bar{z}_1|$ (ii) $\overline{\left(\frac{z_1}{z_2}\right)} = \frac{\bar{z}_1}{\bar{z}_2}$ (iii) $\overline{z_1 z_2} = \bar{z}_1 \bar{z}_2$

(iv) $\overline{z_1 + z_2} = \bar{z}_1 + \bar{z}_2$ (v) $|z_1 z_2| = |z_1| |z_2|$ (vi) $|z_1 + z_2| \leq |z_1| + |z_2|$

1.6 Solution of Equations

Solution of an equation is the process to find the values of the variables (unknowns) involved in the equation which when substituted in the equation, the equation is satisfied i.e.; value of the left-hand side in the equation is equal to the right-hand side of the equation.

When we consider more than one equation then it is called system of equations and if we find the values of variables which satisfies all the equations under considerations simultaneously, is called the simultaneous solutions of the equations.

If z and ω are the two complex variables then an equation of the form $az + b\omega = p$ is called equation with complex variables z and ω . Here a and b cannot be zero at the same time. If a and b belong to the set of complex numbers (i.e.; they are themselves complex numbers) then the equation is called linear equation in two variables with complex coefficients.

Here we will find the solution of system of two simultaneous equations in two variables with complex coefficients.

- A system of equations is **consistent** if it has at least one solution.
- A system of equations which has no solution is called **inconsistent**.

1.6.1 Working Rule to Find the Solution by Elimination Method

Consider the two linear equations:

$$a_1 z + b_1 \omega = p_1 \quad \text{and} \quad a_2 z + b_2 \omega = p_2$$

Step 1: Multiply the equation or both equations by suitable numbers so that the coefficients of one of the variables become same.

Step 2: By adding or subtracting the equations thus obtained in **Step 1**, eliminate the term involving the variable having same coefficients.

Step 3: The equation obtained in **Step 2** will have only one variable. From here find the value of this variable.

Step 4: Substitute the value of the variable found in **Step 3** in any one of the given equations and get the value of the other variable.

Step 5: Writing the values of z and ω in the form of ordered pair (z, ω) is the solution of the system of equations.

1.6.2 Working Rule to Find the Solution by Substitution Method

Step 1: Find the value of any one of the variables in terms of the other variable from any one of the equations given above.

Step 2: Substitute the value of the variable obtained in Step 1 to the equation which is not used yet.

Step 3: Equation obtained in the Step 2 will involve only one variable. Find its value.

Step 4: Substitute the value of variable obtained in Step 3 in any one the given equations and get the value of the other variable.

Step 5: Writing the values of the both unknowns z and ω in the ordered pair (z, ω) is the solution of the system.

Example: Solve the following system of simultaneous equations:

$$2z - (1 - 3i)\omega = 1 + 2i, \quad (1 + i)z + (2 - i)\omega = 2 + i$$

Solution:

$$2z - (1 - 3i)\omega = 1 + 2i \quad (1)$$

$$(1 + i)z + (2 - i)\omega = 2 + i \quad (2)$$

Multiplying Eq. (1) by $(1 + i)$ and Eq. (2) by 2 then subtracting Eq. (2) from (1).

$$(1) \Rightarrow 2(1 + i)z - (1 + i)(1 - 3i)\omega = (1 + i)(1 + 2i)$$

$$(2) \Rightarrow 2(1 + i)z + 2(2 - i)\omega = 2(2 + i)$$

$$\underline{\hspace{10em} - (1 + i)(1 - 3i)\omega - 2(2 - i)\omega = (1 + i)(1 + 2i) - 2(2 + i) \hspace{10em}}$$

$$\Rightarrow -[(1 + i)(1 - 3i) + 2(2 - i)]\omega = (1 + i)(1 + 2i) - 2(2 + i)$$

$$\Rightarrow -(1 - 3i + i - 3i^2 + 4 - 2i)\omega = 1 + 2i + i + 2i^2 - 4 - 2i$$

$$\Rightarrow -(1 - 3i + i + 3 + 4 - 2i)\omega = 1 + 2i + i - 2 - 4 - 2i$$

$$\Rightarrow -(8 - 4i)\omega = -5 + i$$

$$\Rightarrow (-8 + 4i)\omega = -5 + i$$

$$\Rightarrow \omega = \frac{-5 + i}{-8 + 4i} = \frac{-5 + i}{-8 + 4i} \cdot \frac{-8 - 4i}{-8 - 4i} = \frac{40 + 20i - 8i - 4i^2}{(-8)^2 - (4i)^2} = \frac{40 + 12i + 4}{64 + 16}$$

$$= \frac{44 + 12i}{80} = \frac{44}{80} + i \frac{12}{80} = \frac{11}{20} + i \frac{3}{20}$$

Substituting value of ω in Eq. (1)

$$(1) \Rightarrow 2z - (1 - 3i)\left(\frac{11}{20} + i \frac{3}{20}\right) = 1 + 2i$$

$$\Rightarrow 2z - (1 - 3i)\left(\frac{11 + 3i}{20}\right) = 1 + 2i$$

Multiplying both sides of the equation with 20.

$$\Rightarrow 40z - (11 + 3i - 33i - 9i^2) = 20(1 + 2i)$$

$$\Rightarrow 40z - (11 - 30i + 9) = 20 + 40i$$

$$\Rightarrow 40z - (20 - 30i) = 20 + 40i$$

$$\Rightarrow 40z = 20 + 40i + (20 - 30i)$$

$$\Rightarrow 40z = 40 + 10i$$

$$\Rightarrow z = \frac{40}{40} + \frac{10}{40}i = 1 + \frac{1}{4}i$$

$\therefore \left(1 + \frac{1}{4}i, \frac{11}{20} + \frac{3}{20}i\right)$ is the solution of the system of equations.

Solve the system by Cramer's rule.

1.7 Complex Polynomial

If z is a complex variable, then the expression $a_0 + a_1z + a_2z^2 + \dots + a_nz^n$ is called complex polynomial of degree n if $a_n \neq 0$ and n is a non-negative integer. Here $a_0, a_1, a_2, \dots, a_n$ are constants and may be real or complex. Let us denote this polynomial by $P(z)$ i.e.;

$$P(z) = a_0 + a_1z + a_2z^2 + \dots + a_nz^n$$

When $n = 1$; then the polynomial is $a_0 + a_1z$ and is called linear polynomial. We are interested to factorize the polynomial of the two types as a product of linear factors.

- (i) $P(z) = z^2 + a^2$; where a is a real number.
- (ii) $P(z) = az^3 + bz^2 + cz + d$; where a, b, c, d are all real numbers.

1.7.1 Factorization of Polynomial of the Type $z^2 + a^2$ as a Polynomial of Linear Factor

The factorization of this type of polynomials is simple. Consider

$$z^2 + a^2 = z^2 - i^2a^2 = z^2 - (ia)^2 = (z + ia)(z - ia)$$

$(z + ia)(z - ia)$ are required linear factors of $z^2 + a^2$.

1.7.2 Factorization of Polynomial of the Type $az^3 + bz^2 + cz + d = 0$ where $a \neq 0$

To factorize this type of polynomial first we find one of its factors with the help of factor theorem and then do the synthetic division to find the depressed equation.

Recall that $z - a$ is a factor of the polynomial $P(z)$ iff $P(a) = 0$. We may say that a is a root or zero of the polynomial.

e.g.; $z - 2$ is a factor (root or zero) of the polynomial $P(z) = 2z^3 + 3z^2 + 6z - 40$; since $P(2) = 2(2)^3 + 3(2)^2 + 6(2) - 40 = 0$.

Example: Factorize the polynomial $P(z) = z^3 + 2z^2 - 5z - 6$.

Solution: Product of coefficient of z^3 and the last term is $(1)(6) = 6$.

The possible roots of the equation are the factors of 6 which are $\pm 1, \pm 2, \pm 3, \pm 6$.

Since

$$P(-1) = (-1)^3 + 2(-1)^2 - 5(-1) - 6 = 0.$$

So $z - (-1) = z + 1$ is a factor of the polynomial. To factorize it completely use the method of synthetic division.

| | | | | |
|----|---|----|----|----|
| | 1 | 2 | -5 | -6 |
| -1 | 0 | -1 | -1 | 6 |
| | 1 | 1 | -6 | 0 |

$$\therefore z^3 + 2z^2 - 5z - 6 = (z + 1)(z^2 + z - 6)$$

$$\begin{aligned}
 &= (z + 1)(z^2 + 3z - 2z - 6) \\
 &= (z + 1)[z(z + 3) - 2(z + 3)] \\
 &= (z + 1)(z + 3)(z - 2)
 \end{aligned}$$

1.7.3 Solution by Completing Square Method:

Example: Solve the equation $2z^2 - 6z - 9 = 0$ by completing square method.

Solution:

The given equation is

$$2z^2 - 6z - 9 = 0$$

Dividing both sides by 2 (coefficient of z^2)

$$z^2 - 3z - \frac{9}{2} = 0$$

$$z^2 - 3z = \frac{9}{2}$$

Adding $\left(-\frac{3}{2}\right)^2$ on both sides

$$z^2 - 3z + \left(-\frac{3}{2}\right)^2 = \frac{9}{2} + \left(-\frac{3}{2}\right)^2$$

$$\left(z - \frac{3}{2}\right)^2 = \frac{9}{2} + \frac{9}{4} = \frac{27}{4}$$

Taking square root on both sides

$$\begin{aligned}
 z - \frac{3}{2} &= \pm \frac{3\sqrt{3}}{2} \\
 \Rightarrow z &= \frac{3}{2} \pm \frac{3\sqrt{3}}{2} = \frac{3 \pm 3\sqrt{3}}{2}
 \end{aligned}$$

$$S.S = \left\{ \frac{3 \pm 3\sqrt{3}}{2} \right\}$$

Exercise 1.3

1. Factorize the following polynomials into linear functions:

- (i) $z^2 + 169$ (ii) $2z^2 + 18$ (iii) $3z^2 + 363$ (iv) $z^2 + \frac{3}{25}$
 (v) $2z^3 + 3z^2 - 10z - 15$ (vi) $z^3 - 7z + 6$ (vii) $z^3 + 2z^2 - 23z - 60$
 (viii) $2z^3 + 9z^2 - 11z - 30$ (ix) $z^2 - 7z - 8$ (x) $4z^2 - 7z - 11$

2. Solve the following equations by completing square method

- (i) $z^2 - 6z + 2 = 0$ (ii) $-\frac{1}{2}z^2 - 5z + 2 = 0$
 (iii) $4z^2 + 5z = 14$ (iv) $z^2 = 5z - 3$

3. Solve the following quadratic equations:

- (i) $\frac{1}{3}z^2 + 2z - 16 = 0$ (ii) $z^2 - \frac{1}{2}z + 17 = 0$
 (iii) $z^2 - 6z + 25 = 0$ (iv) $z^2 - 9z + 11 = 0$

4. Solve the simultaneous system of linear equations with complex coefficients:

(i) $(1 - i)z + (1 + i)\omega = 3; \quad 2z - (2 + 5i)\omega = 2 + 3i$

(ii) $2iz + (3 - 2i)\omega = 1 + i; \quad (1 - 2i)z + (3 + 2i)\omega = 5 + 6i$

(iii) $\frac{3}{i}z - (6 + 2i)\omega = 5; \quad \frac{i}{2}z + \left(\frac{3}{4} - \frac{1}{2}i\right)\omega = \left(\frac{1}{2} + 2i\right)$

(iv) $\frac{1}{1-i}z + (1 + i)\omega = 3; \quad \frac{2}{i}z - (2 - 3i)\omega = 2 + 6i$

1.8 Polar Coordinate System

Another way to locate a point in the plane is polar coordinate system consists of a fixed-point O called the pole and the horizontal line emerging from the pole is called initial line (polar axis).

For a point P in the plane if r is its distance from the pole and θ is the angle which is measured anticlockwise from the initial line to the line \overline{OP} then the ordered pair (r, θ) are the polar coordinates of the point P.

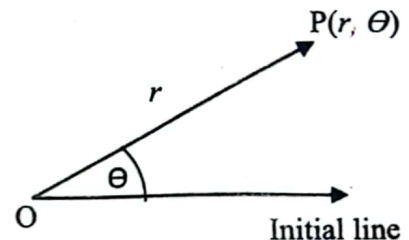

The angle θ is also called the $arg(z)$.

- For $z = 0$ the $arg(z)$ is undefined so it is understood that $z \neq 0$ whenever we use polar coordinate system.
- If a complex number $z = x + iy$ has polar coordinates (r, θ) then its conjugate is $\bar{z} = x - iy$ has polar coordinates $(r, -\theta)$.

1.9 Complex Numbers in Polar Form

1.9.1 Polar Representation of a Complex Number

Consider a complex number $z = x + iy$ in cartesian form. Draw it on the complex plane as shown in the figure.

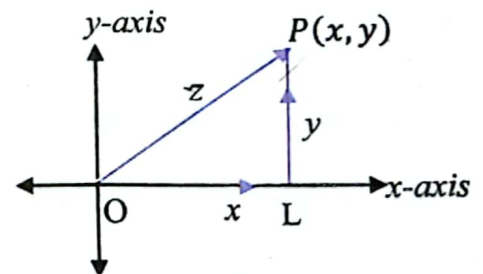

Let $r = |z|$, and θ be the angle in positive direction

which \overline{OP} makes with the initial line(x-axis).

Draw a perpendicular from P on the initial line then by Pythagoras theorem, we have

$$\begin{aligned} |OL|^2 + |LP|^2 &= |OP|^2 \\ \Rightarrow x^2 + y^2 &= |z|^2 \\ \Rightarrow x^2 + y^2 &= r^2 \end{aligned}$$

Or $r = \sqrt{x^2 + y^2}$

Also $\frac{x}{|z|} = \cos \theta \Rightarrow \frac{x}{r} = \cos \theta$

$\Rightarrow x = r \cos \theta$

And $\frac{y}{|z|} = \sin \theta \Rightarrow \frac{y}{r} = \sin \theta$

$\Rightarrow y = r \sin \theta$

Key Facts



θ is called argument of z and is written as $\theta = arg(z)$

Key Facts



$\cos \theta + i \sin \theta$ can also be written as $CiS \theta$ and $\cos \theta + i \sin \theta = e^{i\theta}$ is known as Euler's formula.

By substituting the values of x and y in $z = x + iy$

We have

$$z = r \cos \theta + ir \sin \theta$$

$$z = r(\cos \theta + i \sin \theta)$$

This form of the complex number is called polar form of a complex number.

1.9.2 Principal Argument

The symbol $\arg(z)$ actually represents a set of values, but the argument θ of a complex number that lies in the interval $-\pi < \theta \leq \pi$ is called the **principal value** of $\arg(z)$ or the **principal argument** of z . The principal argument of z is unique and is represented by the symbol $\text{Arg}(z)$, that is, $-\pi < \text{Arg}(z) \leq \pi$.

Example:

Find the modulus and principal argument of the following complex numbers.

- (i) $\sqrt{3} + i$ (ii) $-\sqrt{3} + i$ (iii) $-\sqrt{3} - i$ (iv) $\sqrt{3} - i$

Solution:

- (i) $\sqrt{3} + i$

Since the complex number $\sqrt{3} + i$ lying in the first quadrant, has the principal value $\theta = \alpha = \pi/6$.

$$\text{Modulus} = \sqrt{x^2 + y^2} = \sqrt{(\sqrt{3})^2 + 1^2} = \sqrt{3 + 1} = 2$$

$$\alpha = \tan^{-1} \left(\frac{y}{x} \right) = \frac{\pi}{6}$$

Therefore, the modulus and principal argument of $\sqrt{3} + i$ are 2 and $\pi/6$ respectively.

- (ii) $-\sqrt{3} + i$

Modulus = 2 and

Since the complex number $-\sqrt{3} + i$ lying in the second quadrant has the principal value $\theta = \pi - \alpha$. Therefore, the modulus and principal argument of $-\sqrt{3} + i$ are 2 and $\frac{5\pi}{6}$ respectively.

$$\theta = \pi - \alpha = \pi - \frac{\pi}{6} = \frac{5\pi}{6}$$

- (iii) $-\sqrt{3} - i$

$$r = 2 \text{ and } \alpha = \frac{\pi}{6}$$

Since the complex number $-\sqrt{3} - i$ lying in the third quadrant, has the principal value,

$$\theta = \pi + \alpha = -\pi + \frac{\pi}{6} = -\frac{5\pi}{6}$$

Therefore, the modulus and principal argument of $-\sqrt{3} - i$ are 2 and $-5\pi/6$ respectively.

(iv) $\sqrt{3} - i$

$r = 2$ and $\alpha = \pi/6$

Since the complex number lying in the fourth quadrant, has the principal value,

$$\theta = -\alpha = -\frac{\pi}{6}$$

Therefore, the modulus and principal argument of $\sqrt{3} - i$ are 2 and $-\pi/6$.

In all the four cases, modulus are equal, but the arguments are depending on the quadrant in which the complex number lies.

Example:

Represent the complex number (i) $-1 - i$ (ii) $1 + i\sqrt{3}$ in polar form.

Solution

(i) Let $-1 - i = r(\cos \theta + i \sin \theta)$

We have $r = \sqrt{x^2 + y^2} = \sqrt{1^2 + 1^2} = \sqrt{2}$

$$\alpha = \tan^{-1} \left| \frac{y}{x} \right| = \tan^{-1} 1 = \frac{\pi}{4}$$

Since the complex number $-1 - i$ lies in the third quadrant, it has the principal value,

$$\theta = \alpha - \pi = \frac{\pi}{4} - \pi = -\frac{3\pi}{4}$$

$$\therefore -1 - i = \sqrt{2} \left[\cos \left(-\frac{3\pi}{4} \right) + i \sin \left(-\frac{3\pi}{4} \right) \right] = \sqrt{2} \left(\cos \frac{3\pi}{4} - i \sin \frac{3\pi}{4} \right)$$

$$-1 - i = \sqrt{2} \left[\cos \left(\frac{3\pi}{4} + 2k\pi \right) - i \sin \left(\frac{3\pi}{4} + 2k\pi \right) \right]$$

(ii) $1 + i\sqrt{3}$

$$r = |z| = \sqrt{1^2 + (\sqrt{3})^2} = 2$$

$$\theta = \tan^{-1} \left(\frac{1}{\sqrt{3}} \right) = \frac{\pi}{3}$$

Hence

$$\arg(z) = \frac{\pi}{3}$$

Therefore, the polar form of $1 + i\sqrt{3}$ can be written as

$$1 + i\sqrt{3} = 2 \left(\cos \frac{\pi}{3} + i \sin \frac{\pi}{3} \right)$$

$$= 2 \left[\cos \left(\frac{\pi}{3} + 2k\pi \right) + i \sin \left(\frac{\pi}{3} + 2k\pi \right) \right]$$

Example: Find the principal arg z , when $z = \frac{-2}{1+i\sqrt{3}}$.

Solution:

$$\arg z = \arg \frac{-2}{1+i\sqrt{3}} = \arg(-2) - \arg(1+i\sqrt{3}) \quad \left(\because \arg \left(\frac{z_1}{z_2} \right) = \arg(z_1) - \arg(z_2) \right)$$

$$= \left[\pi - \tan^{-1} \left(\frac{0}{2} \right) \right] - \tan^{-1} \left(\frac{\sqrt{3}}{1} \right) = \pi - \frac{\pi}{3} = \frac{2\pi}{3}$$

This implies that one of the values of $\arg z$ is $\frac{2\pi}{3}$.

Since $\frac{2\pi}{3}$ lies between $-\pi$ and π , the principal argument $\text{Arg } z$ is $\frac{2\pi}{3}$.

1.8.2 Properties of Complex Numbers in Polar Form

Property 1:

If $z = r(\cos\theta + i\sin\theta)$, then $z^{-1} = \frac{1}{r}(\cos\theta - i\sin\theta)$.

Proof:

$$z^{-1} = \frac{1}{z} = \frac{1}{r(\cos\theta + i\sin\theta)}$$

$$= \frac{1}{r(\cos\theta + i\sin\theta)} \times \frac{(\cos\theta - i\sin\theta)}{(\cos\theta - i\sin\theta)}$$

$$= \frac{(\cos\theta - i\sin\theta)}{r(\cos^2\theta + \sin^2\theta)}$$

$$z^{-1} = \frac{1}{r}(\cos\theta - i\sin\theta)$$

Property 2:

If $z_1 = r_1(\cos\theta_1 + i\sin\theta_1)$ and $z_2 = r_2(\cos\theta_2 + i\sin\theta_2)$ are two complex numbers in polar form then their sum is given by $z_1 + z_2 = (r_1 \cos\theta_1 + r_2 \cos\theta_2) + i(r_1 \sin\theta_1 + r_2 \sin\theta_2)$

Proof:

$$\begin{aligned}z_1 + z_2 &= r_1(\cos \theta_1 + i \sin \theta_1) + r_2(\cos \theta_2 + i \sin \theta_2) \\&= r_1 \cos \theta_1 + i r_1 \sin \theta_1 + r_2 \cos \theta_2 + i r_2 \sin \theta_2 \\&= (r_1 \cos \theta_1 + r_2 \cos \theta_2) + i(r_1 \sin \theta_1 + r_2 \sin \theta_2)\end{aligned}$$

Property 3:

If $z_1 = r_1(\cos \theta_1 + i \sin \theta_1)$ and $z_2 = r_2(\cos \theta_2 + i \sin \theta_2)$ are two complex numbers in polar form then their difference is given by

$$z_1 - z_2 = (r_1 \cos \theta_1 - r_2 \cos \theta_2) + i(r_1 \sin \theta_1 - r_2 \sin \theta_2)$$

Proof:

$$\begin{aligned}z_1 - z_2 &= r_1(\cos \theta_1 + i \sin \theta_1) - r_2(\cos \theta_2 + i \sin \theta_2) \\&= r_1 \cos \theta_1 + i r_1 \sin \theta_1 - r_2 \cos \theta_2 - i r_2 \sin \theta_2 \\&= (r_1 \cos \theta_1 - r_2 \cos \theta_2) + i(r_1 \sin \theta_1 - r_2 \sin \theta_2)\end{aligned}$$

Property 4:

If $z_1 = r_1(\cos \theta_1 + i \sin \theta_1)$ and $z_2 = r_2(\cos \theta_2 + i \sin \theta_2)$ are two complex numbers in polar form then their product is given as

$$z_1 z_2 = r_1 r_2 [\cos(\theta_1 + \theta_2) + i \sin(\theta_1 + \theta_2)]$$

Proof:

$$\begin{aligned}z_1 z_2 &= r_1(\cos \theta_1 + i \sin \theta_1) r_2(\cos \theta_2 + i \sin \theta_2) \\&= r_1 r_2 [(\cos \theta_1 + i \sin \theta_1)(\cos \theta_2 + i \sin \theta_2)] \\&= r_1 r_2 [\cos \theta_1 \cos \theta_2 + i \cos \theta_1 \sin \theta_2 + i \sin \theta_1 \cos \theta_2 + i^2 \sin \theta_1 \sin \theta_2] \\z_1 z_2 &= r_1 r_2 [\cos \theta_1 \cos \theta_2 + i \cos \theta_1 \sin \theta_2 + i \sin \theta_1 \cos \theta_2 - \sin \theta_1 \sin \theta_2] \\&= r_1 r_2 [(\cos \theta_1 \cos \theta_2 - \sin \theta_1 \sin \theta_2) + i(\cos \theta_1 \sin \theta_2 + \sin \theta_1 \cos \theta_2)] \\&= r_1 r_2 [\cos(\theta_1 + \theta_2) + i \sin(\theta_1 + \theta_2)]\end{aligned}$$

Or
$$z_1 z_2 = r_1 r_2 e^{i(\theta_1 + \theta_2)}$$

Property 5:

If $z_1 = r_1(\cos \theta_1 + i \sin \theta_1)$ and $z_2 = r_2(\cos \theta_2 + i \sin \theta_2)$ are two complex numbers in polar form then their division is given as $\frac{z_1}{z_2} = \frac{r_1}{r_2} [\cos(\theta_1 - \theta_2) + i \sin(\theta_1 - \theta_2)]$

Proof:

$$\begin{aligned} \frac{z_1}{z_2} &= \frac{r_1(\cos \theta_1 + i \sin \theta_1)}{r_2(\cos \theta_2 + i \sin \theta_2)} \\ &= \frac{r_1 \left[\frac{(\cos \theta_1 + i \sin \theta_1)(\cos \theta_2 - i \sin \theta_2)}{(\cos \theta_2 + i \sin \theta_2)(\cos \theta_2 - i \sin \theta_2)} \right]}{r_2} \\ &= \frac{r_1 \left[\frac{\cos \theta_1 \cos \theta_2 - i \cos \theta_1 \sin \theta_2 + i \sin \theta_1 \cos \theta_2 - i^2 \sin \theta_1 \sin \theta_2}{(\cos \theta_2)^2 - (i \sin \theta_2)^2} \right]}{r_2} \\ &= \frac{r_1 \left[\frac{\cos \theta_1 \cos \theta_2 - i \cos \theta_1 \sin \theta_2 + i \sin \theta_1 \cos \theta_2 + \sin \theta_1 \sin \theta_2}{(\cos \theta_2)^2 - i^2(\sin \theta_2)^2} \right]}{r_2} \\ &= \frac{r_1 \left[\frac{(\cos \theta_1 \cos \theta_2 + \sin \theta_1 \sin \theta_2) + i(\sin \theta_1 \cos \theta_2 - \cos \theta_1 \sin \theta_2)}{\cos^2 \theta_2 + \sin^2 \theta_2} \right]}{r_2} \end{aligned}$$

$$\frac{z_1}{z_2} = \frac{r_1}{r_2} [\cos(\theta_1 - \theta_2) + i \sin(\theta_1 - \theta_2)]$$

Or $\frac{z_1}{z_2} = \frac{r_1}{r_2} e^{i(\theta_1 - \theta_2)}$

Example: Find the product $\frac{2}{3} \left(\cos \frac{\pi}{3} + i \sin \frac{\pi}{3} \right) \times 6 \left(\cos \frac{5\pi}{6} + i \sin \frac{5\pi}{6} \right)$ in rectangular form.

Solution:

$$\begin{aligned} \frac{2}{3} \left(\cos \frac{\pi}{3} + i \sin \frac{\pi}{3} \right) \times 6 \left(\cos \frac{5\pi}{6} + i \sin \frac{5\pi}{6} \right) &= \frac{2}{3} \times 6 \left[\cos \left(\frac{\pi}{3} + \frac{5\pi}{6} \right) + i \sin \left(\frac{\pi}{3} + \frac{5\pi}{6} \right) \right] \\ &= 4 \left[\cos \frac{7\pi}{6} + i \sin \frac{7\pi}{6} \right] = 4 \left[\cos \left(\pi + \frac{\pi}{6} \right) + i \sin \left(\pi + \frac{\pi}{6} \right) \right] \\ &= -4 \cos \frac{\pi}{6} - 4i \sin \frac{\pi}{6} = -4 \left(\frac{\sqrt{3}}{2} \right) - 4i \left(\frac{1}{2} \right) \\ &= -2\sqrt{3} - 2i \end{aligned}$$

Which is rectangular form.

Example: Find the quotient $\frac{2 \left(\cos \frac{9\pi}{4} + i \sin \frac{9\pi}{4} \right)}{4 \left[\cos \left(-\frac{3\pi}{4} \right) + i \sin \left(-\frac{3\pi}{4} \right) \right]}$ in rectangular form.

Solution:

$$\frac{2 \left(\cos \frac{9\pi}{4} + i \sin \frac{9\pi}{4} \right)}{4 \left[\cos \left(-\frac{3\pi}{4} \right) + i \sin \left(-\frac{3\pi}{4} \right) \right]} = \frac{2}{4} \left[\cos \left(\frac{9\pi}{4} - \left(-\frac{3\pi}{4} \right) \right) + i \sin \left(\frac{9\pi}{4} - \left(-\frac{3\pi}{4} \right) \right) \right]$$

$$= \frac{1}{2} \left[\cos \left(\frac{9\pi}{4} + \frac{3\pi}{4} \right) + i \sin \frac{12\pi}{4} \right] = \frac{1}{2} (\cos 3\pi + i \sin 3\pi) = -\frac{1}{2}$$

Which is in rectangular form.

Example: If $z = x + iy$ and $\arg \left(\frac{z-1}{z+1} \right) = \frac{\pi}{2}$, show that $x^2 + y^2 = 1$.

Solution:

$$\begin{aligned} \frac{z-1}{z+1} &= \frac{x+iy-1}{x+iy+1} = \frac{(x-1)+iy}{(x+1)+iy} = \frac{(x-1)+iy}{(x+1)+iy} \times \frac{(x+1)-iy}{(x+1)-iy} \\ &\Rightarrow \frac{z-1}{z+1} = \frac{(x^2-1)+y^2}{(x+1)^2+y^2} \end{aligned}$$

$$\text{Since, } \arg \left(\frac{z-1}{z+1} \right) = \frac{\pi}{2} \Rightarrow \tan^{-1} \frac{0}{\frac{(x^2-1)+y^2}{(x+1)^2+y^2}} = \frac{\pi}{2}$$

$$\frac{0}{x^2-1+y^2} = \tan \frac{\pi}{2} = \frac{1}{0} \Rightarrow x^2 + y^2 - 1 = 0$$

$$\Rightarrow x^2 + y^2 = 1$$

Example: Find the equation in Cartesian form, if $z = x + iy$ and $\arg(z-2) - \arg(z+2) = \frac{\pi}{4}$.

Solution:

$$\text{Given that } \arg(z-2) - \arg(z+2) = \frac{\pi}{4}$$

$$\Rightarrow \arg(x+iy-2) - \arg(x+iy+2) = \frac{\pi}{4}$$

$$\Rightarrow \arg((x-2)+iy) - \arg((x+2)+iy) = \frac{\pi}{4}$$

$$\Rightarrow \tan^{-1} \frac{y}{x-2} - \tan^{-1} \frac{y}{x+2} = \frac{\pi}{4}$$

$$\Rightarrow \tan \left(\tan^{-1} \frac{y}{x-2} - \tan^{-1} \frac{y}{x+2} \right) = \tan \frac{\pi}{4}$$

$$\Rightarrow \frac{\frac{y}{x-2} - \frac{y}{x+2}}{1 + \left(\frac{y}{x-2} \right) \left(\frac{y}{x+2} \right)} = 1$$

$$\Rightarrow \frac{y(x+2) - y(x-2)}{(x-2)(x+2) + y^2} = 1$$

$$\Rightarrow \frac{xy + 2y - xy + 2y}{x^2 - 4 + y^2} = 1 \quad \Rightarrow 4y = x^2 - 4 + y^2$$

Or $\Rightarrow x^2 + y^2 - 4y - 4 = 0$

1.10 Application of Complex Numbers in Real World

Complex numbers are used in many real-life situations such as cryptography, wave phenomena, pressure and velocity of the fluid and for the calculation of voltage and current in the circuits. These applications are of higher level so will be discussed in higher classes. Here we are going to use the complex numbers by giving an easy example of the simple harmonic motion. In simple harmonic motion we have to determine the position of the microscopic particle from its mean position. The equation which gives the position of the particle from mean position is

$$x = x_{max}e^{i\theta} \tag{1}$$

Where x is the displacement of the particle from mean position, x_{max} is the amplitude and $e^{i\theta} = \cos \theta + i \sin \theta$ is the complex number

Example: A micro particle is performing to and fro motion. Find its position at an angle of $\frac{\pi}{2}$, when its amplitude is 0.05mm.

Solution:

We are given $x_{max} = 0.05$
 $\theta = \frac{\pi}{2}$

Using the formula

$$x = x_{max}e^{i\theta}$$

$$x = 0.05e^{i\frac{\pi}{2}} = 0.05 \left(\cos \frac{\pi}{2} + i \sin \frac{\pi}{2} \right)$$

$$x = 0.05(0 + i) = 0.05i$$

It means particle is at the position where we cannot see it but just think about it.

The above formula can also be written as $x = x_{max}e^{i\omega t}$ where ω is the angular velocity and t is the time. Also $\omega = \frac{2\pi}{f}$ where f is the frequency of the particle.

Electrical Engineering:

The relation the flow of electricity, I , in a circuit, the resistance to flow, Z , called impedance, and the electromotive force, E , called voltage is given by the formula $E = I.Z$. Electrical engineers use j to represent the imaginary units. But for understanding we are representing the imaginary part with i .

Example: An electrical engineer is designing a circuit that is to have a current of $(6 - 8i)$ amps. If impedance is $(14 + 8i)$, find the voltage.

Solution:

Here we have $I = (6 - 8i)$

and impedance $Z = (14 + 8i),$

Using the formula

$$E = I \times Z$$

$$E = I \times Z = (6 - 8i)(14 + 8i) \\ = 148 - 64i.$$

Exercise 1.4

1. Write following complex numbers in polar form.

(i) $2 + i2\sqrt{3}$

(ii) $3 - i\sqrt{3}$

(iii) $-2 - i2$

(iv) $\frac{i-1}{\cos\frac{\pi}{3} + i\sin\frac{\pi}{3}}$

2. Write the complex numbers in rectangular form

(i) $\left(\cos\frac{\pi}{6} + i\sin\frac{\pi}{6}\right)\left(\cos\frac{\pi}{3} + i\sin\frac{\pi}{3}\right)$

(ii) $\frac{\cos\frac{\pi}{6} - i\sin\frac{\pi}{6}}{2(\cos\frac{\pi}{3} + i\sin\frac{\pi}{3})}$

3. If $(x_1 + iy_1)(x_2 + iy_2)(x_3 + iy_3) \dots (x_n + iy_n) = a + ib$, show that:

(i) $(x_1^2 + y_1^2)(x_2^2 + y_2^2)(x_3^2 + y_3^2) \dots (x_n^2 + y_n^2) = a^2 + b^2$

(ii) $\sum_{r=1}^n \tan^{-1}\left(\frac{y_r}{x_r}\right) = \tan^{-1}\left(\frac{b}{a}\right) + 2k\pi, k \in \mathbb{Z}$

4. If $\frac{1+z}{1-z} = \cos 2\theta + i \sin 2\theta$, show that $z = i \tan \theta$.

5. If $\cos \alpha + \cos \beta + \cos \gamma = \sin \alpha + \sin \beta + \sin \gamma = 0$, show that:

(i) $\cos 3\alpha + \cos 3\beta + \cos 3\gamma = 3\cos(\alpha + \beta + \gamma)$

(ii) $\sin 3\alpha + \sin 3\beta + \sin 3\gamma = 3\sin(\alpha + \beta + \gamma)$.

6. Write a given complex number in the algebraic form:

(i) $\sqrt{2}(\cos 315^\circ + i \sin 315^\circ)$

(ii) $5(\cos 210^\circ + i \sin 210^\circ)$

(iii) $2\left(\cos\frac{3\pi}{2} + i\sin\frac{3\pi}{2}\right)$

(iv) $4\left(\cos\frac{5\pi}{6} + i\sin\frac{5\pi}{6}\right)$

(v) $2\left(\cos\frac{\pi}{6} + i\sin\frac{\pi}{6}\right)$

(vi) $\cos 135^\circ + i \sin 135^\circ$

(vii) $10(\cos 50^\circ + i \sin 50^\circ)$

(viii) $\sqrt{2}\left(\cos\frac{3\pi}{4} + i\sin\frac{3\pi}{4}\right)$

(ix) $4\left(\cos\frac{2\pi}{3} + i\sin\frac{2\pi}{3}\right)$

(x) $7\sqrt{2}\left(\cos\frac{5\pi}{4} + i\sin\frac{5\pi}{4}\right)$

(xi) $10\sqrt{2}\left(\cos\frac{7\pi}{4} + i\sin\frac{7\pi}{4}\right)$

(xii) $2\left(\cos\frac{5\pi}{2} + i\sin\frac{5\pi}{2}\right)$

(xiii) $\frac{1}{\sqrt{2}}\left(\cos\frac{\pi}{4} + i\sin\frac{\pi}{4}\right)$

(xiv) $7(\cos 180^\circ + i \sin 180^\circ)$

(xv) $2e^{i\frac{\pi}{4}}$

(xvi) $3e^{i\frac{\pi}{2}}$

(xvii) $5e^{i\frac{\pi}{3}}$

7. Convert the following equations and inequations in Cartesian form:

(i) $\arg(z - 1) = -\frac{\pi}{4}$ (ii) $z\bar{z} = 4|e^{i\theta}|$ (iii) $-\frac{\pi}{3} \leq \arg(z - 4) \leq \frac{\pi}{3}$

(iv) $0 \leq \arg\left(\frac{z-4}{1+i}\right) \leq \frac{\pi}{6}$ (v) $\arg\left(\frac{1-iz}{1-z}\right) = \frac{\pi}{4}; z \neq i$

(vi) $\frac{1}{2}\arg(z - i) = \frac{\pi}{3} - \frac{1}{2}\arg(z + i)$

8. Calculate the position of a particle from mean position when amplitude is 0.004mm and angle is:

(i) $\frac{\pi}{4}$ (ii) $\frac{\pi}{3}$ (iii) $\frac{\pi}{6}$

9. When particle is at a position of $x = 2 + 3i$ from its mean position and $x_{max} = 1 + 4i$ is the position at maximum distance from mean position as it can be seen under microscope at this point.

(i) Calculate the angle at time $t = 0$ and find the position of the particle.

(ii) If $x = 2 + 3i$ and $x_{max} = 1 + 4i$. Calculate the frequency when $t = 2$.

10. Find the impedance Z for the following values:

(i) $E = (-50 + 100i)\text{volts}, I = (-6 - 2i)\text{amps}$

(ii) $E = (100 + 10i)\text{volts}, I = (-8 + 3i)\text{amps}$

I have Learnt

- Recalling complex number z and recognize its real and imaginary part.
- Knowing the condition for equality of complex number.
- Revising the basic operations on complex numbers.
- Defining conjugate and modulus of a complex number.
- Solving the simultaneous linear equations with complex coefficients.
- Factorizing the given polynomials like $z^2 + a^2$ or $z^3 - 3z^2 + z = 5$
- Solving quadratic equation of the form $pz^2 + qz + r = 0$, by completing squares, where p, q, r are real numbers and z is a complex number.
- Introducing complex numbers in polar coordinates.
- Applying the binary operations in polar form.
- Solving complex equations and inequations in polar form.
- Using the complex numbers in real world problems.

Review Exercise

1. Choose the correct option:

- (i) Every real number is also a _____ number.
(a) natural (b) integer (c) complex (d) rational
- (ii) Every complex number has _____ part(s).
(a) one (b) two (c) three (d) no
- (iii) Magnitude of a complex number z is the distance of z from _____.
(a) $(0, 0)$ (b) $(1, 0)$ (c) $(0, 1)$ (d) $(1, 1)$
- (iv) If z is a complex number then its mirror image is _____.
(a) $|z|$ (b) $1/z$ (c) $-z$ (d) \bar{z}
- (v) In complex plane imaginary part is drawn along _____.
(a) x -axis (b) y -axis (c) origin (d) xy -plane
- (vi) If $z_1 = 3 + 2i$ and $z_2 = 5 + 6i$ then
(a) $z_1 > z_2$ (b) $z_1 < z_2$ (c) $\bar{z}_1 = \bar{z}_2$ (d) $\bar{z}_1 = -\bar{z}_2$
- (vii) Diagram representing a complex number is called _____ diagram.
(a) vector (b) Venn (c) argand (d) ordered pair
- (viii) If $z = 3 + 4i$ then z^{-1} is
(a) $(\frac{1}{3}, \frac{1}{4})$ (b) $(-\frac{1}{3}, -\frac{1}{4})$ (c) $(\frac{3}{25}, \frac{-4}{25})$ (d) $(\frac{3}{25}, \frac{-4}{25})$
- (ix) The value of $(\sqrt{-25})(\sqrt{-4})$ is
(a) 10 (b) -10 (c) $10i$ (d) $-10i$
- (x) If $(\frac{1+i}{1-i})^n = 1$ then least positive value of n is
(a) 1 (b) 2 (c) 3 (d) 4

2. Find the values of the following:

- (i) $i^2 + i^4 + i^6 + \dots + i^{100}$ (ii) $|\frac{(3-2i)(1+i)}{2-3i}|$
- (iii) $|(3-2i)(4-i)|$ (iv) $(\frac{3+5i}{2-3i})^{-1}$

3. Factorize the following:

- (i) $3x^2 + 108$ (ii) $4x^2 + 40$

4. Locate the complex number $z = x + iy$ on the complex plane if $|\frac{z+2i}{z-2i}| = 1$.

5. Find z when $(z - 3i)(2 + 5i) = 3 - 4i$.

6. Evaluate $[\frac{1}{i^{10}} + (2 - i)^2 + \sqrt{-25}]^3$.

7. Solve by completing square method $2z^2 - 11z + 16 = 0$.

8. When particle is at a position of $\sqrt{2} + i\sqrt{2}$ nm from its mean position calculate its amplitude when $\theta = 45^\circ$.

UNIT
02

MATRICES AND DETERMINANTS

After studying this unit, students will be able to:

- Apply matrix operations (addition/subtraction and multiplication of (matrices) with real and complex entries.
- Evaluate determinants of 3×3 matrix by using cofactors and properties of determinants.
- Use row operations to find the inverse and the rank of a matrix.
- Explain a consistent and inconsistent system of linear equations and demonstrate through examples
- Solve a system of 3 by 3 nonhomogeneous linear equations by using matrix inversion method and Cramer's Rule.
- Solve a system of three homogeneous linear equations in three unknowns using the Gaussian elimination method.
- Apply concepts of matrices to real world problems such as (graphic design, data encryption, seismic analysis, cryptography, transformation of geometric shapes, social network analysis).

A very common use of matrices in daily life is encryption. We use them to scramble data for security purpose and to encode and decode this data. There is a key that helps encode and decode data which is generated by matrices. The screen of any electronic device, like smart phone or LED TV screen is essentially a pixel matrix. When we rotate the phone and it is in landscape form. The matrix is actually rotated using the transpose. When we touch the screen of a cell phone at some specific position; the position is calculated by matrix properties.

In mathematics we use matrices to solve the system of linear equations. Matrices are also used frequently almost in all sciences.

In 19th century the term matrix was introduced by English mathematician James Sylvester. Then after taking the idea of matrices from Sylvester, Arthur Cayley developed the algebra of matrices and published two papers in 1850s. On system of linear equations matrices was applied by Cayley's where they are still useful.

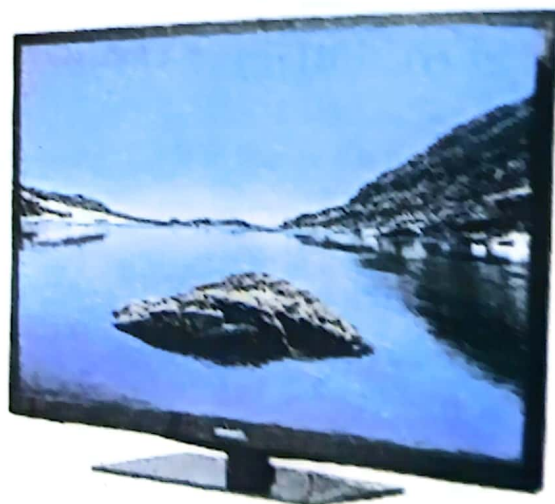

2.1 Matrices

A matrix is an array of numbers arranged in horizontal and vertical lines enclosed within square brackets. Matrices are usually denoted with capital letters.

The horizontal lines are known as rows of the matrix and vertical lines are known as columns of the matrix. e.g.;

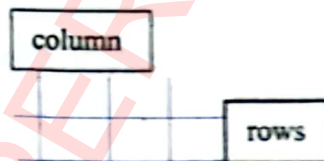

$$A = \begin{bmatrix} 2 & 1 & 3 \\ -2 & 4 & 8 \end{bmatrix}$$

Each number in the matrix is called an element or entry of the matrix. Every element in the matrix has definite position which can be specified by the number of rows first and then number of column where it exists. In the above matrix position of element '8' is determined where second row and third column meet each other. In general, an element in the i th row and the j th column is denoted by a_{ij} and the matrix A generally is written as $A = [a_{ij}]$.

2.1.1 Order of a Matrix

How many rows and columns are there in a matrix is known as order of the matrix. If a matrix A has m number of rows and n number of columns then the order of the matrix is $m \times n$ or m -by- n . We always write number of rows first then number of columns.

If we multiply m by n ; it gives us the total number of elements in the matrix. e.g.; if there are 3 rows and 2 columns in a matrix A then its order is 3×2 ; often we write $A_{3 \times 2}$. The product of 3 and 2 is 6; so, there are six elements in matrix A .

Equality of Matrices

Any two matrices are said to be equal if both have same order and same corresponding elements.

Consider matrices $A = \begin{bmatrix} 3 & 5 \\ 2 & 1 \\ 7 & 9 \end{bmatrix}$ and $B = \begin{bmatrix} 3 & 5 \\ 2 & 1 \\ 7 & 9 \end{bmatrix}$.

Here both matrices A and B are of same order 3×2 and also have same corresponding elements. Thus they are equal. We write $A = B$.

2.1.2 Types of Matrices

Row Matrix or Row Vector

If there is only one row in a matrix then the matrix is called row matrix or row vector. e.g.;

$$A = [1 \ 3 \ 6 \ 2]_{1 \times 4}; \quad B = [2 \ 5]_{1 \times 2}; \quad C = [5]_{1 \times 1}$$

$$D = [3 \ 0 \ 1 \ 9 \ 2]_{1 \times 5} \text{ are all row matrices.}$$

In general, if a row matrix A having n number of columns is

$$[a_{11} \ a_{12} \ a_{13} \ \dots \ a_{1n}]_{1 \times n}$$

Column Matrix or Column Vector

If there is only one column in a matrix then the matrix is called column matrix or column vector.

e.g. $A = \begin{bmatrix} 1 \\ 0 \\ 2 \\ 4 \end{bmatrix}_{4 \times 1}$ $B = \begin{bmatrix} 0 \\ 9 \\ 5 \end{bmatrix}_{3 \times 1}$ $C = \begin{bmatrix} 2 \\ 9 \end{bmatrix}_{2 \times 1}$ $D = [6]_{1 \times 1}$ are column matrices.

In general, a column matrix with m number of rows is

$$\begin{bmatrix} a_{11} \\ a_{21} \\ a_{31} \\ \vdots \\ a_{m1} \end{bmatrix}_{m \times 1}$$

Square Matrix

A matrix which has equal number of rows and columns is called a square matrix. i.e.; if a matrix has n number of rows and n number of columns then it is called square matrix and its order is

$n \times n$. e.g.; $\begin{bmatrix} 3 & 1 \\ -5 & 7 \end{bmatrix}_{2 \times 2}$, $\begin{bmatrix} 1 & 6 & 9 \\ 0 & 1 & -2 \\ 2 & -3 & 5 \end{bmatrix}_{3 \times 3}$, $[3]_{1 \times 1}$ are square matrices.

Rectangular Matrix

If the number of rows are not equal to the number of columns in a matrix then the matrix is called a rectangular matrix. i.e.; if a matrix has m number of rows and n number of columns and $m \neq n$ then the matrix is a rectangular matrix. e.g.;

$\begin{bmatrix} 1 & 3 & 5 \\ 2 & 0 & -1 \end{bmatrix}_{2 \times 3}$, $\begin{bmatrix} 1 & 6 \\ 2 & 9 \\ 3 & 1 \end{bmatrix}_{3 \times 2}$, $[1 \quad -2 \quad 3]_{1 \times 3}$ are rectangular matrices.

Zero or Null Matrix

If all the entries (elements) of a matrix are zero then the matrix is called null or zero matrix. A zero matrix is usually denoted by $O_{m \times n}$. e.g.;

$\begin{bmatrix} 0 & 0 \\ 0 & 0 \end{bmatrix}$, $[0 \quad 0 \quad 0 \quad 0]$, $\begin{bmatrix} 0 & 0 \\ 0 & 0 \end{bmatrix}$, $\begin{bmatrix} 0 \\ 0 \\ 0 \end{bmatrix}$, $[0]$ are zero matrices.

Diagonal of a Matrix

Consider a square matrix A of order 3×3

$$A = \begin{bmatrix} a_{11} & a_{12} & a_{13} \\ a_{21} & a_{22} & a_{23} \\ a_{31} & a_{32} & a_{33} \end{bmatrix}$$

Secondary diagonal

Main diagonal

Then elements a_{11}, a_{22}, a_{33} with same subscripts form the main diagonal or principal diagonal of the matrix and the elements a_{13}, a_{22}, a_{31} in which 1st script is increased by 1 and 2nd is decreased by 1 form the secondary diagonal of matrix. In general, for a square matrix A of order $n \times n$ primary and secondary diagonals are shown as under:

$$A = \begin{bmatrix} a_{11} & a_{12} & a_{13} & \dots & a_{1(n-1)} & a_{1n} \\ a_{21} & a_{22} & a_{23} & \dots & a_{2(n-1)} & a_{2n} \\ a_{31} & a_{32} & a_{33} & \dots & a_{3(n-1)} & a_{3n} \\ \vdots & \vdots & \vdots & \ddots & \vdots & \vdots \\ a_{n1} & a_{n2} & a_{n3} & \dots & a_{(n-1)(n-1)} & a_{nn} \end{bmatrix}$$

Secondary diagonal

Main diagonal

The elements of the main diagonal are $a_{11}, a_{22}, a_{33}, \dots, a_{nn}$ and the elements of the secondary diagonal are $a_{1n}, a_{2n-1}, \dots, a_{n1}$.

Diagonal Matrix

A square matrix in which all the elements except the main diagonal are zero and the main diagonal has at least one non zero element is called a diagonal matrix.

If $A = [a_{ij}]_{n \times n}$ is a square matrix of order n then it is called a diagonal matrix if $a_{ij} = 0$ when $i \neq j$ and $a_{ij} \neq 0$ for atleast one $i = j$ where $i = 1, 2, 3, \dots, n$ and $j = 1, 2, 3, \dots, n$.

e.g.: $\begin{bmatrix} 2 & 0 & 0 \\ 0 & 1 & 0 \\ 0 & 0 & -4 \end{bmatrix}$; $\begin{bmatrix} 6 & 0 & 0 \\ 0 & 0 & 0 \\ 0 & 0 & 2 \end{bmatrix}$; $\begin{bmatrix} 1 & 0 \\ 0 & 0 \end{bmatrix}$; $[3]$ are diagonal matrices.

Scalar Matrix

A diagonal matrix in which all the diagonal elements are same but not zero is called a scalar matrix. i.e.; if $A = [a_{ij}]_{n \times n}$ and

$\begin{cases} a_{ij} = 0 \text{ for } i \neq j \\ a_{ij} = k \text{ for } i = j \end{cases}$ where k is a non-zero scalar.

e.g.: $\begin{bmatrix} k & 0 & 0 \\ 0 & k & 0 \\ 0 & 0 & k \end{bmatrix}$ where $k \neq 0$; $\begin{bmatrix} 2 & 0 & 0 \\ 0 & 2 & 0 \\ 0 & 0 & 2 \end{bmatrix}$; $\begin{bmatrix} -1 & 0 \\ 0 & -1 \end{bmatrix}$; $\begin{bmatrix} \frac{1}{3} & 0 & 0 \\ 0 & \frac{1}{3} & 0 \\ 0 & 0 & \frac{1}{3} \end{bmatrix}$ are scalar matrices.

Identity or Unit Matrix

A scalar matrix in which all the diagonal elements are equal to 1 is known as an identity matrix.

An identity matrix is usually denoted by $I_{n \times n}$; or simply I . For an identity matrix

$$I = [a_{ij}]; \begin{cases} a_{ij} = 0 \text{ for } i \neq j \\ a_{ij} = 1 \text{ for } i = j \end{cases}$$

e.g.: $\begin{bmatrix} 1 & 0 \\ 0 & 1 \end{bmatrix}_{2 \times 2}$, $\begin{bmatrix} 1 & 0 & 0 \\ 0 & 1 & 0 \\ 0 & 0 & 1 \end{bmatrix}_{3 \times 3}$, $[1]_{1 \times 1}$ are identity matrices.

Upper Triangular Matrix

A square matrix in which all the elements lying below the main diagonal are zero; is called an upper triangular matrix. i.e.; if $A = [a_{ij}]_{n \times n}$ and $a_{ij} = 0$ where $i > j$; $\begin{pmatrix} i = 1, 2, 3, \dots, n \\ j = 1, 2, 3, \dots, n \end{pmatrix}$ then A is an upper triangular matrix.

e.g.: $\begin{bmatrix} 2 & 3 & 1 \\ 0 & 1 & 6 \\ 0 & 0 & 4 \end{bmatrix}$, $\begin{bmatrix} 1 & 0 & 2 \\ 0 & 0 & 6 \\ 0 & 0 & 0 \end{bmatrix}$, $\begin{bmatrix} 1 & 2 \\ 0 & 6 \end{bmatrix}$ are upper triangular matrices.

Lower Triangular Matrix

A square matrix in which all the elements lying above the main diagonal are zero; is called a lower triangular matrix. i.e.; if $A = [a_{ij}]_{n \times n}$ and $a_{ij} = 0$ where $i < j$; $\begin{pmatrix} i = 1, 2, 3, \dots, n \\ j = 1, 2, 3, \dots, n \end{pmatrix}$ then A is a lower triangular matrix.

e.g.; $\begin{bmatrix} 2 & 0 & 0 \\ 0 & 1 & 0 \\ 3 & 6 & 2 \end{bmatrix}$, $\begin{bmatrix} 6 & 0 & 0 \\ 0 & 0 & 0 \\ 0 & 1 & 0 \end{bmatrix}$, $\begin{bmatrix} 2 & 0 \\ 1 & 6 \end{bmatrix}$ are lower triangular matrices.

Triangular Matrix

A square matrix which is either upper triangular or lower triangular is called a triangular matrix.

Key Facts



- Sum, difference or product of upper (lower) triangular matrices is again upper (lower) matrix.
- Diagonal matrix is both upper and lower triangular matrices.

Transpose of a Matrix

If A is any matrix of order $m \times n$ then the matrix which is obtained by interchanging rows with columns of the matrix is called transpose of the matrix and is denoted by A^t . Note that the order of the A^t is $n \times m$.

e.g.; if $A = \begin{bmatrix} 2 & 1 & 6 \\ 0 & 2 & 3 \end{bmatrix}_{2 \times 3}$ then

$$A^t = \begin{bmatrix} 2 & 0 \\ 1 & 2 \\ 6 & 3 \end{bmatrix}_{3 \times 2}$$

Key Facts



- If A is square matrix, then order of A and A^t is same.
- Transpose of lower triangular matrix is an upper triangular matrix and vice versa.

Symmetric Matrix

For a square matrix A if $A = A^t$ then A is called a symmetric matrix, e.g.; if

$$A = \begin{bmatrix} 1 & 2 & 5 \\ 2 & 6 & -4 \\ 5 & -4 & 3 \end{bmatrix}, \text{ then } A^t = \begin{bmatrix} 1 & 2 & 5 \\ 2 & 6 & -4 \\ 5 & -4 & 3 \end{bmatrix}$$

Since $A = A^t$, so A is a symmetric matrix. Observe that in symmetric matrix $a_{ij} = a_{ji} \forall i \neq j$.

Skew Symmetric Matrix

A square matrix A is called skew symmetric if $A = -A^t$.

e.g.; if $A = \begin{bmatrix} 0 & 2 & -6 \\ -2 & 0 & 5 \\ 6 & -5 & 0 \end{bmatrix}$

$$\text{Then } A^t = \begin{bmatrix} 0 & -2 & 6 \\ 2 & 0 & -5 \\ -6 & 5 & 0 \end{bmatrix} = - \begin{bmatrix} 0 & 2 & -6 \\ -2 & 0 & 5 \\ 6 & -5 & 0 \end{bmatrix} = -A$$

So, A is skew symmetric.

Note that in a skew-symmetric matrix $a_{ij} = -a_{ji} \forall i \neq j$ and $a_{ij} = 0 \forall i = j$.

Exercise 2.1

1. Find the order of the following matrices.

(i) $A = \begin{bmatrix} 1 & 3 & 0 \\ 2 & 0 & 1 \end{bmatrix}$

(ii) $B = \begin{bmatrix} 1 & 2 \\ 2 & 3 \\ 3 & 4 \end{bmatrix}$

(iii) $C = \begin{bmatrix} 1 \\ 6 \\ 9 \end{bmatrix}$

(iv) $D = [2 \ 1 \ 6 \ 8]$

(v) $E = [3]$

(vi) $F = \begin{bmatrix} 3 & 6 \\ 9 & 2 \end{bmatrix}$

2. Identify the following matrices as square matrix, rectangular matrix, row matrix or column matrix.

(i) $A = \begin{bmatrix} 3 & 6 & 2 \\ 2 & 1 & 9 \end{bmatrix}$

(ii) $B = \begin{bmatrix} \frac{1}{3} & 1 \\ 2 & 6 \end{bmatrix}$

(iii) $C = \begin{bmatrix} 3 \\ 2 \\ 8 \end{bmatrix}$

(iv) $D = \begin{bmatrix} 1 & 6 & 9 \\ 2 & 0 & 1 \\ 3 & 1 & 2 \end{bmatrix}$

(v) $E = [2 \ 0 \ 1]$

(vi) $F = [16]$

3. Identify the diagonal matrix, scalar matrix, identity matrix, lower triangular matrix, upper triangular matrix.

$$A = \begin{bmatrix} 3 & 0 & 0 \\ 0 & 1 & 0 \\ 2 & 6 & 0 \end{bmatrix};$$

$$B = \begin{bmatrix} -6 & 0 & 0 \\ 0 & -6 & 0 \\ 0 & 0 & -6 \end{bmatrix};$$

$$C = \begin{bmatrix} 1 & 0 \\ 2 & 0 \end{bmatrix};$$

$$D = \begin{bmatrix} 1 & 0 & 0 \\ 0 & 1 & 0 \\ 0 & 0 & 1 \end{bmatrix};$$

$$E = \begin{bmatrix} 2 & 0 & 0 \\ 0 & 3 & 0 \\ 0 & 0 & 0 \end{bmatrix};$$

$$F = \begin{bmatrix} \sqrt{3} & 1 & 2 \\ 0 & 0 & 6 \\ 0 & 0 & 1 \end{bmatrix};$$

$$G = \begin{bmatrix} 1 & 0 & 0 \\ 0 & 0 & 0 \\ 0 & 0 & 0 \end{bmatrix};$$

$$H = \begin{bmatrix} 2 & 0 \\ 0 & 2 \end{bmatrix}$$

4. Find the transpose of the following matrices and identify which one of them are symmetric and which are skew-symmetric.

$$A = \begin{bmatrix} 2 & 0 \\ \sqrt{5} & 6 \\ 1 & 9 \end{bmatrix};$$

$$B = [1 \ 6 \ 2 \ 0];$$

$$C = \begin{bmatrix} 2 & 6 \\ 9 & 2 \end{bmatrix};$$

$$D = \begin{bmatrix} 0 & 1 & 9 \\ -1 & 0 & 5 \\ -9 & -5 & 0 \end{bmatrix};$$

$$E = \begin{bmatrix} 3 & -6 & 9 \\ -6 & 2 & 0 \\ 9 & 0 & 0 \end{bmatrix};$$

$$F = \begin{bmatrix} 9 & 0 & 1 \\ 0 & 6 & 3 \\ 0 & 0 & 1 \end{bmatrix}$$

2.2 Algebra of Matrices

2.2.1 Scalar Multiplication

If k is a non-zero scalar and $A = [a_{ij}]_{m \times n}$ is a matrix of order $m \times n$, then the product of matrix A and scalar k is denoted by the matrix kA , the matrix obtained by multiplying the scalar with each of the elements of the matrix A .

If $A = \begin{bmatrix} a_{11} & a_{12} & a_{13} & \dots & a_{1n} \\ a_{21} & a_{22} & a_{23} & \dots & a_{2n} \\ a_{31} & a_{32} & a_{33} & \dots & a_{3n} \\ \vdots & \vdots & \vdots & \ddots & \vdots \\ a_{m1} & a_{m2} & a_{m3} & \dots & a_{mn} \end{bmatrix}$, then

$$kA = k \begin{bmatrix} a_{11} & a_{12} & a_{13} & \dots & a_{1n} \\ a_{21} & a_{22} & a_{23} & \dots & a_{2n} \\ a_{31} & a_{32} & a_{33} & \dots & a_{3n} \\ \vdots & \vdots & \vdots & \ddots & \vdots \\ a_{m1} & a_{m2} & a_{m3} & \dots & a_{mn} \end{bmatrix} = \begin{bmatrix} ka_{11} & ka_{12} & ka_{13} & \dots & ka_{1n} \\ ka_{21} & ka_{22} & ka_{23} & \dots & ka_{2n} \\ ka_{31} & ka_{32} & ka_{33} & \dots & ka_{3n} \\ \vdots & \vdots & \vdots & \ddots & \vdots \\ ka_{m1} & ka_{m2} & ka_{m3} & \dots & ka_{mn} \end{bmatrix}$$

In particular if $A = \begin{bmatrix} 3 & 2 & 1 \\ 4 & -3 & 5 \end{bmatrix}$ then

$$\begin{aligned} 2A &= 2 \begin{bmatrix} 3 & 2 & 1 \\ 4 & -3 & 5 \end{bmatrix} \\ &= \begin{bmatrix} 2 \times 3 & 2 \times 2 & 2 \times 1 \\ 2 \times 4 & 2 \times -3 & 2 \times 5 \end{bmatrix} \\ &= \begin{bmatrix} 6 & 4 & 2 \\ 8 & -6 & 10 \end{bmatrix} \end{aligned}$$

Key Facts



Order of matrix A and kA is same.

Addition of Matrices

In general, we cannot add any two matrices. Only those matrices are conformable for addition which have the same order.

If $A = [a_{ij}]_{m \times n}$ and $B = [b_{ij}]_{m \times n}$ are any two matrices of same order $m \times n$ then $A + B$ is also a matrix of order $m \times n$ in which each of its elements is the sum of corresponding elements of A and B . If we assume that $A + B = C$ where $C = [c_{ij}]_{m \times n}$ then $c_{ij} = a_{ij} + b_{ij} \quad \forall i, j \in \mathbb{N}$

Subtraction of Matrices

Like addition of matrices, we can subtract two matrices which have same order.

If $A = [a_{ij}]_{m \times n}$ and $B = [b_{ij}]_{m \times n}$ are any two matrices of same order $m \times n$ then $A - B$ is also a matrix of order $m \times n$ in which each of its element is the difference of the corresponding elements of A and B . If we assume that $A - B = C$ where $C = [c_{ij}]_{m \times n}$

then $c_{ij} = a_{ij} - b_{ij} \quad \forall i, j \in \mathbb{N}$

Example: Find $A + B$ and $A - B$ where $A = \begin{bmatrix} 3 & 0 \\ 2 & 1 \\ 6 & 5 \end{bmatrix}$ and $B = \begin{bmatrix} -2 & 6 \\ 0 & 0 \\ 2 & 1 \end{bmatrix}$.

Solution:

$$A + B = \begin{bmatrix} 3 & 0 \\ 2 & 1 \\ 6 & 5 \end{bmatrix} + \begin{bmatrix} -2 & 6 \\ 0 & 0 \\ 2 & 1 \end{bmatrix} = \begin{bmatrix} 3 + (-2) & 0 + 6 \\ 2 + 0 & 1 + 0 \\ 6 + 2 & 5 + 1 \end{bmatrix} = \begin{bmatrix} 1 & 6 \\ 2 & 1 \\ 8 & 6 \end{bmatrix}$$

$$A - B = \begin{bmatrix} 3 & 0 \\ 2 & 1 \\ 6 & 5 \end{bmatrix} - \begin{bmatrix} -2 & 6 \\ 0 & 0 \\ 2 & 1 \end{bmatrix} = \begin{bmatrix} 3 - (-2) & 0 - 6 \\ 2 - 0 & 1 - 0 \\ 6 - 2 & 5 - 1 \end{bmatrix} = \begin{bmatrix} 5 & -6 \\ 2 & 1 \\ 4 & 4 \end{bmatrix}$$

Multiplication of Matrices

Two matrices A and B are conformable for multiplication if number of columns of A is equal to number of rows of B . If $A = [a_{ij}]_{m \times n}$ is a matrix of order $m \times n$ and $B = [b_{ij}]_{n \times p}$ is a matrix of order $n \times p$ then the order of AB is $[m \times p]$.

Assume that $AB = [c_{ij}]_{m \times p}$; where c_{ij} is the sum of the elements obtained by multiplying the corresponding elements of the i th row of a matrix A with corresponding elements of the j th column of matrix B . For $AB = C$, we have:

$$A = \begin{bmatrix} a_{11} & a_{12} & a_{13} & \dots & a_{1n} \\ a_{21} & a_{22} & a_{23} & \dots & a_{2n} \\ \dots & \dots & \dots & \dots & \dots \\ a_{i1} & a_{i2} & a_{i3} & \dots & a_{in} \\ \dots & \dots & \dots & \dots & \dots \\ a_{m1} & a_{m2} & a_{m3} & \dots & a_{mn} \end{bmatrix}; B = \begin{bmatrix} b_{11} & b_{12} & b_{13} & \dots & b_{1j} & \dots & b_{1p} \\ b_{21} & b_{22} & b_{23} & \dots & b_{2j} & \dots & b_{2p} \\ \dots & \dots & \dots & \dots & \dots & \dots & \dots \\ \dots & \dots & \dots & \dots & \dots & \dots & \dots \\ b_{n1} & b_{n2} & b_{n3} & \dots & b_{nj} & \dots & b_{np} \end{bmatrix}$$

↓ i th row ↓ j th column

$$C = \begin{bmatrix} c_{11} & c_{12} & c_{13} & \dots & c_{1j} & \dots & c_{1p} \\ c_{21} & c_{22} & c_{23} & \dots & c_{2j} & \dots & c_{2p} \\ \dots & \dots & \dots & \dots & \dots & \dots & \dots \\ c_{i1} & c_{i2} & \dots & \dots & c_{ij} & \dots & c_{ip} \\ \dots & \dots & \dots & \dots & \dots & \dots & \dots \\ c_{n1} & c_{n2} & c_{n3} & \dots & c_{nj} & \dots & c_{np} \end{bmatrix}$$

$c_{ij} = (a_{i1})(b_{1j}) + (a_{i2})(b_{2j}) + \dots + (a_{in})(b_{nj})$
 where $l = 1, 2, 3, \dots, m$
 $j = 1, 2, 3, \dots, p$

Example: Find the product AB for the given matrices: $A = \begin{bmatrix} 1 & 3 \\ 2 & 1 \\ 6 & 0 \end{bmatrix}_{3 \times 2}$; $B = \begin{bmatrix} 3 & 1 & 0 \\ 2 & 5 & 4 \end{bmatrix}_{2 \times 3}$

Solution:

Matrices A and B are conformable for the product of AB , since the number of columns of A and the number of rows of B is the same.

$$\begin{aligned}
 AB &= \begin{bmatrix} 1 & 3 \\ 2 & 1 \\ 6 & 0 \end{bmatrix} \begin{bmatrix} 3 & 1 & 0 \\ 2 & 5 & 4 \end{bmatrix} = \begin{bmatrix} (1)(3) + (3)(2) & (1)(1) + (3)(5) & (1)(0) + (3)(4) \\ (2)(3) + (1)(2) & (2)(1) + (1)(5) & (2)(0) + (1)(4) \\ (6)(3) + (0)(2) & (6)(1) + (0)(5) & (6)(0) + (0)(4) \end{bmatrix} \\
 &= \begin{bmatrix} 3 + 6 & 1 + 15 & 0 + 12 \\ 6 + 3 & 2 + 5 & 0 + 4 \\ 18 + 0 & 6 + 0 & 0 + 0 \end{bmatrix} \\
 &= \begin{bmatrix} 9 & 16 & 12 \\ 9 & 7 & 4 \\ 18 & 6 & 0 \end{bmatrix}
 \end{aligned}$$

Key Facts



If two matrices A and B are conformable for the product AB , then it is not necessary that they are conformable for the product BA .

Note that order of $AB = 3 \times \boxed{2 \ 2} \times 3 = 3 \times 3$

Example: Find the product AB for the given matrices.

$$A = \begin{bmatrix} 2i & 1 \\ -i & 3i \end{bmatrix}; \quad B = \begin{bmatrix} 3 & -i & i \\ 2i & 0 & -2i \end{bmatrix}$$

Solution:

The number of columns of A and the number of rows of B is same. So they are conformable for the product AB . Now

$$\begin{aligned} AB &= \begin{bmatrix} 2i & 1 \\ -i & 3i \end{bmatrix} \begin{bmatrix} 3 & -i & i \\ 2i & 0 & -2i \end{bmatrix} \\ &= \begin{bmatrix} (2i)(3) + 1(2i) & (2i)(-i) + (1)(0) & (2i)(i) + (1)(-2i) \\ (-i)(3) + (3i)(2i) & (-i)(-i) + (3i)(0) & (-i)(i) + (3i)(-2i) \end{bmatrix} \\ &= \begin{bmatrix} 6i + 2i & -2i^2 + 0 & 2i^2 - 2i \\ -3i + 6i^2 & i^2 + 0 & -i^2 - 6i^2 \end{bmatrix} \\ &= \begin{bmatrix} 8i & -2(-1) & 2(-1) - 2i \\ -3i + 6(-1) & -1 & -(-1) - 6(-1) \end{bmatrix} \\ &= \begin{bmatrix} 8i & 2 & -2 - 2i \\ -3i - 6 & -1 & 7 \end{bmatrix} \end{aligned}$$

Order of $AB = 2 \times \boxed{2 \ 2} \times 3 = 2 \times 3$

2.2.2 Commutative Property of Matrices w. r. t. Addition

Any two matrices which are conformable for addition holds commutative property w. r. t. addition. Consider the two matrices $A = [a_{ij}]_{2 \times 3}$ and $B = [b_{ij}]_{2 \times 3}$; so,

$$\begin{aligned} A &= \begin{bmatrix} a_{11} & a_{12} & a_{13} \\ a_{21} & a_{22} & a_{23} \end{bmatrix} \text{ and } B = \begin{bmatrix} b_{11} & b_{12} & b_{13} \\ b_{21} & b_{22} & b_{23} \end{bmatrix} \\ A + B &= \begin{bmatrix} a_{11} + b_{11} & a_{12} + b_{12} & a_{13} + b_{13} \\ a_{21} + b_{21} & a_{22} + b_{22} & a_{23} + b_{23} \end{bmatrix} \\ &= \begin{bmatrix} b_{11} + a_{11} & b_{12} + a_{12} & b_{13} + a_{13} \\ b_{21} + a_{21} & b_{22} + a_{22} & b_{23} + a_{23} \end{bmatrix} \\ &= \begin{bmatrix} b_{11} & b_{12} & b_{13} \\ b_{21} & b_{22} & b_{23} \end{bmatrix} + \begin{bmatrix} a_{11} & a_{12} & a_{13} \\ a_{21} & a_{22} & a_{23} \end{bmatrix} = B + A \end{aligned}$$

Example: Verify the commutative property of addition for the given matrices:

$$A = \begin{bmatrix} 3 & 1 & 6 \\ 2 & 1 & 3 \\ 0 & 2 & 1 \end{bmatrix} \text{ and } B = \begin{bmatrix} 0 & -1 & 3 \\ 1 & 2 & 4 \\ -7 & 3 & 1 \end{bmatrix}$$

Solution:

$$\begin{aligned} A + B &= \begin{bmatrix} 3 & 1 & 6 \\ 2 & 1 & 3 \\ 0 & 2 & 1 \end{bmatrix} + \begin{bmatrix} 0 & -1 & 3 \\ 1 & 2 & 4 \\ -7 & 3 & 1 \end{bmatrix} = \begin{bmatrix} 3+0 & 1+(-1) & 6+3 \\ 2+1 & 1+2 & 3+4 \\ 0+(-7) & 2+3 & 1+1 \end{bmatrix} \\ &= \begin{bmatrix} 3 & 0 & 9 \\ 3 & 3 & 7 \\ -7 & 5 & 2 \end{bmatrix} \quad (1) \end{aligned}$$

And

$$\begin{aligned}
 B + A &= \begin{bmatrix} 0 & -1 & 3 \\ 1 & 2 & 4 \\ -7 & 3 & 1 \end{bmatrix} + \begin{bmatrix} 3 & 1 & 6 \\ 2 & 1 & 3 \\ 0 & 2 & 1 \end{bmatrix} = \begin{bmatrix} 0+3 & (-1)+1 & 3+6 \\ 1+2 & 2+1 & 4+3 \\ (-7)+0 & 3+2 & 1+1 \end{bmatrix} \\
 &= \begin{bmatrix} 3 & 0 & 9 \\ 3 & 3 & 7 \\ -7 & 5 & 2 \end{bmatrix} \quad (2)
 \end{aligned}$$

From (1) and (2) we have $A + B = B + A$, i.e.; commutative property holds w. r. t addition.

Commutative Property of Matrices w. r. t. Multiplication

In general, the commutative property w. r. t. multiplication for matrices do not hold. i.e.; $AB \neq BA$.

Examples: For the matrices $A = \begin{bmatrix} 1 & 2 & 1 \\ 3 & 1 & 6 \end{bmatrix}$; $B = \begin{bmatrix} 0 & 1 \\ 2 & 3 \\ 1 & 4 \end{bmatrix}$; show that $AB \neq BA$.

Solution:

$$\begin{aligned}
 AB &= \begin{bmatrix} 1 & 2 & 1 \\ 3 & 1 & 6 \end{bmatrix} \begin{bmatrix} 0 & 1 \\ 2 & 3 \\ 1 & 4 \end{bmatrix} \\
 &= \begin{bmatrix} (1)(0) + (2)(2) + (1)(1) & (1)(1) + (2)(3) + (1)(4) \\ (3)(0) + (1)(2) + (6)(1) & (3)(1) + (1)(3) + (6)(4) \end{bmatrix} \\
 &= \begin{bmatrix} 0 + 4 + 1 & 1 + 6 + 4 \\ 0 + 2 + 6 & 3 + 3 + 24 \end{bmatrix} = \begin{bmatrix} 5 & 11 \\ 8 & 30 \end{bmatrix} \\
 BA &= \begin{bmatrix} 0 & 1 \\ 2 & 3 \\ 1 & 4 \end{bmatrix} \begin{bmatrix} 1 & 2 & 1 \\ 3 & 1 & 6 \end{bmatrix} \\
 &= \begin{bmatrix} (0)(1) + (1)(3) & (0)(2) + (1)(1) & (0)(1) + (1)(6) \\ (2)(1) + (3)(3) & (2)(2) + (3)(1) & (2)(1) + (3)(6) \\ (1)(1) + (4)(3) & (1)(2) + (4)(1) & (1)(1) + (4)(6) \end{bmatrix} \\
 &= \begin{bmatrix} 0 + 3 & 0 + 1 & 0 + 6 \\ 2 + 9 & 4 + 3 & 2 + 18 \\ 1 + 12 & 2 + 4 & 1 + 24 \end{bmatrix} = \begin{bmatrix} 3 & 1 & 6 \\ 11 & 7 & 20 \\ 13 & 6 & 25 \end{bmatrix}
 \end{aligned}$$

Clearly $AB \neq BA$.

2.2.3 Verification of $(AB)^t = B^t A^t$

Consider the two matrices A and B which are conformable for the product AB .

$$A = \begin{bmatrix} 1 & 2 \\ 5 & 6 \\ 2 & 1 \end{bmatrix}_{3 \times 2}; \quad B = \begin{bmatrix} 0 & 1 & 6 \\ 2 & 1 & 0 \end{bmatrix}_{2 \times 3} \text{ then}$$

$$\begin{aligned}
 AB &= \begin{bmatrix} 1 & 2 \\ 5 & 6 \\ 2 & 1 \end{bmatrix} \begin{bmatrix} 0 & 1 & 6 \\ 2 & 1 & 0 \end{bmatrix} = \begin{bmatrix} (1)(0) + (2)(2) & (1)(1) + (2)(1) & (1)(6) + (2)(0) \\ (5)(0) + (6)(2) & (5)(1) + (6)(1) & (5)(6) + (6)(0) \\ (2)(0) + (1)(2) & (2)(1) + (1)(1) & (2)(6) + (1)(0) \end{bmatrix} \\
 &= \begin{bmatrix} 0 + 4 & 1 + 2 & 6 + 0 \\ 0 + 12 & 5 + 6 & 30 + 0 \\ 0 + 2 & 2 + 1 & 12 + 0 \end{bmatrix} = \begin{bmatrix} 4 & 3 & 6 \\ 12 & 11 & 30 \\ 2 & 3 & 12 \end{bmatrix}
 \end{aligned}$$

$$\Rightarrow (AB)^t = \begin{bmatrix} 4 & 3 & 6 \\ 12 & 11 & 30 \\ 2 & 3 & 12 \end{bmatrix}^t = \begin{bmatrix} 4 & 12 & 2 \\ 3 & 11 & 3 \\ 6 & 30 & 12 \end{bmatrix} \quad (1)$$

Now

$$A^t = \begin{bmatrix} 1 & 5 & 2 \\ 2 & 6 & 1 \end{bmatrix} \text{ and } B^t = \begin{bmatrix} 0 & 2 \\ 1 & 1 \\ 6 & 0 \end{bmatrix}$$

$$B^t A^t = \begin{bmatrix} 0 & 2 \\ 1 & 1 \\ 6 & 0 \end{bmatrix} \begin{bmatrix} 1 & 5 & 2 \\ 2 & 6 & 1 \end{bmatrix} = \begin{bmatrix} (0)(1) + (2)(2) & (0)(5) + (2)(6) & (0)(2) + (2)(1) \\ (1)(1) + (1)(2) & (1)(5) + (1)(6) & (1)(2) + (1)(1) \\ (6)(1) + (0)(2) & (6)(5) + (0)(6) & (6)(2) + (0)(1) \end{bmatrix}$$

$$= \begin{bmatrix} 0+4 & 0+12 & 0+2 \\ 1+2 & 5+6 & 2+1 \\ 6+0 & 30+0 & 12+0 \end{bmatrix} = \begin{bmatrix} 4 & 12 & 2 \\ 3 & 11 & 3 \\ 6 & 30 & 12 \end{bmatrix} \quad (2)$$

From equation (1) and (2), we have $(AB)^t = B^t A^t$.

Example: Show that for the two matrices A and B which are conformable for addition:

$$(A + B)^t = A^t + B^t$$

Solution:

Consider any two matrices A and B of the same order.

$$A = \begin{bmatrix} a & b \\ c & d \\ e & f \end{bmatrix}; \quad B = \begin{bmatrix} 1 & 2 \\ 3 & 5 \\ 2 & 6 \end{bmatrix} \text{ then}$$

$$A + B = \begin{bmatrix} a & b \\ c & d \\ e & f \end{bmatrix} + \begin{bmatrix} 1 & 2 \\ 3 & 5 \\ 2 & 6 \end{bmatrix} = \begin{bmatrix} a+1 & b+2 \\ c+3 & d+5 \\ e+2 & f+6 \end{bmatrix}$$

$$\Rightarrow (A + B)^t = \begin{bmatrix} a+1 & b+2 \\ c+3 & d+5 \\ e+2 & f+6 \end{bmatrix}^t = \begin{bmatrix} a+1 & c+3 & e+2 \\ b+2 & d+5 & f+6 \end{bmatrix} \quad (1)$$

Now $A^t = \begin{bmatrix} a & c & e \\ b & d & f \end{bmatrix}$ and $B^t = \begin{bmatrix} 1 & 3 & 2 \\ 2 & 5 & 6 \end{bmatrix}$

$$A^t + B^t = \begin{bmatrix} a & c & e \\ b & d & f \end{bmatrix} + \begin{bmatrix} 1 & 3 & 2 \\ 2 & 5 & 6 \end{bmatrix}$$

$$= \begin{bmatrix} a+1 & c+3 & e+2 \\ b+2 & d+5 & f+6 \end{bmatrix} \quad (2)$$

From (1) and (2) we have,

$$(A + B)^t = A^t + B^t$$

Example: Any square matrix can be written as the sum of two square matrices such that one of them is symmetric and the other is skew-symmetric.

Solution:

Consider any square matrix A . Let we can write it as sum of two square matrices P and Q where P is symmetric and Q is skew-symmetric. i.e.;

$$A = P + Q; P^t = P \text{ \& } Q^t = -Q \quad (1)$$

$$\Rightarrow A^t = (P + Q)^t = P^t + Q^t = P + (-Q)$$

$$\Rightarrow A^t = P - Q \quad (2)$$

Key Facts

For any two matrices A and B which are conformable for addition

$(A + B)^t = A^t + B^t$. In general

$(A_1 + A_2 + \dots + A_n)^t$

$= A_1^t + A_2^t + \dots + A_n^t$

Adding equation (1) and equation (2), we get:

$$A + A^t = 2P \Rightarrow P = \frac{1}{2}(A + A^t)$$

Now subtracting equation (2) from equation (1), we have:

$$A - A^t = 2Q \Rightarrow Q = \frac{1}{2}(A - A^t)$$

Observe that

$$P^t = \left[\frac{1}{2}(A + A^t) \right]^t = \frac{1}{2}(A^t + (A^t)^t) = \frac{1}{2}(A^t + A) = \frac{1}{2}(A + A^t) = P$$

So, P is symmetric.

$$Q^t = \left[\frac{1}{2}(A - A^t) \right]^t = \frac{1}{2}(A^t - (A^t)^t) = \frac{1}{2}(A^t - A) = -\frac{1}{2}(A - A^t) = -Q$$

So, Q is skew-symmetric.

Example: Write the matrix $A = \begin{bmatrix} 3 & 1 & 5 \\ 2 & 6 & 0 \\ -1 & 2 & 1 \end{bmatrix}$ as a sum of two matrices where one is symmetric and the other is skew-symmetric.

Solution:

Let $A = P + Q$ where P is symmetric and Q is skew-symmetric.

$$\text{So } P = \frac{1}{2}(A + A^t) = \frac{1}{2} \left(\begin{bmatrix} 3 & 1 & 5 \\ 2 & 6 & 0 \\ -1 & 2 & 1 \end{bmatrix} + \begin{bmatrix} 3 & 2 & -1 \\ 1 & 6 & 2 \\ 5 & 0 & 1 \end{bmatrix} \right) = \frac{1}{2} \begin{bmatrix} 6 & 3 & 4 \\ 3 & 12 & 2 \\ 4 & 2 & 2 \end{bmatrix} = \begin{bmatrix} 3 & \frac{3}{2} & 2 \\ \frac{3}{2} & 6 & 1 \\ 2 & 1 & 1 \end{bmatrix}$$

And

$$Q = \frac{1}{2}(A - A^t) = \frac{1}{2} \left(\begin{bmatrix} 3 & 1 & 5 \\ 2 & 6 & 0 \\ -1 & 2 & 1 \end{bmatrix} - \begin{bmatrix} 3 & 2 & -1 \\ 1 & 6 & 2 \\ 5 & 0 & 1 \end{bmatrix} \right) = \frac{1}{2} \begin{bmatrix} 0 & -1 & 6 \\ 1 & 0 & -2 \\ -6 & 2 & 0 \end{bmatrix}$$
$$= \begin{bmatrix} 0 & -\frac{1}{2} & 3 \\ \frac{1}{2} & 0 & -1 \\ -3 & 1 & 0 \end{bmatrix}$$

Thus $A = P + Q$

$$\Rightarrow \begin{bmatrix} 3 & 1 & 5 \\ 2 & 6 & 0 \\ -1 & 2 & 1 \end{bmatrix} = \begin{bmatrix} 3 & \frac{3}{2} & 2 \\ \frac{3}{2} & 6 & 1 \\ 2 & 1 & 1 \end{bmatrix} + \begin{bmatrix} 0 & -\frac{1}{2} & 3 \\ \frac{1}{2} & 0 & -1 \\ -3 & 1 & 0 \end{bmatrix}$$

Exercise 2.2

- Construct a matrix $A = [a_{ij}]$ of order 2×2 for which:
 - $a_{ij} = \frac{i+3j}{2}$
 - $a_{ij} = \frac{i \times j}{2}$
 - $a_{ij} = \frac{i}{j}$
 - $a_{ij} = \frac{2i-3j}{3}$
- Construct a matrix $B = [a_{ij}]$ of order 3×3 for which:
 - $b_{ij} = \frac{i^2-j}{3}$
 - $b_{ij} = \frac{i^2-j^2}{2i}$
 - $b_{ij} = \frac{2}{2i+j}$
 - $b_{ij} = \frac{i^2+j^2}{i+j}$
- If $A = \begin{bmatrix} 3 & -1 & 2 \\ 0 & 6 & 1 \\ -1 & 0 & -3 \end{bmatrix}$ and $B = \begin{bmatrix} 2 & 1 & 7 \\ 0 & 2 & -1 \\ -3 & 4 & 2 \end{bmatrix}$ then find a matrix C such that:
 $A + B + C = O$
- Find $A \begin{bmatrix} 2 & 1 \\ 3 & 2 \end{bmatrix} A \begin{bmatrix} 1 & 3 \\ 2 & 4 \end{bmatrix} = \begin{bmatrix} 1 & 0 \\ 0 & 1 \end{bmatrix}$
 - Find $X \begin{bmatrix} 3 & 2 \\ 0 & 1 \\ 2 & 0 \end{bmatrix} X = \begin{bmatrix} 7/2 & 11 & 2 \\ 2 & 4 & 1 \\ 1 & 2 & 0 \end{bmatrix}$
 - If $A = [3 \ 7]$ and $B = [2 \ 14]$ then find a non-zero matrix C such that $AC = BC$.
 - $\begin{bmatrix} xy & 4 \\ 0 & x+y \end{bmatrix} = \begin{bmatrix} 8 & z \\ t & 6 \end{bmatrix}$ then find the values of z, t and $x^2 + y^2$.
 - If $A = \begin{bmatrix} 3 & 4 \\ 7 & 6 \end{bmatrix}$ and $I = \begin{bmatrix} 1 & 0 \\ 0 & 1 \end{bmatrix}$ then find α and β so that $A^2 + \alpha I = \beta A$.
 - Find the values of x if $\begin{bmatrix} x & -4 & 2 \end{bmatrix} \begin{bmatrix} 1 & 0 & 3 \\ 0 & 1 & 0 \\ 2 & 0 & 4 \end{bmatrix} \begin{bmatrix} x \\ 1 \\ -1 \end{bmatrix} = 0$.
- If $X = \begin{bmatrix} 1 & 2 & 2 \\ 2 & 1 & 2 \\ 2 & 2 & 1 \end{bmatrix}$ then prove that $X^2 - 4X - 5I = 0$.
- If $A = \begin{bmatrix} 2 & 1 \\ 3 & -3 \end{bmatrix}$ then find α and β such that, $A^2 + \alpha I = \beta A$.
- If $A = \begin{bmatrix} x & 0 \\ y & 1 \end{bmatrix}$ then
 - Prove that for all positive integers n , $A^n = \begin{bmatrix} x^n & 0 \\ \frac{y(x^n-1)}{x-1} & 1 \end{bmatrix}$.
 - If $A = \begin{bmatrix} 3 & -4 \\ 1 & -1 \end{bmatrix}$ then prove that for all positive integers n ,

$$A^n = \begin{bmatrix} 1+2n & -4n \\ n & 1-2n \end{bmatrix}$$
- Consider any two particular matrices A and B of your choice of order 2×3 and 3×2 respectively and show that $(AB)^t = B^t A^t$.
- Consider any two particular matrices A and B of your choice of order 3×3 and show that $(A+B)^t = A^t + B^t$.
- If A and B are two matrices such that $AB = B$ and $BA = A$. Find $A^2 + B^2$.
- If $A = [a_{ij}]$ is a matrix of order 3×3 and $a_{ij} = i^2 - j^2$. Check whether A is symmetric or skew-symmetric.

12. For any square matrix A ; prove that $(A^n)^t = (A^t)^n$.

13. Find the matrices X and Y such that $2X - Y = \begin{bmatrix} 1 & 6 & -3 \\ 2 & 1 & 7 \end{bmatrix}$ and $X + 3Y = \begin{bmatrix} 4 & 3 & 2 \\ 1 & -3 & 0 \end{bmatrix}$.

2.3 Determinants

Not all but every square matrix is associated with some number (real or complex). This number is called the determinant of the matrix.

If A is any square matrix then its determinant is denoted by $\det(A)$ or $|A|$.

Corresponding to the square matrix A of order n ,

$$A = \begin{bmatrix} a_{11} & a_{12} & \dots & a_{1n} \\ a_{21} & a_{22} & \dots & a_{2n} \\ \vdots & \vdots & \ddots & \vdots \\ a_{n1} & a_{n2} & \dots & a_{nn} \end{bmatrix}$$

The determinant of A is

$$|A| = \begin{vmatrix} a_{11} & a_{12} & \dots & a_{1n} \\ a_{21} & a_{22} & \dots & a_{2n} \\ \vdots & \vdots & \ddots & \vdots \\ a_{n1} & a_{n2} & \dots & a_{nn} \end{vmatrix}$$



More than one square matrix can have same value of determinant.

Key Facts

For our convenience we consider the determinants of the square matrices of order up to 3×3 .

2.3.1 Determinant of Matrix of Order 2×2

Consider a matrix $A = \begin{bmatrix} a_{11} & a_{12} \\ a_{21} & a_{22} \end{bmatrix}$; then

$$|A| = \begin{vmatrix} a_{11} & a_{12} \\ a_{21} & a_{22} \end{vmatrix} = a_{11}a_{22} - a_{21}a_{12}$$

Determinant of Matrix of Order 3×3

Consider a matrix A of order 3×3 i.e.; $A = \begin{bmatrix} a_{11} & a_{12} & a_{13} \\ a_{21} & a_{22} & a_{23} \\ a_{31} & a_{32} & a_{33} \end{bmatrix}$.

The associated determinant is $|A| = \begin{vmatrix} a_{11} & a_{12} & a_{13} \\ a_{21} & a_{22} & a_{23} \\ a_{31} & a_{32} & a_{33} \end{vmatrix}$

To find the value of this determinant; we express the above determinant into the sum or difference of determinants of order 2. This process of finding the value of the determinant is called expansion of the determinant.

We can expand a determinant from any row or any column. Since in a determinant of order 3; there are three rows namely R_1, R_2, R_3 and three columns C_1, C_2, C_3 , so we can expand the determinant in six different ways; but the value of determinant will remain the same in each case.

If we expand the above given determinant from 1st row i.e.; from R_1 then

$$\begin{aligned} |A| &= a_{11} \begin{vmatrix} a_{22} & a_{23} \\ a_{32} & a_{33} \end{vmatrix} - a_{12} \begin{vmatrix} a_{21} & a_{23} \\ a_{31} & a_{33} \end{vmatrix} + a_{13} \begin{vmatrix} a_{21} & a_{22} \\ a_{31} & a_{32} \end{vmatrix} \\ &= a_{11}(a_{22}a_{33} - a_{23}a_{32}) - a_{12}(a_{21}a_{33} - a_{23}a_{31}) + a_{13}(a_{21}a_{32} - a_{22}a_{31}) \end{aligned}$$

This can be generalized for determinants of the square matrices of higher order.

Minor of an Element of a Square Matrix

Let we have any square matrix A of order n , i.e.; $A = [a_{ij}]_{n \times n}$; then the minor of the element a_{ij} of matrix is a determinant of the matrix of order $(n - 1) \times (n - 1)$ obtained by neglecting the i th row and j th column of the matrix A . Minor of a_{ij} is denoted by M_{ij} . For example; consider a matrix A of order 3×3 .

$$A = \begin{bmatrix} a_{11} & a_{12} & a_{13} \\ a_{21} & a_{22} & a_{23} \\ a_{31} & a_{32} & a_{33} \end{bmatrix}$$

The minor of the element a_{21} is M_{21} where $M_{21} = \begin{vmatrix} a_{12} & a_{13} \\ a_{32} & a_{33} \end{vmatrix}$ is the determinant obtained by neglecting 2nd row and 1st column of the matrix A . Likewise we can find all the minors of elements of the matrix A .

Cofactor of an Element of a Square Matrix

For any square matrix A of order $n \times n$, the cofactor of an element a_{ij} of matrix A is denoted by A_{ij} and is defined as $A_{ij} = (-1)^{i+j} M_{ij}$ e.g.; If

$$A = \begin{bmatrix} a_{11} & a_{12} & a_{13} \\ a_{21} & a_{22} & a_{23} \\ a_{31} & a_{32} & a_{33} \end{bmatrix}$$

Then cofactor of the element a_{21} is:

$$\begin{aligned} A_{21} &= (-1)^{2+1} M_{21} = (-1)^3 \begin{vmatrix} a_{12} & a_{13} \\ a_{32} & a_{33} \end{vmatrix} = (-1)(a_{12}a_{33} - a_{13}a_{32}) = -a_{12}a_{33} + a_{13}a_{32} \\ &= a_{13}a_{32} - a_{12}a_{33} \end{aligned}$$

Example: If $A = \begin{bmatrix} 1 & 3 & 0 \\ -1 & 2 & 6 \\ 3 & 0 & -4 \end{bmatrix}$ then find M_{12} , M_{23} and A_{12} and A_{23} .

Solution:

$$M_{12} = \begin{vmatrix} -1 & 6 \\ 3 & -4 \end{vmatrix} = (-1)(-4) - (3)(6) = 4 - 18 = -14$$

$$M_{23} = \begin{vmatrix} 1 & 3 \\ 3 & 0 \end{vmatrix} = (1)(0) - (3)(3) = 0 - 9 = -9$$

$$A_{12} = (-1)^{1+2} M_{12} = (-1)^3 (-14) = (-1)(-14) = 14$$

$$A_{23} = (-1)^{2+3} M_{23} = (-1)(-9) = 9$$

2.3.2 Evaluation of the Determinant of a Square Matrix Using Cofactors

Consider a square matrix A of order 3×3 .

$$A = \begin{bmatrix} a_{11} & a_{12} & a_{13} \\ a_{21} & a_{22} & a_{23} \\ a_{31} & a_{32} & a_{33} \end{bmatrix}$$

Then $|A| = \begin{vmatrix} a_{11} & a_{12} & a_{13} \\ a_{21} & a_{22} & a_{23} \\ a_{31} & a_{32} & a_{33} \end{vmatrix}$

If we expand it from first row then:

$$\begin{aligned}
 |A| &= a_{11} \begin{vmatrix} a_{22} & a_{23} \\ a_{32} & a_{33} \end{vmatrix} - a_{12} \begin{vmatrix} a_{21} & a_{23} \\ a_{31} & a_{33} \end{vmatrix} + a_{13} \begin{vmatrix} a_{21} & a_{22} \\ a_{31} & a_{32} \end{vmatrix} \\
 &= a_{11}M_{11} - a_{12}M_{12} + a_{13}M_{13} \\
 &= a_{11}(-1)^{1+1}M_{11} + a_{12}(-1)^{1+2}M_{12} + a_{13}(-1)^{1+3}M_{13} \\
 &= a_{11}A_{11} + a_{12}A_{12} + a_{13}A_{13}
 \end{aligned}$$

If we expand the determinant from first column then:

$$\begin{aligned}
 |A| &= a_{11} \begin{vmatrix} a_{22} & a_{23} \\ a_{32} & a_{33} \end{vmatrix} - a_{21} \begin{vmatrix} a_{12} & a_{13} \\ a_{32} & a_{33} \end{vmatrix} + a_{31} \begin{vmatrix} a_{12} & a_{13} \\ a_{22} & a_{23} \end{vmatrix} \\
 &= a_{11}M_{11} - a_{21}M_{21} + a_{31}M_{31} \\
 &= a_{11}(-1)^{1+1}M_{11} + a_{21}(-1)^{2+1}M_{21} + a_{31}(-1)^{3+1}M_{31} \\
 |A| &= a_{11}A_{11} + a_{21}A_{21} + a_{31}A_{31}
 \end{aligned}$$

From the above discussion it is clear that, $|A|$ can be evaluated by adding the product of elements with corresponding cofactors of any row or column of the matrix.

Example: If $A = \begin{bmatrix} 1 & 2 & 6 \\ 0 & 1 & 2 \\ -1 & 3 & 0 \end{bmatrix}$; then find $|A|$ using cofactors.

Solution:

First, we find cofactors of any one of the row or column of the given matrix. Let us find the cofactors of C_3 . The elements of C_3 are a_{13}, a_{23} and a_{33} . In this case $a_{13} = 6, a_{23} = 2$ and $a_{33} = 0$. Now we find their corresponding cofactors.

$$A_{13} = (-1)^{1+3} \begin{vmatrix} 0 & 1 \\ -1 & 3 \end{vmatrix} = (-1)^4(0 - (-1)) = 1(1) = 1$$

$$A_{23} = (-1)^{2+3} \begin{vmatrix} 1 & 2 \\ -1 & 3 \end{vmatrix} = (-1)^5(3 - (-2)) = (-1)(5) = -5$$

$$A_{33} = (-1)^{3+3} \begin{vmatrix} 1 & 2 \\ 0 & 1 \end{vmatrix} = (-1)^6(1 - 0) = (1)(1) = 1$$

$$\begin{aligned}
 \therefore |A| &= a_{13}A_{13} + a_{23}A_{23} + a_{33}A_{33} \\
 &= 6(1) + 2(-5) + 0(1) = 6 - 10 + 0 = -4
 \end{aligned}$$

2.3.3 Singular and Non-Singular Matrices

Any square matrix A is called **singular** if $|A| = 0$.

If $|A| \neq 0$ then it is called **non-singular** matrix.

For example, for the matrices $A = \begin{bmatrix} 1 & 3 \\ 4 & 2 \end{bmatrix}$ and $B = \begin{bmatrix} 3 & 12 \\ \frac{1}{2} & 2 \end{bmatrix}$.

$$|A| = \begin{vmatrix} 1 & 3 \\ 4 & 2 \end{vmatrix} = (1)(2) - (3)(4) = 2 - 12 = -10 \neq 0$$

$$|B| = \begin{vmatrix} 3 & 12 \\ \frac{1}{2} & 2 \end{vmatrix} = (3)(2) - 12\left(\frac{1}{2}\right) = 6 - 6 = 0$$

Thus A is non-singular matrix and B is singular matrix.

2.3.4 Adjoint of a Square Matrix

Consider any square matrix A of order n :

$$A = \begin{bmatrix} a_{11} & a_{12} & \dots & \dots & a_{1n} \\ a_{21} & a_{22} & \dots & \dots & a_{2n} \\ \vdots & \vdots & \dots & \dots & \vdots \\ \vdots & \vdots & \dots & \dots & \vdots \\ a_{n1} & a_{n2} & \dots & \dots & a_{nn} \end{bmatrix} \text{ then the adjoint of } A \text{ is written as } adj(A) \text{ and is the matrix}$$

$$adj(A) = \begin{bmatrix} A_{11} & A_{21} & \dots & \dots & A_{n1} \\ A_{12} & A_{22} & \dots & \dots & A_{n2} \\ \vdots & \vdots & \dots & \dots & \vdots \\ \vdots & \vdots & \dots & \dots & \vdots \\ A_{1n} & A_{2n} & \dots & \dots & A_{nn} \end{bmatrix}$$

If the order of the matrix A is 3×3 . i.e.

$$A = \begin{bmatrix} a_{11} & a_{12} & a_{13} \\ a_{21} & a_{22} & a_{23} \\ a_{31} & a_{32} & a_{33} \end{bmatrix} \text{ then } adj(A) = \begin{bmatrix} A_{11} & A_{21} & A_{31} \\ A_{12} & A_{22} & A_{32} \\ A_{13} & A_{23} & A_{33} \end{bmatrix}$$

Multiplicative Inverse of a Square Matrix

Two square matrices of same order n are said to be the multiplicative inverses of each other if their product is I_n (identity matrix of order n).

Only non-singular matrices have their multiplicative inverses.

If A is a non-singular matrix then its multiplicative inverse is denoted by A^{-1} and

$$AA^{-1} = A^{-1}A = I$$

2.3.5 Adjoint Method to Find the Inverse of a Non-Singular Matrix

If A is a non-singular square matrix i.e.; $|A| \neq 0$ then $A^{-1} = \frac{1}{|A|} adj(A)$

Obviously if A is a singular then $|A| = 0$, then $A^{-1} = \frac{1}{|A|} adj(A)$ will not exist.

Example: If $A = \begin{bmatrix} 2 & 1 & 0 \\ 0 & 3 & 2 \\ 2 & 1 & 4 \end{bmatrix}$ then find A^{-1} by adjoint method.

Solution:

$$\begin{aligned} \text{Since } |A| &= \begin{vmatrix} 2 & 1 & 0 \\ 0 & 3 & 2 \\ 2 & 1 & 4 \end{vmatrix} \\ \Rightarrow |A| &= 2 \begin{vmatrix} 3 & 2 \\ 1 & 4 \end{vmatrix} - 1 \begin{vmatrix} 0 & 2 \\ 2 & 4 \end{vmatrix} + 0 \begin{vmatrix} 0 & 3 \\ 2 & 1 \end{vmatrix} \end{aligned}$$

$$= 2(12 - 2) - 1(0 - 4) + 0(0 - 6) = 20 + 4 + 0 = 24 \neq 0$$

Thus, A is non-singular. To find the adjoint of A we find cofactors of all the elements of A .

$$A_{11} = (-1)^{1+1} \begin{vmatrix} 3 & 2 \\ 1 & 4 \end{vmatrix} = (-1)^2(12 - 2) = (1)(10) = 10$$

$$A_{12} = (-1)^{1+2} \begin{vmatrix} 0 & 2 \\ 2 & 4 \end{vmatrix} = (-1)^3(0 - 4) = (-1)(-4) = 4$$

$$A_{13} = (-1)^{1+3} \begin{vmatrix} 0 & 3 \\ 2 & 1 \end{vmatrix} = (-1)^4(0 - 6) = (1)(-6) = -6$$

Key Facts



- $A^{-1} \neq \frac{1}{A}$
- If the inverse of matrix A exists then it is unique.

$$A_{21} = (-1)^{2+1} \begin{vmatrix} 1 & 0 \\ 1 & 4 \end{vmatrix} = (-1)^3(4 - 0) = (-1)(4) = -4$$

$$A_{22} = (-1)^{2+2} \begin{vmatrix} 2 & 0 \\ 2 & 4 \end{vmatrix} = (-1)^4(8 - 0) = (1)(8) = 8$$

$$A_{23} = (-1)^{2+3} \begin{vmatrix} 2 & 1 \\ 2 & 1 \end{vmatrix} = (-1)^5(2 - 2) = (-1)(0) = 0$$

$$A_{31} = (-1)^{3+1} \begin{vmatrix} 1 & 0 \\ 3 & 2 \end{vmatrix} = (-1)^4(2 - 0) = (1)(2) = 2$$

$$A_{32} = (-1)^{3+2} \begin{vmatrix} 2 & 0 \\ 0 & 2 \end{vmatrix} = (-1)^5(4 - 0) = (-1)(4) = -4$$

$$A_{33} = (-1)^{3+3} \begin{vmatrix} 2 & 1 \\ 0 & 3 \end{vmatrix} = (-1)^6(6 - 0) = (1)(6) = 6$$

Now $adj(A) = \begin{bmatrix} A_{11} & A_{21} & A_{31} \\ A_{12} & A_{22} & A_{32} \\ A_{13} & A_{23} & A_{33} \end{bmatrix} = \begin{bmatrix} 10 & -4 & 2 \\ 4 & 8 & -4 \\ -6 & 0 & 6 \end{bmatrix}$

$$\text{And } A^{-1} = \frac{1}{|A|} adj(A) = \frac{1}{24} \begin{bmatrix} 10 & -4 & 2 \\ 4 & 8 & -4 \\ -6 & 0 & 6 \end{bmatrix} = \begin{bmatrix} \frac{10}{24} & -\frac{4}{24} & \frac{2}{24} \\ \frac{4}{24} & \frac{8}{24} & -\frac{4}{24} \\ -\frac{6}{24} & \frac{0}{24} & \frac{6}{24} \end{bmatrix}$$

$$A^{-1} = \begin{bmatrix} 5/12 & -1/6 & 1/12 \\ 1/6 & 1/3 & -1/6 \\ -1/4 & 0 & 1/4 \end{bmatrix}$$

2.3.6 Verification of the Result $(AB)^{-1} = B^{-1}A^{-1}$

If A and B are square matrices of the same order then $(AB)^{-1} = B^{-1}A^{-1}$: To verify this, consider two matrices A and B of the same order.

Let $A = \begin{bmatrix} 3 & 2 \\ 1 & 4 \end{bmatrix}$ and $B = \begin{bmatrix} 1 & 2 \\ 4 & 3 \end{bmatrix}$

For L.H.S.

$$AB = \begin{bmatrix} 3 & 2 \\ 1 & 4 \end{bmatrix} \begin{bmatrix} 1 & 2 \\ 4 & 3 \end{bmatrix} = \begin{bmatrix} 3+8 & 6+6 \\ 1+16 & 2+12 \end{bmatrix} = \begin{bmatrix} 11 & 12 \\ 17 & 14 \end{bmatrix}$$

$$|AB| = \begin{vmatrix} 11 & 12 \\ 17 & 14 \end{vmatrix} = (11)(14) - (17)(12) = 154 - 204 = -50$$

And $adj(AB) = \begin{bmatrix} 14 & -12 \\ -17 & 11 \end{bmatrix}$

$\therefore (AB)^{-1} = \frac{1}{|AB|} adj(AB)$ so

$$(AB)^{-1} = \frac{1}{-50} \begin{bmatrix} 14 & -12 \\ -17 & 11 \end{bmatrix} = \begin{bmatrix} \frac{14}{-50} & \frac{-12}{-50} \\ \frac{-17}{-50} & \frac{11}{-50} \end{bmatrix}$$

$$(AB)^{-1} = \begin{bmatrix} -\frac{7}{25} & \frac{6}{25} \\ \frac{17}{50} & -\frac{11}{50} \end{bmatrix}$$

(1)



Key Facts
 $(AB)^{-1} = B^{-1}A^{-1}$ is known
as reversal law of inverse.

For R.H.S.

$$|A| = \begin{vmatrix} 3 & 2 \\ 1 & 4 \end{vmatrix} = (3)(4) - (1)(2) = 12 - 2 = 10$$

$$\text{adj}(A) = \begin{bmatrix} 4 & -2 \\ -1 & 3 \end{bmatrix} \text{ and}$$

$$A^{-1} = \frac{1}{|A|} \text{adj}(A) = \frac{1}{10} \begin{bmatrix} 4 & -2 \\ -1 & 3 \end{bmatrix} = \begin{bmatrix} 4/10 & -2/10 \\ -1/10 & 3/10 \end{bmatrix} = \begin{bmatrix} 2/5 & -1/5 \\ -1/10 & 3/10 \end{bmatrix}$$

$$\text{And } |B| = \begin{vmatrix} 1 & 2 \\ 4 & 3 \end{vmatrix} = (1)(3) - (4)(2) = 3 - 8 = -5$$

$$\text{adj}(B) = \begin{bmatrix} 3 & -2 \\ -4 & 1 \end{bmatrix} \text{ and}$$

$$B^{-1} = \frac{1}{|B|} \text{adj}(B) = \frac{1}{-5} \begin{bmatrix} 3 & -2 \\ -4 & 1 \end{bmatrix} = \begin{bmatrix} 3/-5 & -2/-5 \\ -4/-5 & 1/-5 \end{bmatrix} = \begin{bmatrix} -3/5 & 2/5 \\ 4/5 & -1/5 \end{bmatrix}$$

$$\begin{aligned} B^{-1}A^{-1} &= \begin{bmatrix} -3/5 & 2/5 \\ 4/5 & -1/5 \end{bmatrix} \begin{bmatrix} 2/5 & -1/5 \\ -1/10 & 3/10 \end{bmatrix} \\ &= \begin{bmatrix} \left(-\frac{3}{5}\right)\left(\frac{2}{5}\right) + \left(\frac{2}{5}\right)\left(\frac{-1}{10}\right) & \left(-\frac{3}{5}\right)\left(\frac{-1}{5}\right) + \left(\frac{2}{5}\right)\left(\frac{3}{10}\right) \\ \left(\frac{4}{5}\right)\left(\frac{2}{5}\right) + \left(\frac{-1}{5}\right)\left(\frac{-1}{10}\right) & \left(\frac{4}{5}\right)\left(\frac{-1}{5}\right) + \left(\frac{-1}{5}\right)\left(\frac{3}{10}\right) \end{bmatrix} \\ &= \begin{bmatrix} \frac{-6}{25} - \frac{1}{25} & \frac{3}{25} + \frac{3}{25} \\ \frac{8}{25} + \frac{1}{50} & \frac{-4}{25} - \frac{3}{50} \end{bmatrix} = \begin{bmatrix} \frac{-7}{25} & \frac{6}{25} \\ \frac{17}{50} & \frac{-11}{50} \end{bmatrix} \end{aligned} \quad (2)$$

From (1) and (2) we have $(AB)^{-1} = B^{-1}A^{-1}$

Exercise 2.3

1. Evaluate the determinant of the following matrices.

(i) $\begin{vmatrix} 2 & 3 & 1 \\ 1 & -1 & 2 \\ 4 & 1 & 2 \end{vmatrix}$

(ii) $\begin{bmatrix} \cos \theta & -\sin \theta & 0 \\ \sin \theta & \cos \theta & 0 \\ 0 & 0 & 1 \end{bmatrix}$

(iii) $\begin{vmatrix} i & 3 & -2i \\ 1 & 3 & 4 \\ 0 & 1 & 2 \end{vmatrix}$

(iv) $\begin{bmatrix} 2+i & 1 & i \\ 0 & 2 & 1 \\ -3i & 1 & 6 \end{bmatrix}$

2. Evaluate the determinants of the following matrices using cofactor method.

(i) $\begin{vmatrix} 3 & 2 & 3 \\ 4 & 5 & 1 \\ 2 & 1 & 0 \end{vmatrix}$

(ii) $\begin{bmatrix} 2 & 3 & -1 \\ -1 & 0 & 2 \\ 3 & 1 & 4 \end{bmatrix}$

$$(iii) \begin{bmatrix} 2i & 6 & 1 \\ 1 & -i & 2 \\ 0 & 1 & 3i \end{bmatrix}$$

$$(iv) \begin{bmatrix} 1-i & 2 & 1+i \\ 3 & 1 & 4 \\ 0 & 2 & 3 \end{bmatrix}$$

3. Determine which of the following matrices are singular and which are non-singular.

$$(i) \begin{bmatrix} 3 & 1 & 2 \\ 2 & 3 & 1 \\ -4 & 1 & -3 \end{bmatrix}$$

$$(ii) \begin{bmatrix} 3 & -1 & 2 \\ 2 & 0 & 1 \\ -1 & 5 & 1 \end{bmatrix}$$

$$(iii) \begin{bmatrix} 3i & 1 & 2 \\ -4 & 1 & i \\ 2 & 0 & 1 \end{bmatrix}$$

$$(iv) \begin{bmatrix} 2 & -i & 1 \\ i & 3 & -2 \\ -2+i & i+3 & -3 \end{bmatrix}$$

4. Find the value of λ , so that the given matrices are singular.

$$(i) \begin{bmatrix} \lambda & 1 & 3 \\ 2 & 1 & 8 \\ 0 & 3 & 1 \end{bmatrix}$$

$$(ii) \begin{bmatrix} \lambda & 2 & 0 \\ 2 & 1 & 3 \\ \lambda & 2 & 1 \end{bmatrix}$$

$$(iii) \begin{bmatrix} \lambda & i & 1 \\ 2 & 1 & 3 \\ 3 & 1 & 2 \end{bmatrix}$$

$$(iv) \begin{bmatrix} 2+i & 1 & 6 \\ 2 & \lambda & 1 \\ 3 & 0 & 2 \end{bmatrix}$$

5. Find the multiplicative inverse of the following matrices if it exists by adjoint method.

$$(i) \begin{bmatrix} 1 & -1 & 1 \\ 2 & 1 & -1 \\ 1 & -2 & -1 \end{bmatrix}$$

$$(ii) \begin{bmatrix} 3 & -4 & 2 \\ 2 & 3 & 5 \\ 1 & 0 & 1 \end{bmatrix}$$

$$(iii) \begin{bmatrix} i & 0 & 1 \\ 2i & -1 & -i \\ 1 & 0 & 4i \end{bmatrix}$$

$$(iv) \begin{bmatrix} 3 & -i & i \\ 2 & 1 & -3i \\ 4i & 2 & 6 \end{bmatrix}$$

6. If $A = \begin{bmatrix} 2 & 1 & -3 \\ 0 & 1 & 0 \\ 2 & 1 & 6 \end{bmatrix}$ then find A^{-1} and hence show that $AA^{-1} = A^{-1}A = I_3$.

7. Verify that $(AB)^{-1} = B^{-1}A^{-1}$ in each of the following.

$$(i) A = \begin{bmatrix} 2 & 1 \\ 8 & 6 \end{bmatrix} \text{ and } B = \begin{bmatrix} 3 & 2 \\ 0 & 2 \end{bmatrix}$$

$$(ii) A = \begin{bmatrix} 1 & 1 & 1 \\ 2 & -1 & 1 \\ 2 & 1 & -3 \end{bmatrix} \text{ and } B = \begin{bmatrix} 3 & -2 & 3 \\ 2 & 1 & -1 \\ 4 & -3 & 2 \end{bmatrix}$$

$$(iii) A = \begin{bmatrix} 2 & -i & 6 \\ 1 & 2 & i \\ -i & 1 & 6 \end{bmatrix} \text{ and } B = \begin{bmatrix} 3 & 1 & 2 \\ 1 & 0 & 1 \\ 0 & 1 & 1 \end{bmatrix}$$

$$(iv) A = \begin{bmatrix} 1 & 2 & 5 \\ 1 & -1 & -1 \\ 2 & 3 & -1 \end{bmatrix} \text{ and } B = \begin{bmatrix} 2 & 3 & 4 \\ 1 & 0 & 2 \\ 0 & 1 & 3 \end{bmatrix}$$

2.4 Properties of Determinants

Here we will discuss some important properties of determinants which will help us to find the value of a determinant. For convenience we will consider the determinant of the square matrix A of order 3×3 i.e. if

$$A = \begin{bmatrix} a_{11} & a_{12} & a_{13} \\ a_{21} & a_{22} & a_{23} \\ a_{31} & a_{32} & a_{33} \end{bmatrix} \text{ then}$$

$$|A| = \begin{vmatrix} a_{11} & a_{12} & a_{13} \\ a_{21} & a_{22} & a_{23} \\ a_{31} & a_{32} & a_{33} \end{vmatrix}$$

$$\begin{aligned} |A| &= a_{11} \begin{vmatrix} a_{22} & a_{23} \\ a_{32} & a_{33} \end{vmatrix} - a_{12} \begin{vmatrix} a_{21} & a_{23} \\ a_{31} & a_{33} \end{vmatrix} + a_{13} \begin{vmatrix} a_{21} & a_{22} \\ a_{31} & a_{32} \end{vmatrix} \\ &= a_{11}(a_{22}a_{33} - a_{23}a_{32}) - a_{12}(a_{21}a_{33} - a_{23}a_{31}) + a_{13}(a_{21}a_{32} - a_{22}a_{31}) \end{aligned}$$

Property 1:

$$|A| = |A^t|$$

Proof:

$$|A^t| = \begin{vmatrix} a_{11} & a_{21} & a_{31} \\ a_{12} & a_{22} & a_{32} \\ a_{13} & a_{23} & a_{33} \end{vmatrix}$$

Expanding from C_1 ; we have,

$$\begin{aligned} |A^t| &= a_{11} \begin{vmatrix} a_{22} & a_{32} \\ a_{23} & a_{33} \end{vmatrix} - a_{21} \begin{vmatrix} a_{21} & a_{31} \\ a_{23} & a_{33} \end{vmatrix} + a_{31} \begin{vmatrix} a_{21} & a_{31} \\ a_{22} & a_{32} \end{vmatrix} \\ &= a_{11}(a_{22}a_{33} - a_{23}a_{32}) - a_{21}(a_{21}a_{33} - a_{23}a_{31}) + a_{31}(a_{21}a_{32} - a_{22}a_{31}) \\ &= |A| \end{aligned}$$

Example:

$$\text{If } A = \begin{bmatrix} 1 & 2 & 0 \\ 0 & 3 & 0 \\ 2 & 1 & 6 \end{bmatrix} \text{ then } |A| = \begin{vmatrix} 1 & 2 & 0 \\ 0 & 3 & 0 \\ 2 & 1 & 6 \end{vmatrix}$$

$$\begin{aligned} &= 1 \begin{vmatrix} 3 & 0 \\ 1 & 6 \end{vmatrix} - 2 \begin{vmatrix} 0 & 0 \\ 2 & 6 \end{vmatrix} + 0 \begin{vmatrix} 0 & 3 \\ 2 & 1 \end{vmatrix} \\ &= 1(18 - 0) - 2(0 - 0) + 0 = 18 \end{aligned}$$

And

$$\begin{aligned} |A^t| &= \begin{vmatrix} 1 & 0 & 2 \\ 2 & 3 & 1 \\ 0 & 0 & 6 \end{vmatrix} = 1 \begin{vmatrix} 3 & 1 \\ 0 & 6 \end{vmatrix} - 0 \begin{vmatrix} 2 & 1 \\ 0 & 6 \end{vmatrix} + 2 \begin{vmatrix} 2 & 3 \\ 0 & 0 \end{vmatrix} \\ &= 1(18 - 0) - 0 + 2(0 - 0) = 18 \end{aligned}$$

Thus $|A| = |A^t|$

Property 2:

If any two rows (or columns) of a square matrix A are interchanged such that the resulting matrix is B then $|B| = -|A|$.

Proof:

Let we interchange the first and second rows of matrix A ; then the new matrix is:

$$\begin{aligned}
 B &= \begin{bmatrix} a_{21} & a_{22} & a_{23} \\ a_{11} & a_{12} & a_{13} \\ a_{31} & a_{32} & a_{33} \end{bmatrix} \\
 \Rightarrow |B| &= \begin{vmatrix} a_{21} & a_{22} & a_{23} \\ a_{11} & a_{12} & a_{13} \\ a_{31} & a_{32} & a_{33} \end{vmatrix} \\
 &= a_{21} \begin{vmatrix} a_{12} & a_{13} \\ a_{32} & a_{33} \end{vmatrix} - a_{22} \begin{vmatrix} a_{11} & a_{13} \\ a_{31} & a_{33} \end{vmatrix} + a_{23} \begin{vmatrix} a_{11} & a_{12} \\ a_{31} & a_{32} \end{vmatrix} \\
 &= a_{21}(a_{12}a_{33} - a_{13}a_{32}) - a_{22}(a_{11}a_{33} - a_{13}a_{31}) + a_{23}(a_{11}a_{32} - a_{12}a_{31}) \\
 &= a_{12}a_{21}a_{33} - a_{13}a_{21}a_{32} - a_{11}a_{22}a_{33} + a_{13}a_{22}a_{31} + a_{11}a_{23}a_{32} - a_{12}a_{23}a_{31} \\
 &= (-a_{11}a_{22}a_{33} + a_{11}a_{23}a_{32}) + (a_{12}a_{21}a_{33} - a_{12}a_{23}a_{31}) + (-a_{13}a_{21}a_{32} + a_{13}a_{22}a_{31}) \\
 &= -a_{11}(a_{22}a_{33} - a_{23}a_{32}) + a_{12}(a_{21}a_{33} - a_{23}a_{31}) - a_{13}(a_{21}a_{32} - a_{22}a_{31}) \\
 &= -[a_{11}(a_{22}a_{33} - a_{23}a_{32}) - a_{12}(a_{21}a_{33} - a_{23}a_{31}) + a_{13}(a_{21}a_{32} - a_{22}a_{31})] \\
 \Rightarrow |B| &= -|A|
 \end{aligned}$$

Example: Let $A = \begin{bmatrix} 1 & 2 & 3 \\ 2 & 1 & 0 \\ 0 & 2 & 0 \end{bmatrix}$ then

$$|A| = 1 \begin{vmatrix} 1 & 0 \\ 2 & 0 \end{vmatrix} - 2 \begin{vmatrix} 2 & 0 \\ 0 & 0 \end{vmatrix} + 3 \begin{vmatrix} 2 & 1 \\ 0 & 2 \end{vmatrix} = 1(0 - 0) - 2(0 - 0) + 3(4 - 0) = 12$$

By interchanging second and third rows of A ; we have a matrix $B = \begin{bmatrix} 1 & 2 & 3 \\ 0 & 2 & 0 \\ 2 & 1 & 0 \end{bmatrix}$

$$\begin{aligned}
 \Rightarrow |B| &= \begin{vmatrix} 1 & 2 & 3 \\ 0 & 2 & 0 \\ 2 & 1 & 0 \end{vmatrix} = 1 \begin{vmatrix} 2 & 0 \\ 1 & 0 \end{vmatrix} - 2 \begin{vmatrix} 0 & 0 \\ 2 & 0 \end{vmatrix} + 3 \begin{vmatrix} 0 & 2 \\ 2 & 1 \end{vmatrix} \\
 &= 1(0 - 0) - 2(0 - 0) + 3(0 - 4) = 0 - 0 - 12 = -12 \\
 |B| &= -|A|
 \end{aligned}$$

Property 3:

If any two rows (or columns) of a square matrix are identical then the value of the determinant is zero.

Proof:

Consider a determinant with two identical rows:

$$\begin{aligned}
 \begin{vmatrix} a_{11} & a_{12} & a_{13} \\ a_{21} & a_{22} & a_{23} \\ a_{21} & a_{22} & a_{23} \end{vmatrix} &= a_{11} \begin{vmatrix} a_{22} & a_{23} \\ a_{22} & a_{23} \end{vmatrix} - a_{12} \begin{vmatrix} a_{21} & a_{23} \\ a_{21} & a_{23} \end{vmatrix} + a_{13} \begin{vmatrix} a_{21} & a_{22} \\ a_{21} & a_{22} \end{vmatrix} \\
 &= a_{11}(a_{22}a_{23} - a_{22}a_{23}) - a_{12}(a_{21}a_{23} - a_{21}a_{23}) + a_{13}(a_{21}a_{22} - a_{21}a_{22}) \\
 &= a_{11}(0) - a_{12}(0) + a_{13}(0) = 0 + 0 + 0 = 0
 \end{aligned}$$

Example: Consider the determinant $\Delta = \begin{vmatrix} 2 & 1 & 6 \\ 3 & 2 & 0 \\ 3 & 2 & 0 \end{vmatrix}$

Expanding by R_1 :

$$\begin{aligned} \Delta &= 2 \begin{vmatrix} 2 & 0 \\ 3 & 0 \end{vmatrix} - 1 \begin{vmatrix} 3 & 0 \\ 3 & 0 \end{vmatrix} + 6 \begin{vmatrix} 3 & 2 \\ 3 & 2 \end{vmatrix} \\ &= 2(0 - 0) - 1(0 - 0) + 6(6 - 6) \\ &= 2(0) - 1(0) + 6(0) = 0 \end{aligned}$$

Property 4:

If we multiply each element of a row or a column with a non-zero scalar k then the resulting matrix is B and $|B| = k|A|$

Proof:

$$A = \begin{bmatrix} a_{11} & a_{12} & a_{13} \\ a_{21} & a_{22} & a_{23} \\ a_{31} & a_{32} & a_{33} \end{bmatrix}$$

Let we multiply each element of row one by a non-zero scalar k then the resulting matrix is

$$B = \begin{bmatrix} ka_{11} & ka_{12} & ka_{13} \\ a_{21} & a_{22} & a_{23} \\ a_{31} & a_{32} & a_{33} \end{bmatrix}$$

$$\Rightarrow |B| = \begin{vmatrix} ka_{11} & ka_{12} & ka_{13} \\ a_{21} & a_{22} & a_{23} \\ a_{31} & a_{32} & a_{33} \end{vmatrix} = ka_{11} \begin{vmatrix} a_{22} & a_{23} \\ a_{32} & a_{33} \end{vmatrix} - ka_{12} \begin{vmatrix} a_{21} & a_{23} \\ a_{31} & a_{33} \end{vmatrix} + ka_{13} \begin{vmatrix} a_{21} & a_{22} \\ a_{31} & a_{32} \end{vmatrix}$$

$$= k \left\{ a_{11} \begin{vmatrix} a_{22} & a_{23} \\ a_{32} & a_{33} \end{vmatrix} - a_{12} \begin{vmatrix} a_{21} & a_{23} \\ a_{31} & a_{33} \end{vmatrix} + a_{13} \begin{vmatrix} a_{21} & a_{22} \\ a_{31} & a_{32} \end{vmatrix} \right\}$$

$$= k \begin{vmatrix} a_{11} & a_{12} & a_{13} \\ a_{21} & a_{22} & a_{23} \\ a_{31} & a_{32} & a_{33} \end{vmatrix}$$

Thus $|B| = k|A|$

Example: Let $A = \begin{bmatrix} 1 & 3 & 2 \\ 2 & 1 & 0 \\ 1 & 0 & 3 \end{bmatrix}$

Let we multiply each element of second row by 3 then the resulting matrix is $B = \begin{bmatrix} 1 & 3 & 2 \\ 6 & 3 & 0 \\ 1 & 0 & 3 \end{bmatrix}$.

$$\begin{aligned} \text{Now } |A| &= \begin{vmatrix} 1 & 3 & 2 \\ 2 & 1 & 0 \\ 1 & 0 & 3 \end{vmatrix} = 1 \begin{vmatrix} 1 & 0 \\ 1 & 3 \end{vmatrix} - 3 \begin{vmatrix} 2 & 0 \\ 1 & 3 \end{vmatrix} + 2 \begin{vmatrix} 2 & 1 \\ 1 & 0 \end{vmatrix} \\ &= 1(3 - 0) - 3(6 - 0) + 2(0 - 1) = 3 - 18 - 2 = -17 \end{aligned}$$

$$\begin{aligned} \text{And } |B| &= \begin{vmatrix} 1 & 3 & 2 \\ 6 & 3 & 0 \\ 1 & 0 & 3 \end{vmatrix} = 1 \begin{vmatrix} 3 & 0 \\ 0 & 3 \end{vmatrix} - 3 \begin{vmatrix} 6 & 0 \\ 1 & 3 \end{vmatrix} + 2 \begin{vmatrix} 6 & 3 \\ 1 & 0 \end{vmatrix} \\ &= 1(9 - 0) - 3(18 - 0) + 2(0 - 3) = 9 - 54 - 6 = -51 \\ &= 3(-17) = 3|A| \end{aligned}$$

i.e.; $|B| = 3|A|$

Property 5:

If matrix A is of the form

$$A = \begin{bmatrix} a_{11} + b_{11} & a_{12} & a_{13} \\ a_{21} + b_{21} & a_{22} & a_{23} \\ a_{31} + b_{31} & a_{32} & a_{33} \end{bmatrix}; \text{ then}$$

$$|A| = \begin{vmatrix} a_{11} & a_{12} & a_{13} \\ a_{21} & a_{22} & a_{23} \\ a_{31} & a_{32} & a_{33} \end{vmatrix} + \begin{vmatrix} b_{11} & a_{12} & a_{13} \\ b_{21} & a_{22} & a_{23} \\ b_{31} & a_{32} & a_{33} \end{vmatrix}$$

Proof:

$$|A| = \begin{vmatrix} a_{11} + b_{11} & a_{12} & a_{13} \\ a_{21} + b_{21} & a_{22} & a_{23} \\ a_{31} + b_{31} & a_{32} & a_{33} \end{vmatrix}$$

Expanding from C_1

$$\begin{aligned} &= (a_{11} + b_{11}) \begin{vmatrix} a_{22} & a_{23} \\ a_{32} & a_{33} \end{vmatrix} - (a_{21} + b_{21}) \begin{vmatrix} a_{12} & a_{13} \\ a_{32} & a_{33} \end{vmatrix} + (a_{31} + b_{31}) \begin{vmatrix} a_{12} & a_{13} \\ a_{22} & a_{23} \end{vmatrix} \\ &= a_{11} \begin{vmatrix} a_{22} & a_{23} \\ a_{32} & a_{33} \end{vmatrix} + b_{11} \begin{vmatrix} a_{22} & a_{23} \\ a_{32} & a_{33} \end{vmatrix} - a_{21} \begin{vmatrix} a_{12} & a_{13} \\ a_{32} & a_{33} \end{vmatrix} - b_{21} \begin{vmatrix} a_{12} & a_{13} \\ a_{32} & a_{33} \end{vmatrix} + a_{31} \begin{vmatrix} a_{12} & a_{13} \\ a_{22} & a_{23} \end{vmatrix} \\ &\quad + b_{31} \begin{vmatrix} a_{12} & a_{13} \\ a_{22} & a_{23} \end{vmatrix} \\ &= \left(a_{11} \begin{vmatrix} a_{22} & a_{23} \\ a_{32} & a_{33} \end{vmatrix} - a_{21} \begin{vmatrix} a_{12} & a_{13} \\ a_{32} & a_{33} \end{vmatrix} + a_{31} \begin{vmatrix} a_{12} & a_{13} \\ a_{22} & a_{23} \end{vmatrix} \right) \\ &\quad + \left(b_{11} \begin{vmatrix} a_{22} & a_{23} \\ a_{32} & a_{33} \end{vmatrix} - b_{21} \begin{vmatrix} a_{12} & a_{13} \\ a_{32} & a_{33} \end{vmatrix} + b_{31} \begin{vmatrix} a_{12} & a_{13} \\ a_{22} & a_{23} \end{vmatrix} \right) \\ &= \begin{vmatrix} a_{11} & a_{12} & a_{13} \\ a_{21} & a_{22} & a_{23} \\ a_{31} & a_{32} & a_{33} \end{vmatrix} + \begin{vmatrix} b_{11} & a_{12} & a_{13} \\ b_{21} & a_{22} & a_{23} \\ b_{31} & a_{32} & a_{33} \end{vmatrix} \end{aligned}$$

Example: If $A = \begin{bmatrix} 1+2 & 1 & 0 \\ 3-1 & 0 & 2 \\ 2+3 & 2 & 1 \end{bmatrix}$ then

$$\begin{vmatrix} 1+2 & 1 & 0 \\ 3-1 & 0 & 2 \\ 2+3 & 2 & 1 \end{vmatrix} = \begin{vmatrix} 1 & 1 & 0 \\ 3 & 0 & 2 \\ 2 & 2 & 1 \end{vmatrix} + \begin{vmatrix} 2 & 1 & 0 \\ -1 & 0 & 2 \\ 3 & 2 & 1 \end{vmatrix}$$

$$\text{L.H.S. } \begin{vmatrix} 1+2 & 1 & 0 \\ 3-1 & 0 & 2 \\ 2 & 2 & 1 \end{vmatrix} = \begin{vmatrix} 3 & 1 & 0 \\ 2 & 0 & 2 \\ 5 & 2 & 1 \end{vmatrix}$$

$$\begin{aligned} &= 3 \begin{vmatrix} 0 & 2 \\ 2 & 1 \end{vmatrix} - 1 \begin{vmatrix} 2 & 2 \\ 5 & 1 \end{vmatrix} + 0 \begin{vmatrix} 2 & 0 \\ 5 & 2 \end{vmatrix} = 3(0 - 4) - 1(2 - 10) + 0(4 - 0) \\ &= -12 + 8 + 0 = -4 \end{aligned}$$

(1)

$$\begin{aligned}
 \text{R.H.S. } & \begin{vmatrix} 1 & 1 & 0 \\ 3 & 0 & 2 \\ 2 & 2 & 1 \end{vmatrix} + \begin{vmatrix} 2 & 1 & 0 \\ -1 & 0 & 2 \\ 3 & 2 & 1 \end{vmatrix} \\
 & = (1 \begin{vmatrix} 0 & 2 \\ 2 & 1 \end{vmatrix} - 1 \begin{vmatrix} 3 & 2 \\ 2 & 1 \end{vmatrix} + 0 \begin{vmatrix} 3 & 0 \\ 2 & 2 \end{vmatrix}) + (2 \begin{vmatrix} 0 & 2 \\ 2 & 1 \end{vmatrix} - 1 \begin{vmatrix} -1 & 2 \\ 3 & 1 \end{vmatrix} + 0 \begin{vmatrix} -1 & 0 \\ 3 & 2 \end{vmatrix}) \\
 & = (1(0 - 4) - 1(3 - 4) + 0) + (2(0 - 4) - 1(-1 - 6) + 0) \\
 & = (-4 + 1 + 0) + (-8 + 7 + 0) = -4 \tag{2}
 \end{aligned}$$

Property 6:

If all the elements of a row or a column of a square matrix A are zero then $|A| = 0$

Proof:

Consider the matrix $A = \begin{bmatrix} a_{11} & a_{12} & a_{13} \\ 0 & 0 & 0 \\ a_{31} & a_{32} & a_{33} \end{bmatrix}$

So $|A| = \begin{vmatrix} a_{11} & a_{12} & a_{13} \\ 0 & 0 & 0 \\ a_{31} & a_{32} & a_{33} \end{vmatrix}$

Expanding from R_1

$$\begin{aligned}
 |A| & = a_{11} \begin{vmatrix} 0 & 0 \\ a_{32} & a_{33} \end{vmatrix} - a_{12} \begin{vmatrix} 0 & 0 \\ a_{31} & a_{33} \end{vmatrix} + a_{13} \begin{vmatrix} 0 & 0 \\ a_{31} & a_{32} \end{vmatrix} \\
 & = a_{11}(0 - 0) - a_{12}(0 - 0) + a_{13}(0 - 0) = 0 + 0 + 0 = 0
 \end{aligned}$$

Example: If $A = \begin{bmatrix} 3 & 1 & 2 \\ 0 & 0 & 0 \\ 1 & 3 & 9 \end{bmatrix}$ then

$$\begin{aligned}
 |A| & = \begin{vmatrix} 3 & 1 & 2 \\ 0 & 0 & 0 \\ 1 & 3 & 9 \end{vmatrix} \\
 & = 3 \begin{vmatrix} 0 & 0 \\ 3 & 9 \end{vmatrix} - 1 \begin{vmatrix} 0 & 0 \\ 1 & 9 \end{vmatrix} + 2 \begin{vmatrix} 0 & 0 \\ 1 & 3 \end{vmatrix} = 3(0 - 0) - 1(0 - 0) + 2(0 - 0) \\
 & = 0 - 0 + 0 = 0
 \end{aligned}$$

Property 7:

If we multiply any row (column) of a square matrix with some scalar k and add the resulting value to the corresponding elements of any other row (column) then the value of the determinant is unchanged.

Proof:

Consider any square matrix $A = \begin{bmatrix} a_{11} & a_{12} & a_{13} \\ a_{21} & a_{22} & a_{23} \\ a_{31} & a_{32} & a_{33} \end{bmatrix}$

$$\Rightarrow |A| = \begin{vmatrix} a_{11} & a_{12} & a_{13} \\ a_{21} & a_{22} & a_{23} \\ a_{31} & a_{32} & a_{33} \end{vmatrix}$$

Let we multiply R_2 by k and then add the result in R_1 . Resulting matrix is:

$$B = \begin{bmatrix} a_{11} + ka_{21} & a_{12} + ka_{22} & a_{13} + ka_{23} \\ a_{21} & a_{22} & a_{23} \\ a_{31} & a_{32} & a_{33} \end{bmatrix}$$

$$\begin{aligned}
 |B| &= \begin{vmatrix} a_{11} + ka_{21} & a_{12} + ka_{22} & a_{13} + ka_{23} \\ a_{21} & a_{22} & a_{23} \\ a_{31} & a_{32} & a_{33} \end{vmatrix} \\
 &= \begin{vmatrix} a_{11} & a_{12} & a_{13} \\ a_{21} & a_{22} & a_{23} \\ a_{31} & a_{32} & a_{33} \end{vmatrix} + \begin{vmatrix} ka_{21} & ka_{22} & ka_{23} \\ a_{21} & a_{22} & a_{23} \\ a_{31} & a_{32} & a_{33} \end{vmatrix} \\
 &= |A| + k \begin{vmatrix} a_{21} & a_{22} & a_{33} \\ a_{21} & a_{22} & a_{23} \\ a_{31} & a_{32} & a_{33} \end{vmatrix} = |A| + k(0) \\
 \therefore |B| &= |A|
 \end{aligned}$$

$\because R_1$ and R_2 are identical.

Example: Consider the matrix $A = \begin{bmatrix} 3 & 2 & 0 \\ 1 & 4 & -1 \\ 3 & -1 & 2 \end{bmatrix}$ then

$$\begin{aligned}
 |A| &= \begin{vmatrix} 3 & 2 & 0 \\ 1 & 4 & -1 \\ 3 & -1 & 2 \end{vmatrix} \\
 &= 3 \begin{vmatrix} 4 & -1 \\ -1 & 2 \end{vmatrix} - 2 \begin{vmatrix} 1 & -1 \\ 3 & 2 \end{vmatrix} + 0 \begin{vmatrix} 1 & 4 \\ 3 & -1 \end{vmatrix} \\
 &= 3(8 - 1) - 2(2 + 3) + 0(-1 - 12) = 21 - 10 + 0 = 11
 \end{aligned}$$

Let we multiply R_1 By 2 and adding values to the corresponding elements of R_3 ; the resulting matrix is

$$B = \begin{bmatrix} 3 & 2 & 0 \\ 1 & 4 & -1 \\ 9 & 3 & 2 \end{bmatrix}$$

Now

$$\begin{aligned}
 |B| &= \begin{vmatrix} 3 & 2 & 0 \\ 1 & 4 & -1 \\ 9 & 3 & 2 \end{vmatrix} = 3 \begin{vmatrix} 4 & -1 \\ 3 & 2 \end{vmatrix} - 2 \begin{vmatrix} 1 & -1 \\ 9 & 2 \end{vmatrix} + 0 \begin{vmatrix} 1 & 4 \\ 9 & 3 \end{vmatrix} \\
 &= 3(8 + 3) - 2(2 + 9) + 0(3 - 36) = 33 - 22 + 0 = 11
 \end{aligned}$$

We conclude that $|A| = |B|$

Property 8:

If a square matrix A is upper triangular or lower triangular or diagonal matrix then $|A|$ is the product of its diagonal elements.

Proof:

$$\text{Let } A = \begin{bmatrix} a_{11} & a_{12} & a_{13} \\ 0 & a_{22} & a_{23} \\ 0 & 0 & a_{33} \end{bmatrix}$$

$$|A| = \begin{vmatrix} a_{11} & a_{12} & a_{13} \\ 0 & a_{22} & a_{23} \\ 0 & 0 & a_{33} \end{vmatrix}$$

Expanding by C_1

$$\begin{aligned}
 &= a_{11} \begin{vmatrix} a_{22} & a_{23} \\ 0 & a_{33} \end{vmatrix} - 0 + 0 = a_{11}(a_{22}a_{33} - 0) \\
 &= a_{11}a_{22}a_{33} = \text{product of the diagonal elements}
 \end{aligned}$$

Example: If $A = \begin{bmatrix} 3 & 0 & 0 \\ 2 & 1 & 0 \\ 4 & 3 & 2 \end{bmatrix}$ then

$$\begin{aligned} |A| &= \begin{vmatrix} 3 & 0 & 0 \\ 2 & 1 & 0 \\ 4 & 3 & 2 \end{vmatrix} \\ &= 3 \begin{vmatrix} 1 & 0 \\ 3 & 2 \end{vmatrix} - 0 + 0 = 3(2 - 0) = 6 \\ &= (3)(2)(1) = \text{product of diagonal elements} \end{aligned}$$

2.4.2 Evaluation of Determinants Without Expansion

Example: Without expansion show that $\begin{vmatrix} a-2l & b-2m & c-2n \\ l & m & n \\ a & b & c \end{vmatrix} = 0$

Solution: L.H.S

$$\begin{aligned} \begin{vmatrix} a-2l & b-2m & c-2n \\ l & m & n \\ a & b & c \end{vmatrix} &= \begin{vmatrix} a & b & c \\ l & m & n \\ a & b & c \end{vmatrix} + \begin{vmatrix} -2l & -2m & -2n \\ l & m & n \\ a & b & c \end{vmatrix} \\ &= \begin{vmatrix} a & b & c \\ l & m & n \\ a & b & c \end{vmatrix} - 2 \begin{vmatrix} l & m & n \\ l & m & n \\ a & b & c \end{vmatrix} \\ &= 0 - 2(0) = 0 \end{aligned}$$

Example: If $a + b + c = 0$; then without expanding show that

$$\begin{vmatrix} b+c & c+a & a+b \\ c+a & a+b & b+c \\ a+b & b+c & c+a \end{vmatrix} = 0$$

Solution: L.H.S = $\begin{vmatrix} b+c & c+a & a+b \\ c+a & a+b & b+c \\ a+b & b+c & c+a \end{vmatrix}$

$$= \begin{vmatrix} 2a+2b+2c & 2a+2b+2c & 2a+2b+2c \\ c+a & a+b & b+c \\ a+b & b+c & c+a \end{vmatrix} \text{ by } R_1 + (R_2 + R_3)$$

$$= \begin{vmatrix} 2(a+b+c) & 2(a+b+c) & 2(a+b+c) \\ c+a & a+b & b+c \\ a+b & b+c & c+a \end{vmatrix}$$

$$= \begin{vmatrix} 2(0) & 2(0) & 2(0) \\ c+a & a+b & b+c \\ a+b & b+c & c+a \end{vmatrix} = \begin{vmatrix} 0 & 0 & 0 \\ c+a & a+b & b+c \\ a+b & b+c & c+a \end{vmatrix} = 0$$

Example: Prove that $\begin{vmatrix} a^2+1 & ab & ac \\ ab & b^2+1 & bc \\ ac & bc & c^2+1 \end{vmatrix} = 1 + a^2 + b^2 + c^2$

Solution:

$$\begin{vmatrix} a^2 + 1 & ab & ac \\ ab & b^2 + 1 & bc \\ ac & bc & c^2 + 1 \end{vmatrix} = \begin{vmatrix} a^2 \left(1 + \frac{1}{a^2}\right) & ab & ac \\ ab & b^2 \left(1 + \frac{1}{b^2}\right) & bc \\ ac & bc & c^2 \left(1 + \frac{1}{c^2}\right) \end{vmatrix}$$

$$= abc \begin{vmatrix} a \left(1 + \frac{1}{a^2}\right) & b & c \\ a & b \left(1 + \frac{1}{b^2}\right) & c \\ a & b & c \left(1 + \frac{1}{c^2}\right) \end{vmatrix}$$

Taking out common
a from R_1 , b from R_2
and c from R_3 .

$$= a^2 b^2 c^2 \begin{vmatrix} \left(1 + \frac{1}{a^2}\right) & 1 & 1 \\ 1 & \left(1 + \frac{1}{b^2}\right) & 1 \\ 1 & 1 & \left(1 + \frac{1}{c^2}\right) \end{vmatrix}$$

Taking out common
a from C_1 , b from C_2
and c from C_3 .

$$= a^2 b^2 c^2 \begin{vmatrix} \frac{1}{a^2} & 0 & 1 \\ 0 & \frac{1}{b^2} & 1 \\ -\frac{1}{c^2} & -\frac{1}{c^2} & 1 + \frac{1}{c^2} \end{vmatrix}$$

By $C_1 - C_3$
 $C_2 - C_3$

Expanding from R_1

$$= a^2 b^2 c^2 \left(\frac{1}{a^2} \begin{vmatrix} \frac{1}{b^2} & 1 \\ -\frac{1}{c^2} & 1 + \frac{1}{c^2} \end{vmatrix} - 0 \begin{vmatrix} 0 & 1 \\ -\frac{1}{c^2} & 1 + \frac{1}{c^2} \end{vmatrix} + 1 \begin{vmatrix} 0 & \frac{1}{b^2} \\ -\frac{1}{c^2} & -\frac{1}{c^2} \end{vmatrix} \right)$$

$$= a^2 b^2 c^2 \left[\frac{1}{a^2} \left\{ \frac{1}{b^2} \left(1 + \frac{1}{c^2}\right) + \frac{1}{c^2} \right\} - 0 + 1 \left(0 + \frac{1}{b^2 c^2}\right) \right]$$

$$= a^2 b^2 c^2 \left(\frac{1}{a^2 b^2} + \frac{1}{a^2 b^2 c^2} + \frac{1}{a^2 c^2} + \frac{1}{b^2 c^2} \right)$$

$$= c^2 + 1 + b^2 + a^2 = 1 + a^2 + b^2 + c^2$$

Example: Prove that $\begin{vmatrix} 1 & a^2 & a \\ a & 1 & a^2 \\ a^2 & a & 1 \end{vmatrix} = (1 - a^3)^2$

Solution:

$$\begin{vmatrix} 1 & a^2 & a \\ a & 1 & a^2 \\ a^2 & a & 1 \end{vmatrix} = \begin{vmatrix} 1 + a + a^2 & 1 + a + a^2 & 1 + a + a^2 \\ a & 1 & a^2 \\ a^2 & a & 1 \end{vmatrix}$$

By $R_1 + (R_2 + R_3)$

$$= (1 + a + a^2) \begin{vmatrix} 1 & 1 & 1 \\ a & 1 & a^2 \\ a^2 & a & 1 \end{vmatrix} \quad \text{Taking out common from } R_1$$

$$= (1 + a + a^2) \begin{vmatrix} 1 & 0 & 0 \\ a & 1 - a & a^2 - a \\ a^2 & a - a^2 & 1 - a^2 \end{vmatrix} \quad \begin{array}{l} \text{By } C_2 - C_1 \\ C_3 - C_1 \end{array}$$

Expanding from R_1

$$= (1 + a + a^2) (1 \begin{vmatrix} 1 - a & a^2 - a \\ a - a^2 & 1 - a^2 \end{vmatrix} - 0 + 0)$$

$$= (1 + a + a^2) \begin{vmatrix} 1 - a & a^2 - a \\ a - a^2 & 1 - a^2 \end{vmatrix}$$

$$= (1 + a + a^2)(1 - a)(1 - a) \begin{vmatrix} 1 & -a \\ a & 1 + a \end{vmatrix}$$

$$= (1 + a + a^2)(1 - a)(1 - a)(1 + a + a^2)$$

$$= (1 - a^3)(1 - a^3) = (1 - a^3)^2$$

Taking out common from C_1 , and C_2

Exercise 2.4

1. Without expansion show that:

(i) $\begin{vmatrix} 9 & 27 & 36 \\ 18 & 54 & 24 \\ 27 & 81 & 28 \end{vmatrix} = 0$ (ii) $\begin{vmatrix} 1/a & bc & b + c \\ 1/b & ac & a + c \\ 1/c & ab & a + b \end{vmatrix} = 0$ (iii) $\begin{vmatrix} 0 & -a & -b \\ a & 0 & -c \\ b & c & 0 \end{vmatrix} = 0$

(iv) $\begin{vmatrix} \sin^2 \alpha & 1 & \cos^2 \alpha \\ \tan^2 \alpha & \sec^2 \alpha & 1 \\ -\operatorname{cosec}^2 \alpha & -\cot^2 \alpha & 1 \end{vmatrix} = 0$ (v) $\begin{vmatrix} (a - b)^3 & a^3 - b^3 & ab(a - b) \\ (c - d)^3 & c^3 - d^3 & cd(c - d) \\ (e - f)^3 & e^3 - f^3 & ef(e - f) \end{vmatrix} = 0$

(vi) $\begin{vmatrix} x & -z & 0 \\ 0 & y & -x \\ -y & 0 & z \end{vmatrix} = 0$ (vii) $\begin{vmatrix} (a - b)^2 & (a + b)^2 & ab \\ (c - d)^2 & (c + d)^2 & cd \\ (e - f)^2 & (e + f)^2 & ef \end{vmatrix} = 0$

2. Using the properties of the determinants prove the following.

(i) $\begin{vmatrix} x & y & x + y \\ y & x + y & x \\ x + y & x & y \end{vmatrix} = -2(x^3 + y^3)$

(ii) $\begin{vmatrix} a & b - c & b + c \\ a + c & b & c - a \\ a - b & a + b & c \end{vmatrix} = (a + b + c)(a^2 + b^2 + c^2)$

(iii) $\begin{vmatrix} na_1 + b_1 & na_2 + b_2 & na_3 + b_3 \\ nb_1 + c_1 & nb_2 + c_2 & nb_3 + c_3 \\ nc_1 + a_1 & nc_2 + a_2 & nc_3 + a_3 \end{vmatrix} = (n^3 + 1) \begin{vmatrix} a_1 & a_2 & a_3 \\ b_1 & b_2 & b_3 \\ c_1 & c_2 & c_3 \end{vmatrix}$

(iv) $\begin{vmatrix} x & x^2 & 1 + ax^3 \\ y & y^2 & 1 + ay^3 \\ z & z^2 & 1 + az^3 \end{vmatrix} = (1 + axyz)(x - y)(y - z)(z - x)$

- (v)
$$\begin{vmatrix} 2ab & 1 + a^2 - b^2 & 2b \\ 2a & -2b & 1 - a^2 - b^2 \\ 1 - a^2 + b^2 & 2ab & -2a \end{vmatrix} = (1 + a^2 + b^2)^3$$
- (vi)
$$\begin{vmatrix} 3a & 1 & 2a + 1 \\ 2a + 1 & 1 & a + 2 \\ 3 & 1 & 2 \end{vmatrix} = (a - 1)(a - 2)$$
- (vii)
$$\begin{vmatrix} b + c & a & a \\ b & c + a & b \\ c & c & a + b \end{vmatrix} = 4abc$$
- (viii)
$$\begin{vmatrix} -bc & b^2 + bc & c^2 + bc \\ a^2 + ac & -ac & c^2 + ac \\ a^2 + ab & b^2 + ab & -ab \end{vmatrix} = (ab + bc + ca)^2$$
- (ix)
$$\begin{vmatrix} (b + c)^2 & ab & ca \\ ab & (a + c)^2 & bc \\ ac & bc & (a + b)^2 \end{vmatrix} = 2abc(a + b + c)^3$$
- (x)
$$\begin{vmatrix} b + c & q + r & y + z \\ c + a & r + p & z + x \\ a + b & p + q & x + y \end{vmatrix} = 2 \begin{vmatrix} a & p & x \\ b & q & y \\ c & r & z \end{vmatrix}$$
- (xi) If $|AB| = |A| \cdot |B|$ and $|A^{-1}| = 1/|A|$ then for a square matrix of order 3×3 prove that $|\text{adj}A| = |A|^2$
- (xii) If A is of order 3×3 such that $|\text{adj}A| = 64$ then find $|A^{-1}|$.
- (xiii) If a, b, c are real numbers and $\begin{vmatrix} b + c & c + a & a + b \\ c + a & a + b & b + c \\ a + b & b + c & c + a \end{vmatrix} = 0$. Show that either $a + b + c = 0$ or $a = b = c$.

2.5. Rows and Columns Operations

2.5.1 Rows and Columns Operations on Matrices

Elementary Row Operations

The following elementary row operations can be performed on a matrix.

- (i) We can interchange any two rows of the matrix. If we interchange the i th row with the j th row of the matrix then it is denoted by R_{ij} .
- (ii) We can multiply any row by a non-zero scalar k with the i th row then it is denoted by kR_i .
- (iii) We can add a multiple of any row to the corresponding values of any other row. If we add k -times of the j th row to the i th row then it is denoted by $R_i + kR_j$.

Elementary Column Operations

The following elementary column operations can be performed on a matrix.

- (i) We can interchange any two columns of the matrix. If we interchange the i th column with the j th column of the matrix then it is denoted by C_{ij} .

- (ii) We can multiply any column by a non-zero scalar k with the i th column then it is denoted by kC_i .
- (iii) We can add a multiple of any other column to the corresponding values of any other column. If we add k -times of the j th column to the i th column then it is denoted by $C_i + kC_j$.

2.5.2 Echelon Form of a Matrix

Any matrix which has the following properties is known as in Echelon form (row Echelon form).

- (i) If a row does not consist entirely of zeros, then the first non-zero number in the row is 1; we call this leading 1.
- (ii) If there are many rows that consist entirely of zeros, then they are grouped together at the bottom of the matrix.
- (iii) In any two successive rows that do not consist entirely of zeros, the leading 1 in the lower row occurs farther to the right than the leading 1 in the higher row.
- (iv) Each column that contains a leading 1 has zeros below 1.

2.5.3 Reduced Echelon Form of a Matrix

Any matrix which has the following properties is known as in Reduced Echelon form.

- (i) If a row does not consist entirely of zeros, then the first non-zero number in the row is 1; we call this leading 1.
- (ii) If there are many rows that consist entirely of zeros, then they are grouped together at the bottom of the matrix.
- (iii) In any two successive rows that do not consist entirely of zeros, the leading 1 in the lower row occurs farther to the right than the leading 1 in the higher row.
- (iv) Each column that contains a leading 1 has zero everywhere else in that column.

Example: Reduce the matrix $A = \begin{bmatrix} 3 & 1 & 2 \\ -2 & 4 & 1 \\ 1 & 0 & 2 \end{bmatrix}$ into the echelon form.

Solution: $A = \begin{bmatrix} 3 & 1 & 2 \\ -2 & 4 & 1 \\ 1 & 0 & 2 \end{bmatrix}$

$$\sim R \begin{bmatrix} 1 & 0 & 2 \\ -2 & 4 & 1 \\ 3 & 1 & 2 \end{bmatrix} \quad \text{by } R_{13}$$

$$\sim R \begin{bmatrix} 1 & 0 & 2 \\ 0 & 4 & 5 \\ 0 & 1 & -4 \end{bmatrix} \quad \begin{array}{l} \text{by } R_2 + 2R_1 \\ R_3 - 3R_1 \end{array}$$

$$\sim R \begin{bmatrix} 1 & 0 & 2 \\ 0 & 1 & -4 \\ 0 & 4 & 5 \end{bmatrix} \quad \text{by } R_{23}$$

Key Facts



A matrix in reduced echelon form is also in echelon form; but a matrix in echelon form may not be in reduced echelon form.

$$\sim R \begin{bmatrix} 1 & 0 & 2 \\ 0 & 1 & -4 \\ 0 & 0 & 21 \end{bmatrix} \quad \text{by } R_3 - 4R_2$$

$$\sim R \begin{bmatrix} 1 & 0 & 2 \\ 0 & 1 & -4 \\ 0 & 0 & 1 \end{bmatrix} \quad \text{by } \frac{1}{21}R_3$$

Which is the required echelon form of matrix A .

Example: Write the matrix $A = \begin{bmatrix} 1 & 2 & 3 & 4 \\ 2 & 3 & 4 & 5 \\ 4 & 5 & 6 & 7 \end{bmatrix}$ into the reduced echelon form.

Solution: $A = \begin{bmatrix} 1 & 2 & 3 & 4 \\ 2 & 3 & 4 & 5 \\ 4 & 5 & 6 & 7 \end{bmatrix}$

$$\sim R \begin{bmatrix} 1 & 2 & 3 & 4 \\ 0 & -1 & -2 & -3 \\ 0 & -3 & -6 & -9 \end{bmatrix} \quad \begin{array}{l} \text{by } R_2 - 2R_1 \\ R_3 - 4R_1 \end{array}$$

$$\sim R \begin{bmatrix} 1 & 2 & 3 & 4 \\ 0 & 1 & 2 & 3 \\ 0 & 1 & 2 & 3 \end{bmatrix} \quad \text{by } -R_2 \text{ and } -\frac{1}{3}R_3$$

$$\sim R \begin{bmatrix} 1 & 0 & -1 & -2 \\ 0 & 1 & 2 & 3 \\ 0 & 0 & 0 & 0 \end{bmatrix} \quad \begin{array}{l} \text{by } R_1 - 2R_2 \\ R_3 - R_2 \end{array}$$

Which is the reduced echelon form.

2.5.4 Rank of a Matrix

Using Row Operations to Find the Rank of a Matrix

To find the rank of a matrix, find its echelon (or reduced echelon) form. The number of non-zero rows in its echelon form is called the rank (or row rank) of the matrix.

Example: Find the rank of the matrix $\begin{bmatrix} 2 & 5 & 7 \\ 1 & 2 & -1 \\ -3 & -6 & 3 \end{bmatrix}$.

Solution: Let $A = \begin{bmatrix} 2 & 5 & 7 \\ 1 & 2 & -1 \\ -3 & -6 & 3 \end{bmatrix}$

$$\sim R \begin{bmatrix} 1 & 2 & -1 \\ 2 & 5 & 7 \\ -3 & -6 & 3 \end{bmatrix} \quad \text{by } R_{12}$$

$$\sim R \begin{bmatrix} 1 & 2 & -1 \\ 0 & 1 & 9 \\ 0 & 0 & 0 \end{bmatrix} \quad \begin{array}{l} \text{by } R_2 - 2R_1 \\ R_3 + 3R_1 \end{array}$$

Which is the echelon form of the matrix. The number of non-zero rows is 2.

Thus Rank(A) = 2

2.5.5 Using Row Operation to Find the Inverse of a Non-Singular Matrix

Row operations can be performed on a non-singular matrix A to find its inverse. For this consider an identity matrix I of same order as that of A . Write A and I parallel to each other. Now perform some row operations on A and I so that matrix A reduce to I , consequently the matrix I will also reduce to some new matrix which is the inverse of A .

We can also perform column operations to find A^{-1} .

Example: Find A^{-1} ; if $A = \begin{bmatrix} 2 & 1 & 0 \\ 4 & 3 & 1 \\ 1 & 0 & 2 \end{bmatrix}$ by using row operations.

Solution: $|A| = \begin{vmatrix} 2 & 1 & 0 \\ 4 & 3 & 1 \\ 1 & 0 & 2 \end{vmatrix}$

$$= 2 \begin{vmatrix} 3 & 1 \\ 0 & 2 \end{vmatrix} - 1 \begin{vmatrix} 4 & 1 \\ 1 & 2 \end{vmatrix} + 0 \begin{vmatrix} 4 & 3 \\ 1 & 0 \end{vmatrix}$$

$$= 2(6 - 0) - 1(8 - 1) + 0(0 - 3)$$

$$= 12 - 7 + 0 = 5 \neq 0$$

So A is non singular. Now consider

$$[A|I] = \begin{bmatrix} 2 & 1 & 0 & : & 1 & 0 & 0 \\ 4 & 3 & 1 & : & 0 & 1 & 0 \\ 1 & 0 & 2 & : & 0 & 0 & 1 \end{bmatrix}$$

$$\sim R \begin{bmatrix} 1 & 0 & 2 & : & 0 & 0 & 1 \\ 4 & 3 & 1 & : & 0 & 1 & 0 \\ 2 & 1 & 0 & : & 1 & 0 & 0 \end{bmatrix} \quad \text{by } R_{13}$$

$$\sim R \begin{bmatrix} 1 & 0 & 2 & : & 0 & 0 & 1 \\ 0 & 3 & -7 & : & 0 & 1 & -4 \\ 0 & 1 & -4 & : & 1 & 0 & -2 \end{bmatrix} \quad \begin{array}{l} \text{by } R_2 - 4R_1 \\ R_3 - 2R_1 \end{array}$$

$$\sim R \begin{bmatrix} 1 & 0 & 2 & : & 0 & 0 & 1 \\ 0 & 1 & -4 & : & 1 & 0 & -2 \\ 0 & 3 & -7 & : & 0 & 1 & -4 \end{bmatrix} \quad \text{by } R_{23}$$

$$\sim R \begin{bmatrix} 1 & 0 & 2 & : & 0 & 0 & 1 \\ 0 & 1 & -4 & : & 1 & 0 & -2 \\ 0 & 0 & 5 & : & -3 & 1 & 2 \end{bmatrix} \quad \text{by } R_3 - 3R_2$$

$$\sim R \begin{bmatrix} 1 & 0 & 2 & : & 0 & 0 & 1 \\ 0 & 1 & -4 & : & 1 & 0 & -2 \\ 0 & 0 & 1 & : & -3/5 & 1/5 & 2/5 \end{bmatrix} \quad \text{by } \frac{1}{5}R_3$$

$$\sim R \begin{bmatrix} 1 & 0 & 0 & : & 6/5 & -2/5 & 1/5 \\ 0 & 1 & 0 & : & -7/5 & 4/5 & -2/5 \\ 0 & 0 & 1 & : & -3/5 & 1/5 & 2/5 \end{bmatrix}$$

Thus $A^{-1} = \begin{bmatrix} 6/5 & -2/5 & 1/5 \\ -7/5 & 4/5 & -2/5 \\ -3/5 & 1/5 & 2/5 \end{bmatrix}$

Exercise 2.5

1. First reduce each of the following matrices into echelon form then into reduced echelon form.

(i) $\begin{bmatrix} 1 & 3 & 5 \\ -6 & 8 & 3 \\ -4 & 6 & 5 \end{bmatrix}$

(ii) $\begin{bmatrix} 2 & 1 \\ 3 & 2 \\ 1 & 9 \end{bmatrix}$

(iii) $\begin{bmatrix} 2 & -1 & 0 \\ 4 & 7 & 8 \\ -3 & 1 & 3 \end{bmatrix}$

(iv) $\begin{bmatrix} 2 & -4 & 3 \\ 4 & 1 & 8 \\ 7 & 3 & 0 \end{bmatrix}$

(v) $\begin{bmatrix} 3 & 1 & 2 \\ 2 & 9 & 8 \end{bmatrix}$

(vi) $\begin{bmatrix} 0 & 2 & 4 \\ 0 & 3 & 6 \\ 0 & 1 & 2 \end{bmatrix}$

2. Find the rank of each of the following matrices.

(i) $\begin{bmatrix} 5 & 9 & 3 \\ 3 & -5 & 6 \\ 2 & 10 & 6 \end{bmatrix}$

(ii) $\begin{bmatrix} -1 & -2 & 3 \\ -1 & 2 & -1 \\ -5 & 2 & 3 \end{bmatrix}$

(iii) $\begin{bmatrix} 3 & 2 & 4 \\ 2 & 1 & 6 \\ 4 & -1 & 0 \end{bmatrix}$

(iv) $\begin{bmatrix} 1 & 3 \\ 2 & 9 \\ 1 & 6 \end{bmatrix}$

3. With the help of row operations, find the inverse of the following matrices if it exists.

Also verify your answer by showing that $AA^{-1} = A^{-1}A = I$.

(i) $\begin{bmatrix} 0 & -1 & -1 \\ -1 & 3 & 0 \\ 1 & -1 & 4 \end{bmatrix}$

(ii) $\begin{bmatrix} 1 & 2 & 5 \\ -3 & 0 & 1 \\ 4 & 2 & 5 \end{bmatrix}$

(iii) $\begin{bmatrix} -5 & 2 & 3 \\ -1 & -2 & 3 \\ 1 & -2 & 3 \end{bmatrix}$

(iv) $\begin{bmatrix} 0 & 1 & 3 \\ 3 & 2 & 4 \\ 6 & -1 & 2 \end{bmatrix}$

2.6 Solving System of Linear Equations

Linear Equation

An equation of the form $a_1x_1 + a_2x_2 = k_1$; where a_1, a_2 and k_1 are constants and at least one of a_1 and a_2 is non-zero is called a linear equation in two variables x_1 and x_2 .

Similarly, the equation of the form $a_1x_1 + a_2x_2 + a_3x_3 = k_2$; where a_1, a_2, a_3 and k_2 are constants and at least one of a_1, a_2 and a_3 is non-zero is called a linear equation in three variables x_1, x_2 and x_3 . In the same manner we can extend this for n number of variables.

System of Linear Equations

When we deal with more than one linear equation at the same time; then it is called system of linear equations. We divide the system of linear equations into two categories:

- (i) Homogeneous system of linear equations.
- (ii) Non-homogeneous system of linear equations.

2.6.1 Homogeneous and Non-homogeneous Linear Equations

Homogeneous System of Linear Equations

Consider the following system of linear equations

$$a_1x + b_1y + c_1z = k_1$$

$$a_2x + b_2y + c_2z = k_2$$

$$a_3x + b_3y + c_3z = k_3$$

If $k_1 = k_2 = k_3 = 0$; then the system is called homogeneous system of linear equations.

Non-Homogeneous System of Linear Equations

For the following system of linear equations

$$a_1x + b_1y + c_1z = k_1$$

$$a_2x + b_2y + c_2z = k_2$$

$$a_3x + b_3y + c_3z = k_3$$

If at least one of k_1, k_2 and k_3 is non-zero then the system is called non-homogeneous system of equations.

2.6.2 Solution of System of Linear Equations

The values of the variables involved in the system of linear equations which when substituted in any equation of the system the equation is satisfied; is known as the solution of the system.

A system may have no solution or unique solution or infinite number of solutions.

Solution of Homogeneous System of Linear Equations

Consider a system of homogeneous equations

$$a_1x + b_1y + c_1z = 0$$

$$a_2x + b_2y + c_2z = 0$$

$$a_3x + b_3y + c_3z = 0$$

This system may be written as

$$\begin{bmatrix} a_1 & b_1 & c_1 \\ a_2 & b_2 & c_2 \\ a_3 & b_3 & c_3 \end{bmatrix} \begin{bmatrix} x \\ y \\ z \end{bmatrix} = \begin{bmatrix} 0 \\ 0 \\ 0 \end{bmatrix}$$

$$\text{Let } A = \begin{bmatrix} a_1 & b_1 & c_1 \\ a_2 & b_2 & c_2 \\ a_3 & b_3 & c_3 \end{bmatrix}; \quad X = \begin{bmatrix} x \\ y \\ z \end{bmatrix}; \quad O = \begin{bmatrix} 0 \\ 0 \\ 0 \end{bmatrix} \tag{1}$$

So, we write $AX = O$

Observe that each equation of the system is satisfied if we take $x = 0; y = 0; z = 0$. So, $(0, 0, 0)$ is the solution of the homogeneous system of linear equations. Since this solution always exists for all systems of the homogeneous equations thus it is called trivial solutions of the system. All solutions other than trivial solution are known as non-trivial solutions of the system.

Observe that, if the coefficients matrix A is non-singular then A^{-1} exists; so

$$\begin{aligned} (1) &\Rightarrow A^{-1}(AX) = A^{-1}(O) \\ &\Rightarrow (A^{-1}A)X = O \\ &\Rightarrow IX = O \\ &\Rightarrow X = O \end{aligned}$$

Key Facts

Condition for the system of homogeneous linear equations to have non-trivial solution is that $|A| = 0$.



$$\Rightarrow \begin{bmatrix} x \\ y \\ z \end{bmatrix} = \begin{bmatrix} 0 \\ 0 \\ 0 \end{bmatrix}$$

$$\Rightarrow x = 0, y = 0, z = 0$$

i.e.; The system has a trivial solution.

The system of homogeneous linear equations may have non-trivial solution if $|A| = 0$.

Example: How many solutions does the following system of homogeneous linear equations has?

$$3x - 2y + z = 0 \tag{1}$$

$$2x + y - 3z = 0 \tag{2}$$

$$x - y + z = 0 \tag{3}$$

Solution:

The coefficients matrix is:

$$A = \begin{bmatrix} 3 & -2 & 1 \\ 2 & 1 & -3 \\ 1 & -1 & 1 \end{bmatrix}$$

$$\begin{aligned} |A| &= 3 \begin{vmatrix} 1 & -3 \\ -1 & 1 \end{vmatrix} - (-2) \begin{vmatrix} 2 & -3 \\ 1 & 1 \end{vmatrix} + 1 \begin{vmatrix} 2 & 1 \\ 1 & -1 \end{vmatrix} \\ &= 3(1 - 3) + 2(2 + 3) + 1(-2 - 1) \\ &= -6 + 10 - 3 = 1 \neq 0 \end{aligned}$$

This system has only trivial solution.

Example: Solve the homogeneous system of linear equations:

$$x + 3y + 2z = 0 \tag{1}$$

$$2x - y + 3z = 0 \tag{2}$$

$$x - 4y + z = 0 \tag{3}$$

Solution:

The coefficients matrix is:

$$A = \begin{bmatrix} 1 & 3 & 2 \\ 2 & -1 & 3 \\ 1 & -4 & 1 \end{bmatrix}$$

$$|A| = 1 \begin{vmatrix} -1 & 3 \\ -4 & 1 \end{vmatrix} - 3 \begin{vmatrix} 2 & 3 \\ 1 & 1 \end{vmatrix} + 2 \begin{vmatrix} 2 & -1 \\ 1 & -4 \end{vmatrix}$$

$$|A| = 1(-1 + 12) - 3(2 - 3) + 2(-8 + 1)$$

$$|A| = 11 + 3 - 14 = 0$$

So the system has non-trivial solution.

Multiplying equation (1) by 2 then subtracting equation (2) from it, we get:

$$(1) \Rightarrow 2x + 6y + 4z = 0$$

$$(2) \Rightarrow 2x - y + 3z = 0$$

$$\begin{array}{r} - \quad + \quad - \\ \hline \end{array}$$

$$7y + z = 0 \tag{4}$$

(4)

Subtracting equation (3) from equation (1), we have:

$$\begin{array}{r}
 (1) \Rightarrow x + 3y + 2z = 0 \\
 (3) \Rightarrow x - 4y + z = 0 \\
 \hline
 - + - = 0 \\
 + 7y + z = 0
 \end{array} \tag{5}$$

Now equations (4) and (5) are identical

Put $z = t$ in equation (4).

$$\Rightarrow 7y + t = 0 \Rightarrow 7y = -t \Rightarrow y = -\frac{1}{7}t$$

Substituting these values in equation (1), we have:

$$\begin{aligned}
 x + 3\left(-\frac{1}{7}t\right) + 2t &= 0 \\
 \Rightarrow x - \frac{3}{7}t + 2t &= 0 \Rightarrow x + \frac{11}{7}t = 0 \\
 \Rightarrow x &= -\frac{11}{7}t
 \end{aligned}$$

Thus $\left(-\frac{11}{7}t, -\frac{1}{7}t, t\right)$ are the infinite many solutions. By assigning different values to t we will have different solutions.

Consistent System of Equations

A system of linear equations which has at least one solution is called consistent system of equations.

In-consistent System of Equations

A system of linear equations which has no solution at all is called in-consistent system of equations.

2.6.3 Solution of Non-Homogeneous System of Linear Equations

Consider a non-homogeneous system of linear equations:

$$a_1x + b_1y + c_1z = k_1$$

$$a_2x + b_2y + c_2z = k_2$$

$$a_3x + b_3y + c_3z = k_3$$

where, at least one of k_1, k_2 and k_3 is non-zero.

The above system in matrix form may be written as

$$\begin{bmatrix} a_1 & b_1 & c_1 \\ a_2 & b_2 & c_2 \\ a_3 & b_3 & c_3 \end{bmatrix} \begin{bmatrix} x \\ y \\ z \end{bmatrix} = \begin{bmatrix} k_1 \\ k_2 \\ k_3 \end{bmatrix}$$

Let $A = \begin{bmatrix} a_1 & b_1 & c_1 \\ a_2 & b_2 & c_2 \\ a_3 & b_3 & c_3 \end{bmatrix}; \quad X = \begin{bmatrix} x \\ y \\ z \end{bmatrix}; \quad B = \begin{bmatrix} k_1 \\ k_2 \\ k_3 \end{bmatrix}$

$$\Rightarrow AX = B$$

Remember



System of homogeneous linear equations is always consistent since it has at least trivial solution.

Consistency Criteria

A system of homogeneous linear equations is consistent if $Rank A = Rank A_b$. The system is inconsistent if $Rank A \neq Rank A_b$.

If $Rank A = Rank A_b =$ number of unknowns, then the system has a unique solution.

If $Rank A = Rank A_b <$ number of unknowns, then system has infinite many solutions.

Augmented Matrix

For a given system of linear equations, a matrix consisting of the coefficients of the unknowns together with the constants on the right side of equations is called an augmented matrix. It is usually denoted by A_b . For the above system of linear equations the augmented matrix is:

$$A_b = \begin{bmatrix} a_1 & b_1 & c_1 & : & k_1 \\ a_2 & b_2 & c_2 & : & k_2 \\ a_3 & b_3 & c_3 & : & k_3 \end{bmatrix}$$

Methods to Solve a Non-Homogeneous System of Equations

To solve a system of 3 - by - 3 non-homogeneous system of linear equations, we use the following methods.

- Matrix inversion method
- Gauss elimination method (echelon form)
- Gauss Jordan method (reduced echelon form)
- Cramer's rule

Matrix Inversion Method

Consider the non-homogeneous system of linear equations:

$$a_1x + b_1y + c_1z = k_1$$

$$a_2x + b_2y + c_2z = k_2$$

$$a_3x + b_3y + c_3z = k_3$$

In matrix form this system may be written as:

$$AX = B$$

If A is invertible (i.e.; non-singular) then A^{-1} exists; so

$$A^{-1}(AX) = A^{-1}B$$

$$\Rightarrow (A^{-1}A)X = A^{-1}B$$

$$\Rightarrow IX = A^{-1}B$$

$$\Rightarrow X = A^{-1}B$$

Example: Solve the system of non-homogeneous linear equation by matrix inversion method.

$$2x + 3y - z = 1; \quad x - y + z = 3; \quad x + 2y - z = 1$$

Solution:

For this system of equations; we have

$$A = \begin{bmatrix} 2 & 3 & -1 \\ 1 & -1 & 1 \\ 1 & 2 & -1 \end{bmatrix}; \quad X = \begin{bmatrix} x \\ y \\ z \end{bmatrix}; \quad B = \begin{bmatrix} 1 \\ 3 \\ 1 \end{bmatrix}$$

$$\text{and } |A| = \begin{vmatrix} 2 & 3 & -1 \\ 1 & - & 1 \\ 1 & 2 & -1 \end{vmatrix} = 2 \begin{vmatrix} -1 & 1 \\ 2 & -1 \end{vmatrix} - 3 \begin{vmatrix} 1 & 1 \\ 1 & -1 \end{vmatrix} - 1 \begin{vmatrix} 1 & -1 \\ 1 & 2 \end{vmatrix}$$

$$= 2(1 - 2) - 3(-1 - 1) - 1(2 + 1) = -2 + 6 - 3 = 1 \neq 0$$

This system is consistent. Now to find A^{-1} , we calculate the cofactors of each element .

$$A_{11} = (-1)^{1+1} \begin{vmatrix} -1 & 1 \\ 2 & -1 \end{vmatrix} = (-1)^2(1 - 2) = -1$$

$$A_{12} = (-1)^{1+2} \begin{vmatrix} 1 & 1 \\ 1 & -1 \end{vmatrix} = (-1)^3(-1 - 1) = 2$$

$$A_{13} = (-1)^{1+3} \begin{vmatrix} 1 & -1 \\ 1 & 2 \end{vmatrix} = (-1)^4(2 + 1) = 3$$

$$A_{21} = (-1)^{2+1} \begin{vmatrix} 3 & -1 \\ 2 & -1 \end{vmatrix} = (-1)^3(-3 + 2) = 1$$

$$A_{22} = (-1)^{2+2} \begin{vmatrix} 2 & -1 \\ 1 & -1 \end{vmatrix} = (-1)^4(-2 + 1) = -1$$

$$A_{23} = (-1)^{2+3} \begin{vmatrix} 2 & 3 \\ 1 & 2 \end{vmatrix} = (-1)^5(4 - 3) = -1$$

$$A_{31} = (-1)^{3+1} \begin{vmatrix} 3 & -1 \\ -1 & 1 \end{vmatrix} = (-1)^4(3 - 1) = 2$$

$$A_{32} = (-1)^{3+2} \begin{vmatrix} 2 & -1 \\ 1 & 1 \end{vmatrix} = (-1)^5(2 + 1) = -3$$

$$A_{33} = (-1)^{3+3} \begin{vmatrix} 2 & 3 \\ 1 & -1 \end{vmatrix} = (-1)^6(-2 - 3) = -5$$

$$\text{adj}A = \begin{bmatrix} A_{11} & A_{21} & A_{31} \\ A_{12} & A_{22} & A_{32} \\ A_{13} & A_{23} & A_{33} \end{bmatrix} = \begin{bmatrix} -1 & 1 & 2 \\ 2 & -1 & -3 \\ 3 & -1 & -5 \end{bmatrix}$$

$$A^{-1} = \frac{1}{|A|} \text{adj}A = \frac{1}{1} \begin{bmatrix} -1 & 1 & 2 \\ 2 & -1 & -3 \\ 3 & -1 & -5 \end{bmatrix} = \begin{bmatrix} -1 & 1 & 2 \\ 2 & -1 & -3 \\ 3 & -1 & -5 \end{bmatrix}$$

Since $X = A^{-1}B$

$$\Rightarrow \begin{bmatrix} x \\ y \\ z \end{bmatrix} = \begin{bmatrix} -1 & 1 & 2 \\ 2 & -1 & -3 \\ 3 & -1 & -5 \end{bmatrix} \begin{bmatrix} 1 \\ 3 \\ 1 \end{bmatrix} = \begin{bmatrix} -1 + 3 + 2 \\ 2 - 3 - 3 \\ 3 - 3 - 5 \end{bmatrix} = \begin{bmatrix} 4 \\ -4 \\ -5 \end{bmatrix}$$

$\therefore x = 4; y = -4$ and $z = -5$ is its solution.

Gauss Elimination Method (Echelon Form)

In this method, we reduce the associated augmented matrix for a given system of linear equations to its echelon form.

Example: Solve the system of equations by using Gauss elimination method

$$2x_1 - 3x_2 + 4x_3 = 1; x_1 + 2x_2 - x_3 = 2; 3x_1 + 5x_2 - 3x_3 = 5$$

Solution:

The associated augmented matrix is:

$$A_b = \begin{bmatrix} 2 & -3 & 4 & : & 1 \\ 1 & 2 & -1 & : & 2 \\ 3 & 5 & -3 & : & 5 \end{bmatrix}$$

First, we reduce it into echelon form.

$$\begin{aligned} & \sim_R \begin{bmatrix} 1 & 2 & -1 & : & 2 \\ 2 & -3 & 4 & : & 1 \\ 3 & 5 & -3 & : & 5 \end{bmatrix} && \text{by } R_{12} \\ & \sim_R \begin{bmatrix} 1 & 2 & -1 & : & 2 \\ 0 & -7 & 6 & : & -3 \\ 0 & -1 & 0 & : & -1 \end{bmatrix} && \begin{array}{l} \text{by } R_2 - 2R_1 \\ R_3 - 3R_1 \end{array} \\ & \sim_R \begin{bmatrix} 1 & 2 & -1 & : & 2 \\ 0 & -1 & 0 & : & -1 \\ 0 & -7 & 6 & : & -3 \end{bmatrix} && \text{by } R_{23} \\ & \sim_R \begin{bmatrix} 1 & 2 & -1 & : & 2 \\ 0 & 1 & 0 & : & 1 \\ 0 & -7 & 6 & : & -3 \end{bmatrix} && \text{by } -1R_2 \\ & \sim_R \begin{bmatrix} 1 & 2 & -1 & : & 2 \\ 0 & 1 & 0 & : & 1 \\ 0 & 0 & 6 & : & 4 \end{bmatrix} && \text{by } R_3 + 7R_2 \\ & \sim_R \begin{bmatrix} 1 & 2 & -1 & : & 2 \\ 0 & 1 & 0 & : & 1 \\ 0 & 0 & 1 & : & \frac{2}{3} \end{bmatrix} && \text{by } \frac{1}{6}R_3 \end{aligned}$$

Which is the echelon form of A_b . From the last row we have:

$$\begin{aligned} 0x_1 + 0x_2 + x_3 &= \frac{2}{3} \\ \Rightarrow x_3 &= \frac{2}{3} \end{aligned}$$

Key Facts

If $\text{Rank } A = \text{Rank } A_b = 3$
Then the system has a unique solution.

From second row we have:

$$\begin{aligned} 0x_1 + 1x_2 + 0x_3 &= 1 \\ \Rightarrow x_2 &= 1 \end{aligned}$$

From the first row, we have:

$$\begin{aligned} x_1 + 2x_2 - x_3 &= 2 \\ x_1 + 2(1) - \frac{2}{3} &= 2 \Rightarrow x_1 + \frac{4}{3} = 2 \\ \Rightarrow x_1 &= \frac{2}{3} \end{aligned}$$

$\therefore x_1 = \frac{2}{3}; \quad x_2 = 1; \quad x_3 = \frac{2}{3}$ is the solution of the system.

Gauss Jordan Method (Reduced Echelon Form)

In this method, we reduce the associated augmented matrix into reduced echelon form for the given system of non-homogeneous linear equations.

Example: Solve the system of given non-homogeneous linear equations

$$2x - 3y + 5z = 2; \quad x + 4y - 2z = 1; \quad 4x + 5y + z = 4,$$

by using Gauss-Jordan method.

Solution:

The associated augmented matrix is:

$$A_b = \begin{bmatrix} 2 & -3 & 5 & : & 2 \\ 1 & 4 & -2 & : & 1 \\ 4 & 5 & 1 & : & 4 \end{bmatrix}$$

First, we reduced it into the reduced echelon form.

$$\begin{aligned} &\sim R \begin{bmatrix} 1 & 4 & -2 & : & 1 \\ 2 & -3 & 5 & : & 2 \\ 4 & 5 & 1 & : & 4 \end{bmatrix} && \text{by } R_{12} \\ &\sim R \begin{bmatrix} 1 & 4 & -2 & : & 1 \\ 0 & -11 & 9 & : & 0 \\ 0 & -11 & 9 & : & 0 \end{bmatrix} && \begin{array}{l} \text{by } R_2 - 2R_1 \\ R_3 - 4R_1 \end{array} \\ &\sim R \begin{bmatrix} 1 & 4 & -2 & : & 1 \\ 0 & 1 & -\frac{9}{11} & : & 0 \\ 0 & -11 & 9 & : & 0 \end{bmatrix} && \text{by } \frac{-1}{11}R_{12} \\ &\sim R \begin{bmatrix} 1 & 0 & \frac{14}{11} & : & 1 \\ 0 & 1 & -\frac{9}{11} & : & 0 \\ 0 & 0 & 0 & : & 0 \end{bmatrix} && \begin{array}{l} \text{by } R_1 - 4R_2 \\ R_3 + 11R_2 \end{array} \end{aligned}$$

Observe that $\text{Rank } A = \text{Rank } A_b = 2$, which is less than the number of unknowns. Therefore system has infinite many solutions. From the last row, we have:

$$0x + 0y + 0z = 0$$

This equation is true for all values of the unknowns involved; so let $z = t$.

From second row, we have:

$$\begin{aligned} 0x + y - \frac{9}{11}z &= 0 \\ \Rightarrow y - \frac{9}{11}t &= 0 \Rightarrow y = \frac{9}{11}t \end{aligned}$$

From row one, we have:

$$\begin{aligned} x + 0y + \frac{14}{11}z &= 1 \\ \Rightarrow x + \frac{14}{11}t &= 1 \Rightarrow x = 1 - \frac{14}{11}t \end{aligned}$$

Thus, $x = 1 - \frac{14}{11}t$; $y = \frac{9}{11}t$; $z = t$ provide us infinite many solutions by assigning different values to the parameter 't'.

Cramer's Rule

Consider a system of non-homogeneous linear equations:

$$\begin{aligned} a_1x + b_1y + c_1z &= k_1 \\ a_2x + b_2y + c_2z &= k_2 \\ a_3x + b_3y + c_3z &= k_3 \end{aligned}$$

The system may be written in matrix form as $AX = B$.

If A is non-singular then $|A| \neq 0$ and A^{-1} exists.

$$\begin{aligned} \therefore A^{-1}(AX) &= A^{-1}B \\ \Rightarrow (A^{-1}A)X &= A^{-1}B \\ \Rightarrow IX &= A^{-1}B \\ \Rightarrow X &= A^{-1}B \end{aligned}$$

Since,

$$A^{-1} = \frac{1}{|A|} (\text{adj}A)$$

So

$$X = \frac{1}{|A|} (\text{adj}A)B$$

$$\Rightarrow X = \frac{1}{|A|} \begin{bmatrix} A_{11} & A_{21} & A_{31} \\ A_{12} & A_{22} & A_{32} \\ A_{13} & A_{23} & A_{33} \end{bmatrix} \begin{bmatrix} k_1 \\ k_2 \\ k_3 \end{bmatrix} = \frac{1}{|A|} \begin{bmatrix} k_1 A_{11} + k_2 A_{21} + k_3 A_{31} \\ k_1 A_{12} + k_2 A_{22} + k_3 A_{32} \\ k_1 A_{13} + k_2 A_{23} + k_3 A_{33} \end{bmatrix}$$

$$\Rightarrow \begin{bmatrix} x \\ y \\ z \end{bmatrix} = \begin{bmatrix} \frac{k_1 A_{11} + k_2 A_{21} + k_3 A_{31}}{|A|} \\ \frac{k_1 A_{12} + k_2 A_{22} + k_3 A_{32}}{|A|} \\ \frac{k_1 A_{13} + k_2 A_{23} + k_3 A_{33}}{|A|} \end{bmatrix}$$

Comparing the elements, we have

$$x = \frac{k_1 A_{11} + k_2 A_{21} + k_3 A_{31}}{|A|}$$

$$y = \frac{k_1 A_{12} + k_2 A_{22} + k_3 A_{32}}{|A|}$$

$$z = \frac{k_1 A_{13} + k_2 A_{23} + k_3 A_{33}}{|A|}$$

Now $k_1 A_{11} + k_2 A_{21} + k_3 A_{31}$

$$= k_1 \left((-1)^{1+1} \begin{vmatrix} b_2 & c_2 \\ b_3 & c_3 \end{vmatrix} \right) + k_2 \left((-1)^{2+1} \begin{vmatrix} b_1 & c_1 \\ b_3 & c_3 \end{vmatrix} \right) + k_3 \left((-1)^{3+1} \begin{vmatrix} b_1 & c_1 \\ b_2 & c_2 \end{vmatrix} \right)$$

$$= k_1 \begin{vmatrix} b_2 & c_2 \\ b_3 & c_3 \end{vmatrix} - k_2 \begin{vmatrix} b_1 & c_1 \\ b_3 & c_3 \end{vmatrix} + k_3 \begin{vmatrix} b_1 & c_1 \\ b_2 & c_2 \end{vmatrix} = \begin{vmatrix} k_1 & b_1 & c_1 \\ k_2 & b_2 & c_2 \\ k_3 & b_3 & c_3 \end{vmatrix}$$

Thus,

$$x = \frac{\begin{vmatrix} k_1 & b_1 & c_1 \\ k_2 & b_2 & c_2 \\ k_3 & b_3 & c_3 \end{vmatrix}}{|A|}$$

Similarly,

$$y = \frac{\begin{vmatrix} a_1 & k_1 & c_1 \\ a_2 & k_2 & c_2 \\ a_3 & k_3 & c_3 \end{vmatrix}}{|A|}$$

Remember



Like matrix inversion method; Cramer rule can be used only if A is non-singular.

$$z = \frac{\begin{vmatrix} a_1 & b_1 & k_1 \\ a_2 & b_2 & k_2 \\ a_3 & b_3 & k_3 \end{vmatrix}}{|A|}$$

Example: Solve the given system of non-homogeneous linear equations

$$2x - 3y + 5z = 1; \quad x + y + 2z = 3; \quad 3x - 2y - 4z = 0$$

by Cramer's rule.

Solution:

The above system may be written as $AX = B$; where,

$$A = \begin{bmatrix} 2 & -3 & 5 \\ 1 & 1 & 2 \\ 3 & -2 & -4 \end{bmatrix}; \quad X = \begin{bmatrix} x \\ y \\ z \end{bmatrix}; \quad B = \begin{bmatrix} 1 \\ 3 \\ 0 \end{bmatrix}$$

$$|A| = \begin{vmatrix} 2 & -3 & 5 \\ 1 & 1 & 2 \\ 3 & -2 & -4 \end{vmatrix} = 2 \begin{vmatrix} 1 & 2 \\ -2 & -4 \end{vmatrix} + 3 \begin{vmatrix} 1 & 2 \\ 3 & -4 \end{vmatrix} + 5 \begin{vmatrix} 1 & 1 \\ 3 & -2 \end{vmatrix}$$

$$= 2(-4 + 4) + 3(-4 - 6) + 5(-2 - 3) = 0 - 30 - 25$$

$$= -55 \neq 0$$

So, A is non-singular.

$$\begin{aligned} \therefore x &= \frac{\begin{vmatrix} 1 & -3 & 5 \\ 3 & 1 & 2 \\ 0 & -2 & -4 \end{vmatrix}}{|A|} = \frac{1 \begin{vmatrix} 1 & 2 \\ -2 & -4 \end{vmatrix} + 3 \begin{vmatrix} 3 & 2 \\ 0 & -4 \end{vmatrix} + 5 \begin{vmatrix} 3 & 1 \\ 0 & -2 \end{vmatrix}}{-55} \\ &= \frac{1(-4 + 4) + 3(-12 - 0) + 5(-6 - 0)}{-55} \end{aligned}$$

$$= \frac{-66}{-55} = \frac{6}{5}$$

$$\begin{aligned} y &= \frac{\begin{vmatrix} 2 & 1 & 5 \\ 1 & 3 & 2 \\ 3 & 0 & -4 \end{vmatrix}}{|A|} = \frac{2 \begin{vmatrix} 3 & 2 \\ 0 & -4 \end{vmatrix} - 1 \begin{vmatrix} 1 & 2 \\ 3 & -4 \end{vmatrix} + 5 \begin{vmatrix} 1 & 3 \\ 3 & 0 \end{vmatrix}}{-55} \\ &= \frac{2(-12 - 0) - 1(-4 - 6) + 5(0 - 9)}{-55} \end{aligned}$$

$$= \frac{-24 + 10 - 45}{-55} = \frac{59}{55}$$

$$z = \frac{\begin{vmatrix} 2 & -3 & 1 \\ 1 & 1 & 3 \\ 3 & -2 & 0 \end{vmatrix}}{|A|} = \frac{2 \begin{vmatrix} 1 & 3 \\ -2 & 0 \end{vmatrix} + 3 \begin{vmatrix} 1 & 3 \\ 3 & 0 \end{vmatrix} + 1 \begin{vmatrix} 1 & 1 \\ 3 & -2 \end{vmatrix}}{-55} = \frac{2(0 + 6) + 3(0 - 9) + 1(-2 - 3)}{-55}$$

$$= \frac{12 - 27 - 5}{-55} = \frac{4}{11}$$

Application of Matrices

Matrices are used in many disciplines. For example, in cryptography. We explain the process of encryption and decryption by means of an example.

Suppose that the sender and receiver consider messages in alphabets *A* to *Z* only, both assign the numbers 1 to 26 to the letters *A* to *Z* respectively, and the number 0 to a blank space. For simplicity, the sender employs a key as post-multiplication by a non-singular matrix of order 3 of his own choice. The receiver uses post-multiplication by the inverse of the matrix which has been chosen by the sender.

Let the encoding matrix be

$$A = \begin{bmatrix} 1 & -1 & 1 \\ 2 & -1 & 0 \\ 1 & 0 & 0 \end{bmatrix}$$

Let the message to be sent by the sender be "WELCOME".

Since the key is taken as the operation of post-multiplication by a square matrix of order 3, the message is cut into pieces (WEL), (COM), (E), each of length 3, and converted into a sequence of row matrices of numbers:

$$[23 \ 5 \ 12], [3 \ 15 \ 13], [5 \ 0 \ 0].$$

Note that, we have included two zeros in the last row matrix. The reason is to get a row matrix with 5 as the first entry.

Next, we encode the message by post-multiplying each row matrix as given below:

| Uncoded Row matrix | Encoding Matrix | Coded row Matrix |
|--------------------|---|------------------|
| [23 5 12] | $\begin{bmatrix} 1 & -1 & 1 \\ 2 & -1 & 0 \\ 1 & 0 & 0 \end{bmatrix}$ | [45 -28 23] |

| | | |
|-----------------|---|------------------|
| $[3 \ 15 \ 13]$ | $\begin{bmatrix} 1 & -1 & 1 \\ 2 & -1 & 0 \\ 1 & 0 & 0 \end{bmatrix}$ | $[46 \ -18 \ 3]$ |
| $[5 \ 0 \ 0]$ | $\begin{bmatrix} 1 & -1 & 1 \\ 2 & -1 & 0 \\ 1 & 0 & 0 \end{bmatrix}$ | $[5 \ -5 \ 5]$ |

So the encoded message is $[45 \ -28 \ -23][46 \ -18 \ 3][5 \ -5 \ 5]$

The receiver will decode the message by the reverse key, post-multiplying by the inverse of A. So the decoding matrix is

$$A^{-1} = \frac{1}{|A|} \text{adj}A = \begin{bmatrix} 0 & 0 & 1 \\ 0 & -1 & 2 \\ 1 & -1 & 1 \end{bmatrix}$$

The receiver decodes the coded message as follows:

| Coded Row matrix | Decoded Matrix | Decoded Row matrix |
|--------------------|---|--------------------|
| $[45 \ -28 \ -23]$ | $\begin{bmatrix} 0 & 0 & 1 \\ 0 & -1 & 2 \\ 1 & -1 & 1 \end{bmatrix}$ | $[23 \ 5 \ 12]$ |
| $[46 \ -18 \ 3]$ | $\begin{bmatrix} 0 & 0 & 1 \\ 0 & -1 & 2 \\ 1 & -1 & 1 \end{bmatrix}$ | $[3 \ 15 \ 13]$ |
| $[5 \ -5 \ 5]$ | $\begin{bmatrix} 0 & 0 & 1 \\ 0 & -1 & 2 \\ 1 & -1 & 1 \end{bmatrix}$ | $[5 \ 0 \ 0]$ |

So, the sequence of decoded row matrices is $[23 \ 5 \ 12]$, $[3 \ 15 \ 13]$, $[5 \ 0 \ 0]$.

Thus, the receiver reads the message as "WELCOME".

Exercise 2.6

1. Solve the following system of homogeneous linear equations for non-trivial solution if exists.

(i) $2x_1 - 3x_2 + 4x_3 = 0$

$$x_1 - 2x_2 + 3x_3 = 0$$

$$4x_1 + x_2 - 6x_3 = 0$$

(iii) $x_1 + x_2 - 3x_3 = 0$

$$3x_1 - 2x_2 + x_3 = 0$$

$$4x_1 - x_2 - 2x_3 = 0$$

(ii) $2x_1 - 3x_2 + 4x_3 = 0$

$$x_1 + x_2 + x_3 = 0$$

$$x_1 - 4x_2 + 3x_3 = 0$$

(iv) $5x_1 + 6x_2 - 7x_3 = 0$

$$2x_1 - x_2 + x_3 = 0$$

$$x_1 + 2x_2 + 2x_3 = 0$$

2. Find the value of λ for which the following system of homogeneous linear equations may have non-trivial solution. Also solve the system for value of λ .

(i) $2x_1 - \lambda x_2 + x_3 = 0$

$$2x_1 + 3x_2 - x_3 = 0$$

$$3x_1 - 2x_2 + 4x_3 = 0$$

(ii) $x_1 - 4x_2 + 3x_3 = 0$

$$2x_1 + \lambda x_2 + x_3 = 0$$

$$x_1 - 2x_2 + \lambda x_3 = 0$$

3. Solve the following system of linear equations by Gauss elimination method.

(i) $2x + 3y + 4z = 2$

$$2x + y + z = 5$$

$$3x - 2y + z = -3$$

(ii) $5x - 2y + z = 2$

$$2x + 2y + 6z = 1$$

$$3x - 4y - 5z = 3$$

(iii) $2x + z = 2$

$$2y - z = 3$$

$$x + 3y = 5$$

(iv) $x + 2y + 5z = 4$

$$3x - 2y + 2z = 3$$

$$5x - 8y - 4z = 1$$

4. Solve the following system of linear equations by Gauss-Jordan method.

(i) $2x_1 - x_2 - x_3 = 2$

$$3x_1 - 4x_2 + 3x_3 = 7$$

$$4x_1 + 2x_2 - 5x_3 = 10$$

(ii) $2x_1 - 3x_2 + 7x_3 = 1$

$$4x_1 + 5x_2 - 3x_3 = 4$$

$$10x_1 - 4x_2 + 18x_3 = 7$$

(iii) $x_1 + x_2 + x_3 = 3$

$$2x_1 - 3x_2 + 2x_3 = 7$$

$$4x_1 + 2x_2 - 5x_3 = 10$$

(iv) $2x_1 - 7x_2 + 10x_3 = 1$

$$x_1 + 2x_2 - 4x_3 = 8$$

$$2x_1 - 11x_2 + 13x_3 = 7$$

5. Solve the following system of linear equations by using Cramer's rule.

(i) $x_1 + x_2 + 2x_3 = 8$

$$-x_1 - 2x_2 + 3x_3 = 1$$

$$3x_1 - 7x_2 + 4x_3 = 10$$

(ii) $2x_1 + 2x_2 + x_3 = 0$

$$-2x_1 + 5x_2 + 2x_3 = 1$$

$$8x_1 + x_2 + 4x_3 = -1$$

(iii) $-2x_2 + 3x_3 = 1$

$$3x_1 + 6x_2 - 3x_3 = -2$$

$$6x_1 + 6x_2 + 3x_3 = 5$$

(iv) $2x_1 + x_2 + 3x_3 = 1$

$$x_1 - 2x_2 + x_3 = 2$$

$$3x_1 - 4x_2 - x_3 = 4$$

6. Solve the following system of linear equations by matrix inversion method.

(i) $5x + 3y + z = 6$
 $2x + y + 3z = 19$
 $x + 2y + 4z = 25$

(ii) $x + 2y - 3z = 5$
 $2x - 3y + 2z = 1$
 $-x + 2y - 5z = -3$

(iii) $-x + 3y - 5z = 0$
 $2x + 4y - 6z = 1$
 $x - 2y + 3z = 3$

(iv) $\frac{2}{x} + \frac{3}{y} + \frac{10}{z} = 4$
 $\frac{4}{x} - \frac{6}{y} + \frac{5}{z} = 1$
 $\frac{6}{x} + \frac{9}{y} - \frac{20}{z} = 2$

7. If $A = \begin{bmatrix} 3 & 2 & 1 \\ 4 & -1 & 2 \\ 7 & 3 & -3 \end{bmatrix}$; find A^{-1} and hence solve the system of equations.

$3x + 4y + 7z = 14$; $2x - y + 3z = 4$; $x + 2y - 3z = 0$.

8. Determine the value of λ for which the following system has no solution, unique solution or infinitely many solutions.

$x + 2y - 3z = 4$; $3x - y + 5z = 2$; $4x + y + (\lambda^2 - 14)z = \lambda + 2$

9. Show that the system of equations

$2x - y + 3z = \alpha$; $3x + y - 5z = \beta$; $-5x - 5y + 21z = \gamma$

is inconsistent if $\gamma \neq 2\alpha - 3\beta$.

10. By making use of matrix of order 2 by 2 and 3 by 3 encode and decode the following words:

a. PAKISTAN

b. ISLAMABAD

c. COLLEGE

I have Learnt

- Applying matrix operations (addition/subtraction and multiplication of (matrices) with real and complex entries.
- Evaluating determinants of 3×3 matrix by using cofactors and properties of determinants.
- Using row operations to find the inverse and the rank of a matrix.
- Explaining a consistent and inconsistent system of linear equations and demonstrate through examples.
- Solving a system of 3 by 3 nonhomogeneous linear equations by using matrix inversion method and Cramer's Rule.
- Solving a system of three homogeneous linear equations in three unknowns using the Gaussian elimination method.
- Applying concepts of matrices to real world problems such as (graphic design, data encryption, seismic analysis, cryptography, transformation of geometric shapes, social network analysis).

Review Exercise

1. Select the best matching option.

- (i) If order of A is $m \times n$ and order of B is $n \times p$ then order of AB is:
 (a) $n \times p$ (b) $m \times p$ (c) $p \times m$ (d) $n \times n$
- (ii) If A is a row matrix of order $1 \times n$ then order of $A^t A$ is:
 (a) $1 \times n$ (b) $n \times 1$ (c) 1×1 (d) $n \times n$
- (iii) For an element a_{ij} of a square matrix A :
 (a) $a_{ij} = (-1)^{i+j} A_{ij}$ (b) $a_{ij} = (-1)^{i+j} M_{ij}$ (c) $\frac{A_{ij}}{M_{ij}} = (-1)^{i+j}$ (d) $a_{ij} = M_{ij}$
- (iv) If A is any matrix then A and A^t are always conformable for:
 (a) Addition (b) multiplication (c) subtraction (d) all of these
- (v) If A is a square matrix of order 3×3 and $|A| = 3$ then value of $|adjA|$ is:
 (a) 3 (b) $1/3$ (c) 9 (d) 6
- (vi) For the square matrix A of order 3×3 with $|A| = 9$; $A_{21} = 2$; $A_{22} = 3$; $A_{23} = -1$; $a_{21} = 1$; $a_{23} = 2$, the value of a_{22} is:
 (a) 2 (b) 3 (c) 9 (d) -1
- (vii) System of homogeneous linear equations has non-trivial solution if:
 (a) $|A| > 0$ (b) $|A| < 0$ (c) $|A| = 0$ (d) $|A| \neq 0$
- (viii) For non-homogeneous system of equations; the system is inconsistent if:
 (a) $RankA = Rank A_b$ (b) $RankA \neq Rank A_b$
 (c) $RankA < no. of variables$ (d) $RankA_b > no. of variables$
- (ix) For a system of non-homogeneous equations with three variables system will have unique solution if:
 (a) $RankA < 3$ (b) $RankA_b < 3$
 (c) $RankA = RankA_b = 3$ (d) $RankA = RankA_b < 3$
- (x) A system of non-homogeneous equation having infinite many solutions can be solved by using:
 (a) Inversion method (b) Cramer's rule
 (c) Gauss-Jordan method (d) all of these

2. For the matrix $A = \begin{bmatrix} 1 & 2 & 0 \\ -3 & 4 & 9 \\ 2 & 1 & 6 \end{bmatrix}$; find A_{13} , A_{23} and A_{33} ; hence find $|A|$.

3. Prove that if $A^{-1} = A^t$ then $|AA^t| = 1$.

4. Without expanding show that $\begin{vmatrix} a+1 & l & l \\ l & a+1 & l \\ l & l & a+1 \end{vmatrix} = (a+1+2l)(a+1-l)^2$.

5. Find the value of λ so that the following system has infinite many solutions.

$$2x - 3y + z = 1; x - 2y + \lambda z = 2; 3y + z = -1$$

UNIT
03

VECTORS

After studying this unit, students will be able to:

- Recognize rectangular coordinate system in space.
- Recognize: unit vectors and \hat{i} , \hat{j} and \hat{k} components of a vector.
- Find the magnitude of a vector.
- Demonstrate and prove properties of Vector Addition.
- Explain dot or scalar product of two vectors and give its geometrical interpretation. Express dot product in terms of components.
- Find the condition for orthogonality of two vectors and angle between them.
- Find the projection of a vector along another vector and work done by a force.
- Explain the cross or vector product of two vectors and give its geometrical interpretation. Apply cross product to find an angle between two vectors.
- Describe scalar triple product of vectors and express it in terms of components.
- Understand that dot and cross product are interchangeable in scalar triple product
- Recognize coplanar vectors and find the condition for planarity of three vectors.

Vectors are utilised in day-to-day life to assist in the localization of people, places, and things. They are also used to describe things that are acting in response to an external force being applied to them. A quantity that possesses both a magnitude and a direction is known as a vector. The first, second, and third laws of Newton are all relationships between vectors that precisely describe the motion of bodies when they are subjected to the influence of an outside force. Newton's laws cover a wide range of phenomena and can be used to describe anything from a ball in free fall to a rocket on its way to the moon.

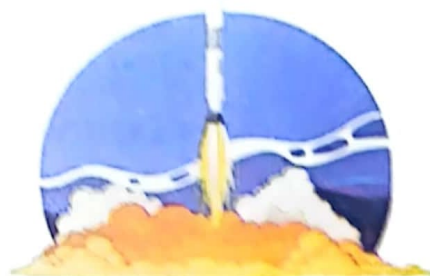

3.1 Vectors Introduction

Scalar

A physical quantity which can be completely specified by its magnitude only is called a scalar. e.g., mass, time, distance, volume, etc.

Vector

A physical quantity which is completely specified by its magnitude and direction as well. e.g., weight, displacement, velocity, acceleration, etc.

3.1.1 Geometrical Representation of a Vector

Geometrically a vector is represented by a line segment with an arrow head at its one end. The length of the line segment describes the magnitude and the arrow head indicates the direction of the vector.

The end A is called the tail or the initial point of the vector and the end B is called the terminal point. In the figure vector AB is shown. It is denoted by \vec{AB} .

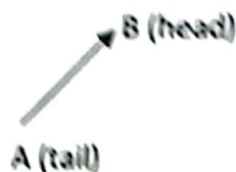

Usually, the vectors are denoted by bold face letters $\mathbf{a}, \mathbf{b}, \mathbf{c}$ etc.; or $\vec{a}, \vec{b}, \vec{c}$. There are also other notations to denote a vector like $\underline{a}, \underline{b}, \underline{c}$ etc.

3.1.2 Some Fundamental Definitions of Terms Related to Vectors

Magnitude of a Vector

In the figure vector \vec{OA} is denoted by \vec{a} . The magnitude or the length or the norm of the vector \vec{OA} denoted by $|\vec{OA}|$ or $|\vec{a}|$.



Equal Vectors

Two vectors \vec{a} and \vec{b} are said to be equal if both have the same magnitude and direction.

It is not necessary for the equal vectors to have the same position. If vectors \vec{a} and \vec{b} are equal then we write $\vec{a} = \vec{b}$.

Geometrically two vectors are equal if they are translation of one another.

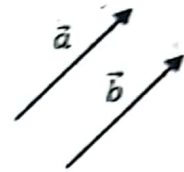

Negative of a Vector

A vector having the same magnitude but opposite in direction of a vector \vec{a} is called the negative of \vec{a} and is denoted by $-\vec{a}$.

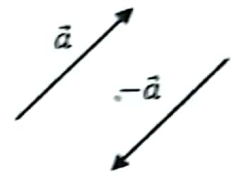

Zero or Null Vector

If the initial and terminal points of a vector coincide then the vector has zero length. This vector is called zero vector and is denoted by $\vec{0}$. The zero vector has no direction. It can be assigned as convenient direction according to the situation.

Unit Vector

A vector which is in the direction of non-zero vector \vec{a} and has magnitude 1 is called unit vector of \vec{a} and is denoted by \hat{a} . If \vec{a} is non-zero vector of arbitrary length $|\vec{a}|$ then $\hat{a} = \frac{\vec{a}}{|\vec{a}|}$.

$$\Rightarrow \vec{a} = |\vec{a}|\hat{a}.$$

This means any vector \vec{a} can be obtained by multiplying the magnitude of the vector to its unit vector. The process of finding the unit vector of a vector \vec{a} , is called normalizing vector \vec{a} .

Parallel Vectors

Two non-zero vectors \vec{a} and \vec{b} are said to be parallel if $\vec{a} = \lambda\vec{b}$; where λ is a scalar. If value of λ is positive then both vectors have the same direction and if value of λ is negative then both are in the opposite direction. The vectors which are in the opposite direction are known as antiparallel vectors.

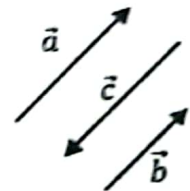

Position Vector

The vector used to specify the position of a point P with respect to origin O is called position vector of P. The tail of this vector is at origin and tip at the point P. Thus \vec{OP} is the position vector of point P with respect to O.

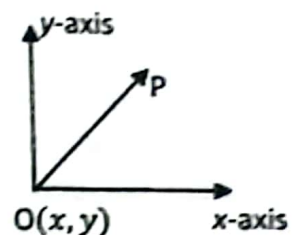

Addition of Vectors

Head to Tail Rule or Triangle Law of Addition

To add non-zero vectors \vec{a} and \vec{b} , join the tail of the second vector with the head of the first vector. Now the vector obtained by joining the tail of the first vector to head of the second vector is the vector $\vec{a} + \vec{b}$.

$\vec{a} + \vec{b}$ is known as resultant vector of \vec{a} and \vec{b} .

This method for the addition of two vectors is called head to tail rule of addition. Since \vec{a} , \vec{b} and $\vec{a} + \vec{b}$ are along the sides of a triangle ABC, so the rule of addition is also called triangle law of addition.

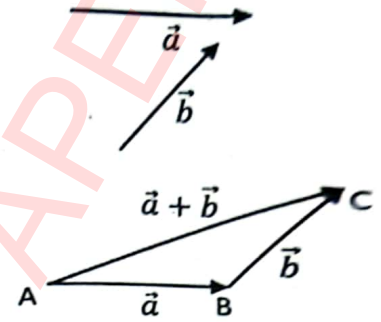

Parallelogram Law of Addition

Consider any parallelogram ABCD. Let $\vec{AB} = \vec{a}$ and $\vec{AD} = \vec{b}$.

Since the vector \vec{BC} has the same magnitude and direction as that of \vec{AD} ; so $\vec{BC} = \vec{AD}$. Also \vec{DC} has the same magnitude and direction as that of \vec{AB} so $\vec{DC} = \vec{AB}$.

Using triangle law of addition, we have

$$\vec{AB} + \vec{BC} = \vec{AC}$$

$$\text{i.e.; } \vec{a} + \vec{b} = \vec{AC}$$

This mean diagonal vector \vec{AC} of the parallelogram is the sum of the vectors of \vec{a} and \vec{b} .

This is known as parallelogram law of addition.

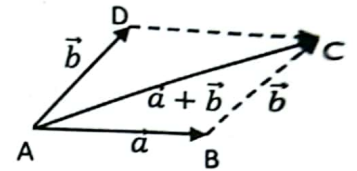

Polygon Law of Addition of Vectors

The process for the addition of vectors can be extended to any number of vectors. For instance, let we have five vectors $\vec{a}, \vec{b}, \vec{c}, \vec{d}, \vec{e}$ and we want to find $\vec{a} + \vec{b} + \vec{c} + \vec{d} + \vec{e}$.

For this draw $\vec{IA} = \vec{a}; \vec{AB} = \vec{b}; \vec{BC} = \vec{c}; \vec{CD} = \vec{d}; \vec{DE} = \vec{e}$

$$\begin{aligned} \text{Now } \vec{a} + \vec{b} + \vec{c} + \vec{d} + \vec{e} &= \vec{IA} + \vec{AB} + \vec{BC} + \vec{CD} + \vec{DE} \\ &= (\vec{IA} + \vec{AB}) + \vec{BC} + \vec{CD} + \vec{DE} \\ &= \vec{IB} + \vec{BC} + \vec{CD} + \vec{DE} \quad (\because \vec{IA} + \vec{AB} = \vec{IB}) \\ &= (\vec{IB} + \vec{BC}) + \vec{CD} + \vec{DE} \\ &= \vec{IC} + \vec{CD} + \vec{DE} \quad (\because \vec{IB} + \vec{BC} = \vec{IC}) \\ &= (\vec{IC} + \vec{CD}) + \vec{DE} \\ &= \vec{ID} + \vec{DE} \quad (\because \vec{IC} + \vec{CD} = \vec{ID}) \\ &= \vec{IE} \quad (\because \vec{ID} + \vec{DE} = \vec{IE}) \end{aligned}$$

Then \vec{IE} is the sum of all these five vectors.

Same method is adopted to find the sum of any number of vectors.

This is called polygon law of addition of vectors.

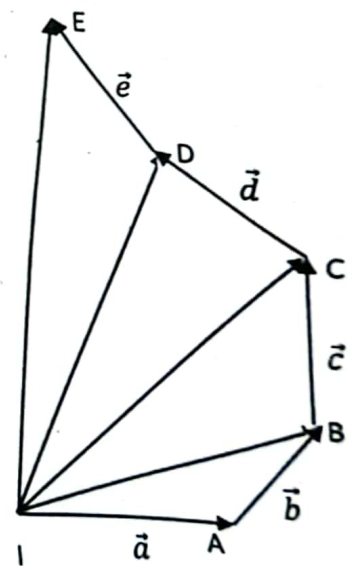

Subtraction of Two Vectors

Consider two non-zero vectors \vec{a} and \vec{b} then $\vec{a} - \vec{b} = \vec{a} + (-\vec{b})$.

To find $\vec{a} - \vec{b}$ draw $\overline{AB} = \vec{a}$ and $\overline{BC} = -\vec{b}$; then

$$\overline{AB} + \overline{BC} = \overline{AC}$$

$$\vec{a} + (-\vec{b}) = \overline{AC}$$

Thus \overline{AC} is the vector which represents $\vec{a} - \vec{b}$.

Scalar Multiplication

If λ is a non-zero scalar and \vec{a} is a non-zero vector then the scalar multiple $\lambda\vec{a}$ is a vector whose magnitude is $|\lambda|$ times magnitude of \vec{a} . $\lambda\vec{a}$ has the same direction as that of \vec{a} if λ is positive and if λ is negative then direction of $\lambda\vec{a}$ is in the opposite direction of \vec{a} .

If $\lambda\vec{a} = 0$ then either $\lambda = 0$ or $\vec{a} = 0$.

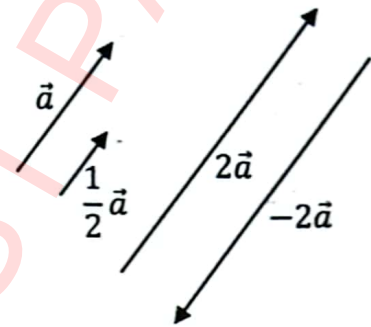
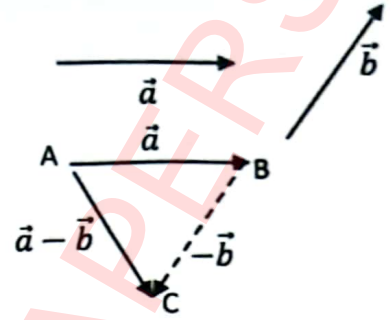

3.1.3 Position Vector of a Point Dividing the Line Segment in a Given Ratio

Case I

Let \overline{AB} be any line segment and P is the point which divides this line segment in the given ratio $m : n$ internally. The position vectors of the given points A and B are \vec{a} and \vec{b} respectively. Let \vec{r} be the position vector of point P .

Given that

$$|\overline{AP}| : |\overline{PB}| = m : n$$

$$\Rightarrow \frac{|\overline{AP}|}{|\overline{PB}|} = \frac{m}{n}$$

$$\Rightarrow n|\overline{AP}| = m|\overline{PB}|$$

Because \overline{AP} and \overline{PB} have the same direction; so

$$n\overline{AP} = m\overline{PB} \tag{1}$$

From figure

$$\overline{OA} + \overline{AP} = \overline{OP}$$

$$\Rightarrow \vec{a} + \overline{AP} = \vec{r}$$

$$\Rightarrow \overline{AP} = \vec{r} - \vec{a}$$

And

$$\overline{OP} + \overline{PB} = \overline{OB}$$

$$\Rightarrow \vec{r} + \overline{PB} = \vec{b}$$

$$\Rightarrow \overline{PB} = \vec{b} - \vec{r}$$

Substituting values in equation (1)

$$n(\vec{r} - \vec{a}) = m(\vec{b} - \vec{r})$$

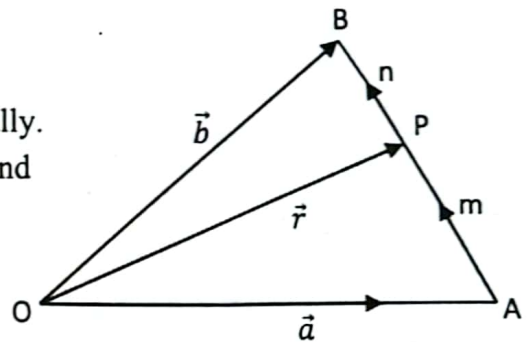

$$\begin{aligned} \Rightarrow n\vec{r} - n\vec{a} &= m\vec{b} - m\vec{r} \\ \Rightarrow n\vec{r} + m\vec{r} &= m\vec{b} + n\vec{a} \\ \Rightarrow (n + m)\vec{r} &= m\vec{b} + n\vec{a} \\ \Rightarrow \vec{r} &= \frac{m\vec{b} + n\vec{a}}{m + n} \end{aligned}$$

Case I

If $m : n = 1 : 1$ then $\frac{m}{n} = \frac{1}{1}$ or $m = n$. In this case P will be the midpoint of \overline{AB} and position vector of P in this case is:

$$\begin{aligned} \Rightarrow \vec{r} &= \frac{n\vec{b} + n\vec{a}}{n + n} && \because (m = n) \\ \Rightarrow \vec{r} &= \frac{n(\vec{b} + \vec{a})}{2n} = \frac{\vec{a} + \vec{b}}{2} \end{aligned}$$

Case II

When the point P divides the line segment \overline{AB} in the ratio $m : n$ externally then

$$\begin{aligned} |\overline{AP}| : |\overline{BP}| &= m : n \\ \Rightarrow \frac{|\overline{AP}|}{|\overline{BP}|} &= \frac{m}{n} \\ \Rightarrow n|\overline{AP}| &= m|\overline{BP}| \end{aligned}$$

Since \overline{AP} and \overline{BP} have the same direction thus,

$$\begin{aligned} n\overline{AP} &= m\overline{BP} \\ n(\vec{r} - \vec{a}) &= m(\vec{r} - \vec{b}) \\ \Rightarrow n\vec{r} - n\vec{a} &= m\vec{r} - m\vec{b} \\ \Rightarrow n\vec{r} - m\vec{r} &= n\vec{a} - m\vec{b} \\ \Rightarrow (n - m)\vec{r} &= n\vec{a} - m\vec{b} \\ \Rightarrow \vec{r} &= \frac{n\vec{a} - m\vec{b}}{n - m} \end{aligned}$$

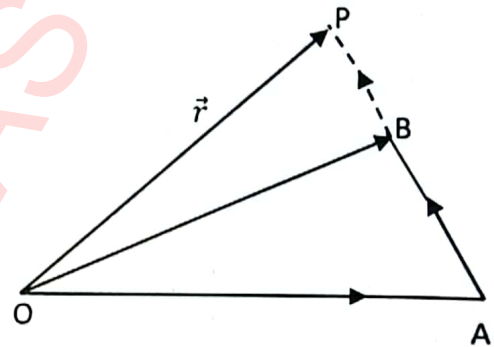

3.1.4 Application to Geometry

Here we are giving some simple geometrical proofs by using vector methods.

Theorem: The diagonals of a parallelogram bisect each other.

Proof:

Consider any parallelogram ABCD. Let $\vec{a}, \vec{b}, \vec{c}$ and \vec{d} be the position vectors of the vertices A, B, C and D respectively.

Now the position vector of the midpoint M_1 of the diagonal \overline{AC} is $\frac{\vec{a} + \vec{c}}{2}$.

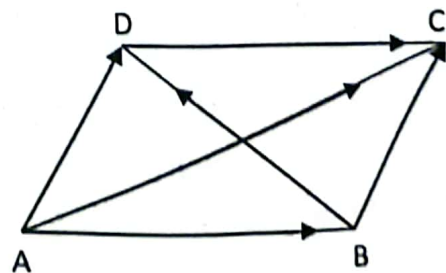

i.e.; p.v of $M_1 = \frac{\vec{a} + \vec{c}}{2}$ (1)

And the position vector of the midpoint M_2 of the diagonal \overline{BD} is $\frac{\vec{b} + \vec{d}}{2}$. i.e.;

p.v of $M_2 = \frac{\vec{b} + \vec{d}}{2}$ (2)

Since ABCD is a parallelogram then:

$$\begin{aligned} \overline{AB} &= \overline{DC} \\ \Rightarrow \vec{b} - \vec{a} &= \vec{c} - \vec{d} \\ \Rightarrow \vec{b} + \vec{d} &= \vec{a} + \vec{c} \end{aligned}$$

Dividing with 2:

$$\text{p.v of } M_2 = \frac{\vec{b} + \vec{d}}{2} = \frac{\vec{a} + \vec{c}}{2} = \text{p.v of } M_1$$

Since the position vectors of the point of intersection of both the diagonals are same. Thus, they bisect each other.

Theorem: Line joining the midpoints of any two sides of a triangle is parallel to the third side and half in length of third side.

Proof:

Consider any triangle ABC. Let \vec{a}, \vec{b} and \vec{c} be the position vectors of the vertices A, B and C respectively.

Let M_1 and M_2 be the midpoints of the sides \overline{CA} and \overline{BC} respectively therefore:

$$\text{Position vector of } M_1 = \frac{\vec{a} + \vec{c}}{2}$$

$$\text{Position vector of } M_2 = \frac{\vec{b} + \vec{c}}{2}$$

Now
$$\begin{aligned} \overline{M_1M_2} &= \frac{\vec{b} + \vec{c}}{2} - \frac{\vec{a} + \vec{c}}{2} \\ &= \frac{1}{2}(\vec{b} + \vec{c} - \vec{a} - \vec{c}) = \frac{1}{2}(\vec{b} - \vec{a}) = \frac{1}{2}\overline{AB} \end{aligned}$$

This shows that $\overline{M_1M_2}$ is parallel to \overline{AB} . Also

$$|\overline{M_1M_2}| = \left| \frac{1}{2}\overline{AB} \right| = \frac{1}{2}|\overline{AB}|$$

This shows that length of $\overline{M_1M_2}$ is half the length of \overline{AB} .

Theorem: The joining of the midpoints of the two non-parallel sides of a trapezium is parallel to its parallel sides and its length is half the sum of the lengths of the parallel sides.

Proof

Consider any trapezium ABCD with two parallel sides \overline{AB} and \overline{DC} .

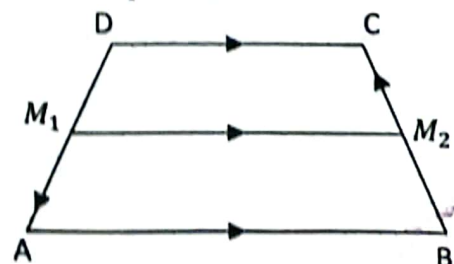
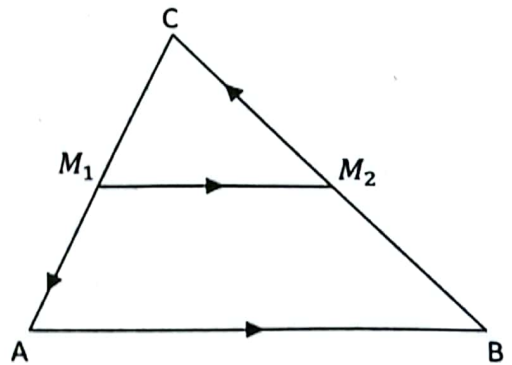

Let $\vec{a}, \vec{b}, \vec{c}$ and \vec{d} be the position vectors of the vertices A, B, C and D respectively. Also suppose that M_1 and M_2 be the midpoints of the non-parallel sides \overline{BC} and \overline{DA} respectively.

Therefore,

$$\text{Position vector of } M_1 = \frac{\vec{b} + \vec{c}}{2}$$

$$\text{Position vector of } M_2 = \frac{\vec{d} + \vec{a}}{2}$$

Now

$$\begin{aligned} \overrightarrow{M_1M_2} &= \frac{\vec{b} + \vec{c}}{2} - \frac{\vec{d} + \vec{a}}{2} \\ &= \frac{1}{2}(\vec{b} + \vec{c} - \vec{d} - \vec{a}) = \frac{1}{2}[(\vec{b} - \vec{a}) + (\vec{c} - \vec{d})] \\ &= \frac{1}{2}(\overrightarrow{AB} + \overrightarrow{DC}) \end{aligned} \tag{1}$$

Since \overrightarrow{AB} is parallel to \overrightarrow{DC} (given).

Thus $\overrightarrow{AB} = \lambda \overrightarrow{DC}$; where λ is some scalar.

Therefore $\overrightarrow{M_1M_2} = \frac{1}{2}(\lambda \overrightarrow{DC} + \overrightarrow{DC}) = \frac{1}{2}(\lambda + 1)\overrightarrow{DC}$

$$\overrightarrow{M_1M_2} = \mu \overrightarrow{DC} \quad \text{where } \mu = \frac{1}{2}(\lambda + 1) \text{ is a scalar.}$$

This shows that $\overrightarrow{M_1M_2}$ is parallel to \overrightarrow{DC} and \overrightarrow{AB} .

Thus $\overrightarrow{M_1M_2}$ is parallel to the parallel sides. Also, from (1) it is clear that length of $\overrightarrow{M_1M_2}$ is half the sum of the lengths of the parallel sides \overline{AB} and \overline{DC} .

3.2 Vectors in Space (Three-Dimensional Space)

3.2.1 Rectangular Coordinate System

To represent a vector in space we need a 3-dimensional coordinate system. For this we consider three mutually perpendicular lines intersecting at a common point O known as origin.

Any point in the space has some specific position w. r. t. origin O i.e.; We can locate the point by moving specific distance along these three lines.

These three lines are known as coordinate axes and are named as x-axis, y-axis and z-axis. The distance along x-axis is called x-coordinate, the distance along y-axis is y-coordinate and the distance along z-axis is z-coordinate of the point.

A general point in the space has coordinate (x, y, z) .

This coordinate system to represent or locate a point is known as rectangular coordinate system or Cartesian coordinate system and is denoted by $\mathcal{R} \times \mathcal{R} \times \mathcal{R}$ or \mathcal{R}^3 . The set of all the points in space is:

$$\mathcal{R}^3 = \{(x, y, z) : x, y, z \in \mathcal{R}\}.$$

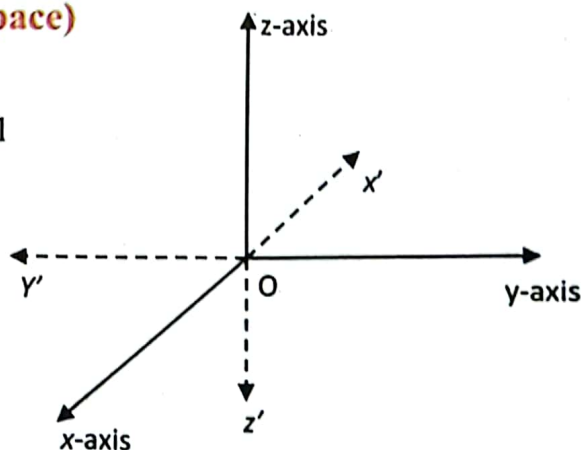

3.2.2 Unit Vectors \hat{i} , \hat{j} and \hat{k}

To represent a vector in space we need unit vectors in the direction of coordinate axes. For this we have three fundamental unit vectors \hat{i} , \hat{j} and \hat{k} along x-axis, y-axis and z-axis respectively.

3.2.3 Components of a Vector

Let \vec{OP} be the position vector of the point $P(x, y, z)$, then

$$\vec{OA} = x\hat{i}; \quad \vec{OB} = y\hat{j} \text{ and}$$

$$\vec{OC} = z\hat{k}$$

From figure it is clear that

$$\vec{OP} = \vec{OQ} + \vec{QP} \quad (1)$$

$$\text{Since } \vec{OA} + \vec{AQ} = \vec{OQ}$$

$$\Rightarrow \vec{OA} + \vec{OB} = \vec{OQ}$$

$$\therefore \vec{AQ} = \vec{OB}$$

$$\Rightarrow x\hat{i} + y\hat{j} = \vec{OQ}$$

$$\text{Or } \vec{OQ} = x\hat{i} + y\hat{j}$$

$$\text{Also } \vec{QP} = z\hat{k}$$

Putting values in equation (1), we have:

$$\vec{OP} = x\hat{i} + y\hat{j} + z\hat{k}$$

Which is the position vector of the point $P(x, y, z)$.

In the representation of the position vector $\vec{OP} = x\hat{i} + y\hat{j} + z\hat{k}$, x , y and z are known as components of the vector along x-axis, y-axis and z-axis respectively.

3.2.4 Analytical Representation of the Vector

The representation of a space vector in its component form $\vec{r} = x\hat{i} + y\hat{j} + z\hat{k}$ is known as analytic representation of the vector \vec{r} .

3.2.5 Magnitude of a Vector

Consider a space vector $\vec{r} = \vec{OP}$.

From figure

$$|\vec{OP}|^2 = |\vec{OQ}|^2 + |\vec{QP}|^2$$

$$\therefore \vec{OQ} = x\hat{i} + y\hat{j}$$

$$\Rightarrow |\vec{OQ}| = \sqrt{x^2 + y^2}$$

$$\text{and } |\vec{QP}| = z$$

Putting values in equation (1).

$$|\vec{r}|^2 = (\sqrt{x^2 + y^2})^2 + z^2$$

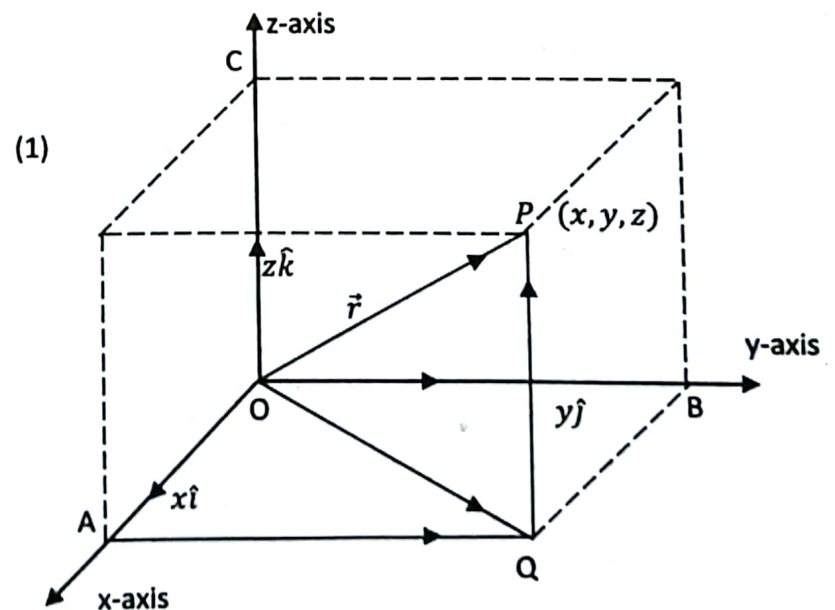
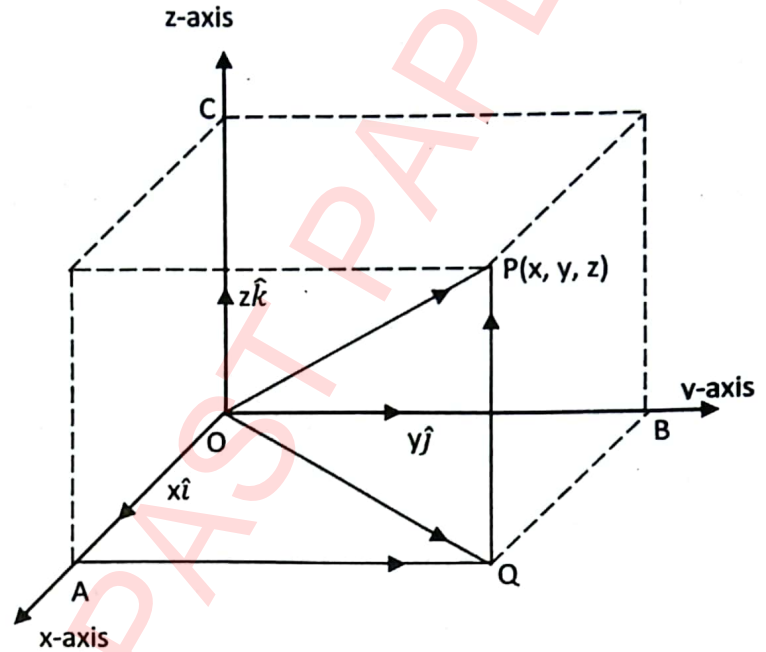

$$\Rightarrow |\vec{r}|^2 = x^2 + y^2 + z^2$$

$$\Rightarrow |\vec{r}| = \sqrt{x^2 + y^2 + z^2}$$

Which is the magnitude of a vector space

3.2.6 Fundamental Definitions for Vectors in Space

Unit Vector

Let $\vec{r} = x\hat{i} + y\hat{j} + z\hat{k}$ be a space vector. A unit vector \hat{r} in the direction of \vec{r} is given by

$$\begin{aligned} \hat{r} &= \frac{\vec{r}}{|\vec{r}|} \\ \Rightarrow \hat{r} &= \frac{x\hat{i} + y\hat{j} + z\hat{k}}{\sqrt{x^2 + y^2 + z^2}} \\ \Rightarrow \hat{r} &= \frac{x}{\sqrt{x^2 + y^2 + z^2}}\hat{i} + \frac{y}{\sqrt{x^2 + y^2 + z^2}}\hat{j} + \frac{z}{\sqrt{x^2 + y^2 + z^2}}\hat{k} \end{aligned}$$

Equal Vectors

Two space vectors $\vec{r}_1 = x_1\hat{i} + y_1\hat{j} + z_1\hat{k}$ and $\vec{r}_2 = x_2\hat{i} + y_2\hat{j} + z_2\hat{k}$ are said to be equal if they have the same corresponding components, i.e.;

$$\begin{aligned} \vec{r}_1 &= \vec{r}_2 \\ \Rightarrow x_1\hat{i} + y_1\hat{j} + z_1\hat{k} &= x_2\hat{i} + y_2\hat{j} + z_2\hat{k} \\ \Rightarrow x_1 = x_2; \quad y_1 = y_2; \quad z_1 = z_2 \end{aligned}$$

Zero Vector

A vector in space which has all its three components equal to zero is called zero vector. It is usually denoted by $\vec{0}$, i.e.;

$$\vec{0} = 0\hat{i} + 0\hat{j} + 0\hat{k}$$

Negative of a Vector

For a space vector $\vec{r} = x\hat{i} + y\hat{j} + z\hat{k}$ negative of \vec{r} is denoted by $-\vec{r}$ and is defined as:

$$-\vec{r} = (-x)\hat{i} + (-y)\hat{j} + (-z)\hat{k}$$

Scalar Multiplication

The product of a scalar λ with a space vector $\vec{r} = x\hat{i} + y\hat{j} + z\hat{k}$ is denoted by $\lambda\vec{r}$ and is defined as

$$\lambda\vec{r} = (\lambda x)\hat{i} + (\lambda y)\hat{j} + (\lambda z)\hat{k}$$

Parallel Vectors

Two non-zero vectors in space $\vec{r}_1 = x_1\hat{i} + y_1\hat{j} + z_1\hat{k}$ and $\vec{r}_2 = x_2\hat{i} + y_2\hat{j} + z_2\hat{k}$ are said to be parallel if there exists some non-zero scalar λ such that $\vec{r}_1 = \lambda\vec{r}_2$, i.e.;

$$\begin{aligned} x_1\hat{i} + y_1\hat{j} + z_1\hat{k} &= \lambda(x_2\hat{i} + y_2\hat{j} + z_2\hat{k}) \\ \Rightarrow x_1\hat{i} + y_1\hat{j} + z_1\hat{k} &= (\lambda x_2)\hat{i} + (\lambda y_2)\hat{j} + (\lambda z_2)\hat{k} \end{aligned}$$

$$\begin{aligned} \Rightarrow x_1 &= \lambda x_2; & y_1 &= \lambda y_2; & z_1 &= \lambda z_2 \\ \Rightarrow \frac{x_1}{x_2} &= \lambda; & \frac{y_1}{y_2} &= \lambda; & \frac{z_1}{z_2} &= \lambda \\ \Rightarrow \frac{x_1}{x_2} &= \frac{y_1}{y_2} = \frac{z_1}{z_2} = \lambda \end{aligned}$$

Which is the condition for two vectors to be parallel. For positive value of λ vectors will have the same direction and will be in opposite direction if λ is negative.

Addition of Two Vectors

Consider two vectors $\vec{r}_1 = x_1\hat{i} + y_1\hat{j} + z_1\hat{k}$ and $\vec{r}_2 = x_2\hat{i} + y_2\hat{j} + z_2\hat{k}$ in space. Their sum $\vec{r}_1 + \vec{r}_2$ is defined as:

$$\begin{aligned} \vec{r}_1 + \vec{r}_2 &= (x_1\hat{i} + y_1\hat{j} + z_1\hat{k}) + (x_2\hat{i} + y_2\hat{j} + z_2\hat{k}) \\ &= (x_1 + x_2)\hat{i} + (y_1 + y_2)\hat{j} + (z_1 + z_2)\hat{k}. \end{aligned}$$

3.3 Properties of Vector Addition

3.3.1 Commutative Law for Vector Addition

Statement: For any two vectors \vec{r}_1 and \vec{r}_2 in space $\vec{r}_1 + \vec{r}_2 = \vec{r}_2 + \vec{r}_1$.

Proof: Let $\vec{r}_1 = x_1\hat{i} + y_1\hat{j} + z_1\hat{k}$ and $\vec{r}_2 = x_2\hat{i} + y_2\hat{j} + z_2\hat{k}$

Thus
$$\begin{aligned} \vec{r}_1 + \vec{r}_2 &= (x_1\hat{i} + y_1\hat{j} + z_1\hat{k}) + (x_2\hat{i} + y_2\hat{j} + z_2\hat{k}) \\ &= (x_1 + x_2)\hat{i} + (y_1 + y_2)\hat{j} + (z_1 + z_2)\hat{k} \end{aligned}$$

Since $x_1, x_2, y_1, y_2, z_1, z_2 \in \mathbb{R}$ and commutative law w. r. t. addition holds in \mathbb{R} , so we may write

$$\begin{aligned} \vec{r}_1 + \vec{r}_2 &= (x_2 + x_1)\hat{i} + (y_2 + y_1)\hat{j} + (z_2 + z_1)\hat{k} \\ &= (x_2\hat{i} + y_2\hat{j} + z_2\hat{k}) + (x_1\hat{i} + y_1\hat{j} + z_1\hat{k}) \\ &= \vec{r}_2 + \vec{r}_1 \end{aligned}$$

Associative Law for Vector Addition

Statement: For any three vectors \vec{r}_1, \vec{r}_2 and \vec{r}_3 in space; $\vec{r}_1 + (\vec{r}_2 + \vec{r}_3) = (\vec{r}_1 + \vec{r}_2) + \vec{r}_3$

Proof: Let $\vec{r}_1 = x_1\hat{i} + y_1\hat{j} + z_1\hat{k}$, $\vec{r}_2 = x_2\hat{i} + y_2\hat{j} + z_2\hat{k}$ and $\vec{r}_3 = x_3\hat{i} + y_3\hat{j} + z_3\hat{k}$

$$\begin{aligned} \vec{r}_2 + \vec{r}_3 &= x_2\hat{i} + y_2\hat{j} + z_2\hat{k} + x_3\hat{i} + y_3\hat{j} + z_3\hat{k} \\ &= (x_2 + x_3)\hat{i} + (y_2 + y_3)\hat{j} + (z_2 + z_3)\hat{k} \\ \vec{r}_1 + (\vec{r}_2 + \vec{r}_3) &= x_1\hat{i} + y_1\hat{j} + z_1\hat{k} + [(x_2 + x_3)\hat{i} + (y_2 + y_3)\hat{j} + (z_2 + z_3)\hat{k}] \\ &= [x_1 + (x_2 + x_3)]\hat{i} + [y_1 + (y_2 + y_3)]\hat{j} + [z_1 + (z_2 + z_3)]\hat{k} \end{aligned}$$

Since $x_1, x_2, x_3, y_1, y_2, y_3, z_1, z_2, z_3 \in \mathbb{R}$ and associative law holds in \mathbb{R} w. r. t. addition so, we may write:

$$\begin{aligned} \vec{r}_1 + (\vec{r}_2 + \vec{r}_3) &= [(x_1 + x_2) + x_3]\hat{i} + [(y_1 + y_2) + y_3]\hat{j} + [(z_1 + z_2) + z_3]\hat{k} \\ &= [(x_1 + x_2)\hat{i} + (y_1 + y_2)\hat{j} + (z_1 + z_2)\hat{k}] + (x_3\hat{i} + y_3\hat{j} + z_3\hat{k}) \\ &= [(x_1\hat{i} + y_1\hat{j} + z_1\hat{k}) + (x_2\hat{i} + y_2\hat{j} + z_2\hat{k})] + (x_3\hat{i} + y_3\hat{j} + z_3\hat{k}) \\ &= (\vec{r}_1 + \vec{r}_2) + \vec{r}_3 \end{aligned}$$

3.3.2 Identity Vector for Addition

Let $\vec{0} = 0\hat{i} + 0\hat{j} + 0\hat{k}$ be the null vector and $\vec{r} = x\hat{i} + y\hat{j} + z\hat{k}$ be any vector in space. Now

$$\begin{aligned}\vec{0} + \vec{r} &= (0\hat{i} + 0\hat{j} + 0\hat{k}) + (x\hat{i} + y\hat{j} + z\hat{k}) \\ &= (0 + x)\hat{i} + (0 + y)\hat{j} + (0 + z)\hat{k}\end{aligned}$$

Since 0 is the additive identity of real numbers; so,

$$\vec{0} + \vec{r} = x\hat{i} + y\hat{j} + z\hat{k} = \vec{r}$$

Also

$$\begin{aligned}\vec{r} + \vec{0} &= (x\hat{i} + y\hat{j} + z\hat{k}) + (0\hat{i} + 0\hat{j} + 0\hat{k}) \\ &= (x + 0)\hat{i} + (y + 0)\hat{j} + (z + 0)\hat{k} \\ &= x\hat{i} + y\hat{j} + z\hat{k} = \vec{r}\end{aligned}$$

Therefore,

$$\vec{0} + \vec{r} = \vec{r} + \vec{0} = \vec{r}$$

This shows that $\vec{0}$ is the identity for the vector addition.

Additive Inverse in Vectors

Consider any vector $\vec{r} = x\hat{i} + y\hat{j} + z\hat{k}$ in space, then $-\vec{r} = (-x)\hat{i} + (-y)\hat{j} + (-z)\hat{k}$. Now

$$\begin{aligned}\vec{r} + (-\vec{r}) &= (x\hat{i} + y\hat{j} + z\hat{k}) + \{(-x)\hat{i} + (-y)\hat{j} + (-z)\hat{k}\} \\ &= (x + (-x))\hat{i} + (y + (-y))\hat{j} + (z + (-z))\hat{k} \\ &= 0\hat{i} + 0\hat{j} + 0\hat{k} \\ &= \vec{0}\end{aligned}$$

and

$$\begin{aligned}(-\vec{r}) + \vec{r} &= \{(-x)\hat{i} + (-y)\hat{j} + (-z)\hat{k}\} + (x\hat{i} + y\hat{j} + z\hat{k}) \\ &= ((-x) + x)\hat{i} + ((-y) + y)\hat{j} + ((-z) + z)\hat{k} \\ &= 0\hat{i} + 0\hat{j} + 0\hat{k} \\ &= \vec{0}\end{aligned}$$

Therefore,

$$\vec{r} + (-\vec{r}) = (-\vec{r}) + \vec{r} = \vec{0}$$

This shows that $-\vec{r}$ is the additive inverse of \vec{r} .

3.4 Properties of Scalar Multiplication

3.4.1 Commutative Law of Scalar Multiplication

Statement: For a scalar λ and a vector \vec{r} in space $\lambda\vec{r} = \vec{r}\lambda$.

Proof: Let $\vec{r} = x\hat{i} + y\hat{j} + z\hat{k}$ be a vector in space then:

$$\begin{aligned}\lambda\vec{r} &= \lambda(x\hat{i} + y\hat{j} + z\hat{k}) = (\lambda x)\hat{i} + (\lambda y)\hat{j} + (\lambda z)\hat{k} \\ &= (x\lambda)\hat{i} + (y\lambda)\hat{j} + (z\lambda)\hat{k} = (x\hat{i} + y\hat{j} + z\hat{k})\lambda \\ &= \vec{r}\lambda\end{aligned}$$

Associative Law of Scalar Multiplication

Statement: For any two scalars λ_1, λ_2 and a vector \vec{r} in space $\lambda_1(\lambda_2\vec{r}) = (\lambda_1\lambda_2)\vec{r}$.

Proof: Let $\vec{r} = x\hat{i} + y\hat{j} + z\hat{k}$ be a vector in space then

$$\begin{aligned}\lambda_2\vec{r} &= \lambda_2(x\hat{i} + y\hat{j} + z\hat{k}) = (\lambda_2x)\hat{i} + (\lambda_2y)\hat{j} + (\lambda_2z)\hat{k} \\ \lambda_1(\lambda_2\vec{r}) &= \lambda_1[(\lambda_2x)\hat{i} + (\lambda_2y)\hat{j} + (\lambda_2z)\hat{k}] = \lambda_1(\lambda_2x)\hat{i} + \lambda_1(\lambda_2y)\hat{j} + \lambda_1(\lambda_2z)\hat{k} \\ &= (\lambda_1\lambda_2)x\hat{i} + (\lambda_1\lambda_2)y\hat{j} + (\lambda_1\lambda_2)z\hat{k} = (\lambda_1\lambda_2)(x\hat{i} + y\hat{j} + z\hat{k}) = (\lambda_1\lambda_2)\vec{r}\end{aligned}$$

State and Prove Distributive Laws for Scalar Multiplication

Statement: For scalars λ_1, λ_2 and \vec{r}_1, \vec{r}_2 any two space vectors

$$(i) \quad (\lambda_1 + \lambda_2)\vec{r}_1 = \lambda_1\vec{r}_1 + \lambda_2\vec{r}_1$$

$$(ii) \quad \lambda_1(\vec{r}_1 + \vec{r}_2) = \lambda_1\vec{r}_1 + \lambda_1\vec{r}_2$$

Proof: Let $\vec{r}_1 = x_1\hat{i} + y_1\hat{j} + z_1\hat{k}$, and $\vec{r}_2 = x_2\hat{i} + y_2\hat{j} + z_2\hat{k}$ be two vectors in space.

$$(i) \quad (\lambda_1 + \lambda_2)\vec{r}_1 = (\lambda_1 + \lambda_2)(x_1\hat{i} + y_1\hat{j} + z_1\hat{k}) \\ = \{(\lambda_1 + \lambda_2)x_1\}\hat{i} + \{(\lambda_1 + \lambda_2)y_1\}\hat{j} + \{(\lambda_1 + \lambda_2)z_1\}\hat{k}$$

Since distributive law holds in \mathbb{R} ; so,

$$\begin{aligned} (\lambda_1 + \lambda_2)\vec{r}_1 &= (\lambda_1x_1 + \lambda_2x_1)\hat{i} + (\lambda_1y_1 + \lambda_2y_1)\hat{j} + (\lambda_1z_1 + \lambda_2z_1)\hat{k} \\ &= (\lambda_1x_1\hat{i} + \lambda_1y_1\hat{j} + \lambda_1z_1\hat{k}) + (\lambda_2x_1\hat{i} + \lambda_2y_1\hat{j} + \lambda_2z_1\hat{k}) \\ &= \lambda_1(x_1\hat{i} + y_1\hat{j} + z_1\hat{k}) + \lambda_2(x_1\hat{i} + y_1\hat{j} + z_1\hat{k}) \\ &= \lambda_1\vec{r}_1 + \lambda_2\vec{r}_1 \end{aligned}$$

$$(ii) \quad \lambda_1(\vec{r}_1 + \vec{r}_2) = \lambda_1[(x_1\hat{i} + y_1\hat{j} + z_1\hat{k}) + (x_2\hat{i} + y_2\hat{j} + z_2\hat{k})] \\ = \lambda_1[(x_1 + x_2)\hat{i} + (y_1 + y_2)\hat{j} + (z_1 + z_2)\hat{k}] \\ = \lambda_1(x_1 + x_2)\hat{i} + \lambda_1(y_1 + y_2)\hat{j} + \lambda_1(z_1 + z_2)\hat{k} \\ = [\lambda_1x_1\hat{i} + \lambda_1y_1\hat{j} + \lambda_1z_1\hat{k}] + [\lambda_1x_2\hat{i} + \lambda_1y_2\hat{j} + \lambda_1z_2\hat{k}] \\ = \lambda_1(x_1\hat{i} + y_1\hat{j} + z_1\hat{k}) + \lambda_1(x_2\hat{i} + y_2\hat{j} + z_2\hat{k}) \\ = \lambda_1\vec{r}_1 + \lambda_1\vec{r}_2$$

Distance Between the Two Points in \mathbb{R}^3 (Distance Formula)

Consider any two points $P(x_1, y_1, z_1)$ and $Q(x_2, y_2, z_2)$ in \mathbb{R}^3 .

The distance between P and Q is the magnitude of the vector \overline{PQ} .

The position vectors of P and Q are \overline{OP} and \overline{OQ} respectively; where

$$\overline{OP} = x_1\hat{i} + y_1\hat{j} + z_1\hat{k}$$

$$\text{and } \overline{OQ} = x_2\hat{i} + y_2\hat{j} + z_2\hat{k}$$

It is clear that:

$$\overline{OP} + \overline{PQ} = \overline{OQ}$$

$$\Rightarrow \overline{PQ} = \overline{OQ} - \overline{OP}$$

$$= (x_2\hat{i} + y_2\hat{j} + z_2\hat{k}) - (x_1\hat{i} + y_1\hat{j} + z_1\hat{k})$$

$$\Rightarrow \overline{PQ} = (x_2 - x_1)\hat{i} + (y_2 - y_1)\hat{j} + (z_2 - z_1)\hat{k}$$

$$\Rightarrow |\overline{PQ}| = \sqrt{(x_2 - x_1)^2 + (y_2 - y_1)^2 + (z_2 - z_1)^2}$$

Which is the distance between the points $P(x_1, y_1, z_1)$

and $Q(x_2, y_2, z_2)$.

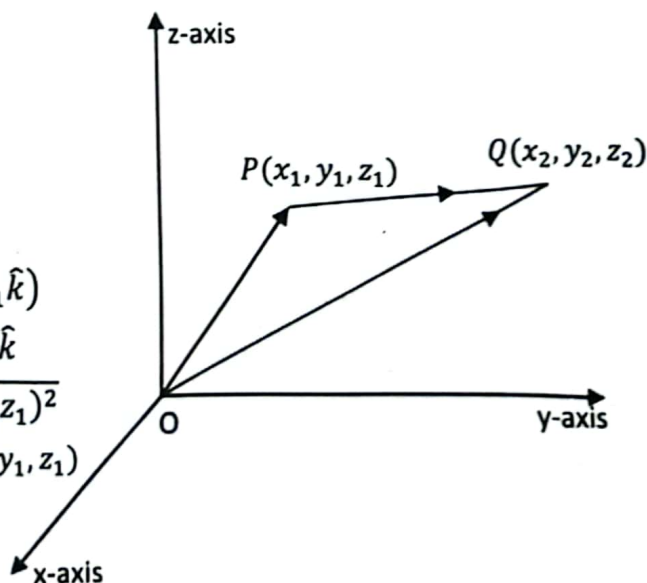

Exercise 3.1

- In the following find the required vector in its component form. Given that $P = (3, -1)$; $Q = (-4, -6)$; $R = (1, 4)$ and $S = (2, 5)$
 - \overrightarrow{PQ}
 - $3\overrightarrow{PQ} - \overrightarrow{RS}$
 - $2\overrightarrow{PR} + 3\overrightarrow{PS}$
 - $\frac{1}{2}\overrightarrow{PQ} + \frac{5}{2}\overrightarrow{PR} - \frac{3}{2}\overrightarrow{QS}$
 - $3^2\overrightarrow{PS} - 4^2\overrightarrow{SP} + \overrightarrow{QP}$
- Show that:
 - the points $A(1, 0)$; $B(6, 0)$ and $C(0, 0)$ are collinear.
 - if \vec{a} and \vec{b} are the position vectors of points $(2, -7)$ and $(\frac{m}{2}, 11)$, find the value of m for which \vec{a} and \vec{b} are collinear.
- If $\vec{u} = \langle -1, 1 \rangle$; $\vec{v} = \langle 0, 1 \rangle$ and $\vec{w} = \langle 3, 4 \rangle$ then
 - Find \vec{x} that satisfies $\vec{u} - 2\vec{x} = \vec{x} - \vec{w} + 3\vec{v}$ ($\langle x, y \rangle$ means $x\hat{i} + y\hat{j}$)
 - Find \vec{u} and \vec{v} if $\vec{u} + \vec{v} = \langle 2, -3 \rangle$; $3\vec{u} + 2\vec{v} = \langle -1, 2 \rangle$
 - Find initial point of $\vec{v} = \langle -3, 1, 2 \rangle$ if its terminal point is $(5, 0, 1)$.
- Find the value of m for which the vector $\vec{a} = 3\hat{i} + 4\hat{j} - 9\hat{k}$ is parallel to $\vec{b} = \hat{i} + m\hat{j} - 3\hat{k}$.
 - Find the value of λ for which the points P, Q and R are collinear.
Given that $\hat{i} + 2\hat{j} + 3\hat{k}$, $-2\hat{i} + 3\hat{j} + 5\hat{k}$ and $\lambda\hat{i} - \hat{k}$ are the position vectors of points P, Q and R respectively.
- If $\vec{a} = \hat{i} - 2\hat{j} + \hat{k}$; $\vec{b} = \hat{i} - \hat{j} - \hat{k}$ and $\vec{c} = 2\hat{i} + \hat{k}$ then find a unit vector in the direction of $2\vec{a} - 3\vec{b} + \vec{c}$.
 - Use vectors to find the length of diagonals of a parallelogram having adjacent sides $\hat{i} + \hat{j}$ and $\hat{i} - 2\hat{j}$.
- Show that the points with position vectors $\hat{i} - \hat{j}$, $4\hat{i} + 3\hat{j} + \hat{k}$ and $2\hat{i} - 4\hat{j} + 5\hat{k}$ are the vertices of a right-angled triangle.
 - Show that the points with position vectors $2\hat{i} + 3\hat{j} + \sqrt{3}\hat{k}$, $\sqrt{10}\hat{i} - \hat{j} + \sqrt{5}\hat{k}$ and $-3\hat{i} + \sqrt{3}\hat{j} + 2\hat{k}$ are the vertices of an equilateral triangle.
- Find the value of λ for which $|\vec{a}| = |3\vec{b}|$ where $\vec{a} = \hat{i} - 3\hat{j} + \lambda\hat{k}$ and $\vec{b} = \hat{i} + 2\hat{j} - \hat{k}$.
 - If $\vec{a} = 2\hat{i} + 3\hat{j}$ and $\vec{b} = -3\hat{i} + 2\hat{j}$. Check whether $|\vec{a}| = |\vec{b}|$ or $\vec{a} = \vec{b}$.
- If $\vec{a} = 2\hat{i} - 3\hat{j} + \hat{k}$ and $\vec{b} = \hat{i} - 3\hat{j} + 5\hat{k}$ then find:
 - A vector of magnitude 5 in the direction $\vec{a} - 2\vec{b}$.
 - A vector of magnitude $\frac{3}{7}$ opposite in direction $3\vec{a} + \vec{b}$.
- The position vectors of points A and B are $\hat{i} - 2\hat{j} + \hat{k}$ and $2\hat{i} + 3\hat{j} - \hat{k}$ respectively.
 - Find the position vector of point P dividing the line segment joining A and B in the ratio 2 : 3 internally.

- (ii) Find the position vector of point Q dividing the line segment \overline{AB} in the ratio 3 : 2 externally.
10. (i) The three vertices of a parallelogram ABCD taken in order are $A(3, -4)$; $B(-1, -3)$ and $C(-6, 2)$. Find the fourth vertex D.
- (ii) Find the values of x and y if $A(1, 2)$; $B(4, y)$; $C(x, 6)$ and $D(3, 5)$ taken in order are the vertices of a parallelogram.
11. Show that the line segments joining the mid points of the sides of a quadrilateral consecutively form a parallelogram.
12. Show that line segments joining the mid points of the diagonals and the mid points of any two opposite sides of a quadrilateral consecutively form a parallelogram.
13. Prove that line segments joining the midpoint of the diagonals of a trapezium is parallel to the parallel sides and its length is half the difference of the lengths of the parallel sides.
14. OPQR is a trapezium made from three equilateral triangles with $\overline{OP} = \vec{r}$, $\overline{OS} = \vec{s}$ and M is the midpoint of \overline{QR} .
- (i) Write \overline{PS} in terms of \vec{r} and \vec{s} .
- (ii) Show that \overline{OQ} is parallel to \overline{SM} .

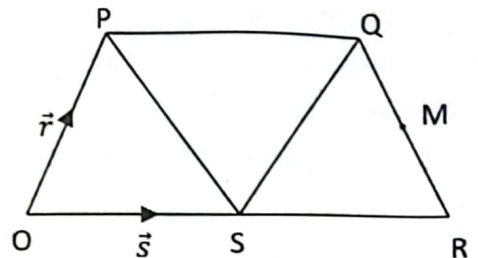

15. ABCD is a trapezium with \overline{AB} parallel to \overline{DC} . E is the point on the diagonal \overline{DB} such that $DE = \frac{1}{3}DB$. Show that \overline{BC} is parallel to \overline{AE} .

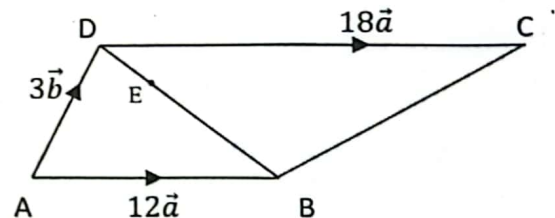

16. ABCDEF is a regular hexagon as shown in the figure. If $\overline{AB} = \vec{a}$ and $\overline{BC} = \vec{b}$, then express \overline{AC} , \overline{CD} , \overline{EF} , \overline{DA} , \overline{EB} , \overline{FA} and \overline{FC} in terms of \vec{a} and \vec{b} .

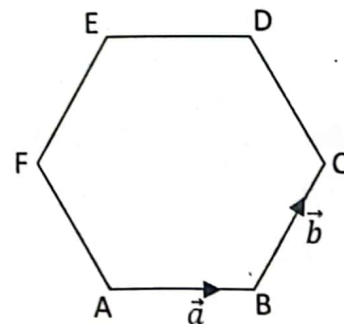

3.5 Dot or Scalar Product

3.5.1 Dot or Scalar Product of Two Vectors and its Geometrical Interpretation

If θ is the angle between the two non-zero vectors \vec{a} and \vec{b} then their dot product is denoted by $\vec{a} \cdot \vec{b}$ and is defined as:

$$\vec{a} \cdot \vec{b} = |\vec{a}| |\vec{b}| \cos \theta$$

where, θ is measured from \vec{a} to \vec{b} and $0^\circ \leq \theta \leq 180^\circ$.

θ is positive if measured in anticlockwise and is taken as negative if measured clockwise.

The value of dot product is a scalar quantity that's why it is known as scalar product.

Observe that:

$$\begin{aligned} \vec{b} \cdot \vec{a} &= |\vec{b}||\vec{a}| \cos(-\theta) \\ &= |\vec{b}||\vec{a}| \cos \theta \quad (\because \cos(-\theta) = \cos \theta) \\ &= |\vec{a}||\vec{b}| \cos \theta \\ &= \vec{a} \cdot \vec{b} \end{aligned}$$

i.e.; $\vec{a} \cdot \vec{b} = \vec{b} \cdot \vec{a}$

The reason for the angle to be taken $-\theta$ is that for $\vec{b} \cdot \vec{a}$ angle will be measured from \vec{b} to \vec{a} which is measured clockwise and therefore will be taken negative.

Particular Cases:

Case I: when $\theta = 90^\circ$ then vectors will be perpendicular or orthogonal to each other. In this case

$$\vec{a} \cdot \vec{b} = |\vec{a}||\vec{b}| \cos 90^\circ = |\vec{a}||\vec{b}|(0) = 0$$

Case II: When $\theta = 0^\circ$ then both the vectors have the same direction. i.e.; Both are parallel to each other, in this case

$$\vec{a} \cdot \vec{b} = |\vec{a}||\vec{b}| \cos 0^\circ = |\vec{a}||\vec{b}|(1) = |\vec{a}||\vec{b}|$$

Case III: When $\vec{a} = \vec{b}$ then in that case:

$$\begin{aligned} \vec{a} \cdot \vec{a} &= |\vec{a}||\vec{a}| \cos 0^\circ \\ &= |\vec{a}||\vec{a}|(1) \\ \vec{a} \cdot \vec{a} &= |\vec{a}|^2 \\ \Rightarrow |\vec{a}|^2 &= \sqrt{\vec{a} \cdot \vec{a}} \end{aligned}$$

3.5.2 Dot Product of Fundamental Unit Vectors \hat{i}, \hat{j} and \hat{k}

The fundamental unit vectors in \mathbb{R}^3 are \hat{i}, \hat{j} and \hat{k} .

\hat{i} is along x-axis; \hat{j} is along y-axis and \hat{k} is along z-axis. So $|\hat{i}| = 1; |\hat{j}| = 1$ and $|\hat{k}| = 1$. Now

$$\begin{aligned} \hat{i} \cdot \hat{i} &= |\hat{i}||\hat{i}| \cos 0^\circ = 1.1.1 = 1 \\ \hat{j} \cdot \hat{j} &= |\hat{j}||\hat{j}| \cos 0^\circ = 1.1.1 = 1 \\ \hat{k} \cdot \hat{k} &= |\hat{k}||\hat{k}| \cos 0^\circ = 1.1.1 = 1 \\ \hat{i} \cdot \hat{j} &= |\hat{i}||\hat{j}| \cos 90^\circ = 1.1.0 = 0 \\ \hat{j} \cdot \hat{k} &= |\hat{j}||\hat{k}| \cos 90^\circ = 1.1.0 = 0 \\ \hat{k} \cdot \hat{i} &= |\hat{k}||\hat{i}| \cos 90^\circ = 1.1.0 = 0 \end{aligned}$$

Also $\hat{j} \cdot \hat{i} = \hat{i} \cdot \hat{j} = 0$
 $\hat{k} \cdot \hat{j} = \hat{j} \cdot \hat{k} = 0$
 $\hat{i} \cdot \hat{k} = \hat{k} \cdot \hat{i} = 0$

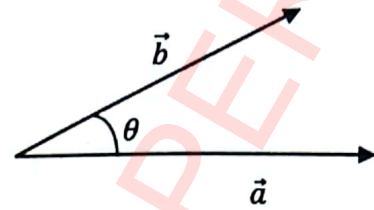

The angle between the vectors is the angle where the tail or head of both vectors meet.

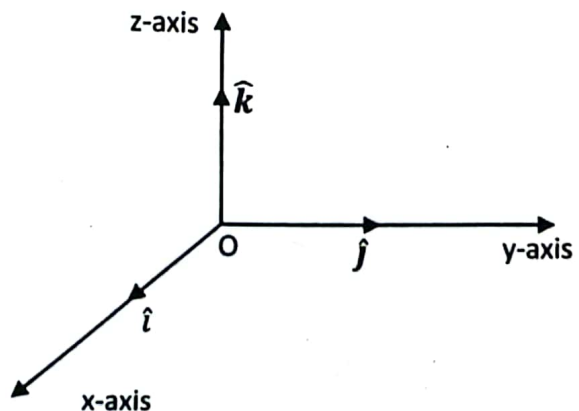

3.5.3 Dot Product in Terms of Components

Consider any two non-zero vectors \vec{a} and \vec{b} in space.

Let $\vec{a} = a_1\hat{i} + a_2\hat{j} + a_3\hat{k}$

and $\vec{b} = b_1\hat{i} + b_2\hat{j} + b_3\hat{k}$

Then
$$\begin{aligned}\vec{a} \cdot \vec{b} &= (a_1\hat{i} + a_2\hat{j} + a_3\hat{k}) \cdot (b_1\hat{i} + b_2\hat{j} + b_3\hat{k}) \\ &= (a_1\hat{i}) \cdot (b_1\hat{i}) + (a_1\hat{i}) \cdot (b_2\hat{j}) + (a_1\hat{i}) \cdot (b_3\hat{k}) + (a_2\hat{j}) \cdot (b_1\hat{i}) + (a_2\hat{j}) \cdot (b_2\hat{j}) \\ &\quad + (a_2\hat{j}) \cdot (b_3\hat{k}) + (a_3\hat{k}) \cdot (b_1\hat{i}) + (a_3\hat{k}) \cdot (b_2\hat{j}) + (a_3\hat{k}) \cdot (b_3\hat{k})\end{aligned}$$

Since the dot product is defined between the vectors, so,

$$\begin{aligned}\vec{a} \cdot \vec{b} &= a_1b_1(\hat{i} \cdot \hat{i}) + a_1b_2(\hat{i} \cdot \hat{j}) + a_1b_3(\hat{i} \cdot \hat{k}) + a_2b_1(\hat{j} \cdot \hat{i}) + a_2b_2(\hat{j} \cdot \hat{j}) + a_2b_3(\hat{j} \cdot \hat{k}) \\ &\quad + a_3b_1(\hat{k} \cdot \hat{i}) + a_3b_2(\hat{k} \cdot \hat{j}) + a_3b_3(\hat{k} \cdot \hat{k})\end{aligned}$$

$$\vec{a} \cdot \vec{b} = a_1b_1(1) + a_1b_2(0) + a_1b_3(0) + a_2b_1(0) + a_2b_2(1) + a_2b_3(0) + a_3b_1(0) + a_3b_2(0) + a_3b_3(1)$$

$$\vec{a} \cdot \vec{b} = a_1b_1 + a_2b_2 + a_3b_3$$

This is known as analytical expression for dot product.

3.5.4 Condition for Orthogonality of Two Vectors

Consider two non-zero vectors \vec{a} and \vec{b} in space. Let $\vec{a} = a_1\hat{i} + a_2\hat{j} + a_3\hat{k}$

and $\vec{b} = b_1\hat{i} + b_2\hat{j} + b_3\hat{k}$

\vec{a} and \vec{b} will be orthogonal (perpendicular) to each other if and only if $\vec{a} \cdot \vec{b} = 0$

$$\Rightarrow (a_1\hat{i} + a_2\hat{j} + a_3\hat{k}) \cdot (b_1\hat{i} + b_2\hat{j} + b_3\hat{k}) = 0$$

$$\Rightarrow a_1b_1 + a_2b_2 + a_3b_3 = 0$$

Which is the condition for the two vectors \vec{a} and \vec{b} to be orthogonal to each other.

3.5.5 Commutative Property of Dot Product

Statement: For any two vectors \vec{a} and \vec{b}

$$\vec{a} \cdot \vec{b} = \vec{b} \cdot \vec{a}$$

Proof: Let $\vec{a} = a_1\hat{i} + a_2\hat{j} + a_3\hat{k}$ and $\vec{b} = b_1\hat{i} + b_2\hat{j} + b_3\hat{k}$ be two vectors

$$\begin{aligned}\therefore \vec{a} \cdot \vec{b} &= (a_1\hat{i} + a_2\hat{j} + a_3\hat{k}) \cdot (b_1\hat{i} + b_2\hat{j} + b_3\hat{k}) \\ &= a_1b_1 + a_2b_2 + a_3b_3\end{aligned}$$

Since commutative law holds in \mathbb{R} , so

$$\begin{aligned}\vec{a} \cdot \vec{b} &= b_1a_1 + b_2a_2 + b_3a_3 \\ &= (b_1\hat{i} + b_2\hat{j} + b_3\hat{k}) \cdot (a_1\hat{i} + a_2\hat{j} + a_3\hat{k}) \\ \vec{a} \cdot \vec{b} &= \vec{b} \cdot \vec{a}\end{aligned}$$

Distributive Property of Dot Product

Statement: For any three vectors \vec{a} , \vec{b} and \vec{c}

$$\vec{a} \cdot (\vec{b} + \vec{c}) = \vec{a} \cdot \vec{b} + \vec{a} \cdot \vec{c}$$

Proof: Let

$$\vec{a} = a_1\hat{i} + a_2\hat{j} + a_3\hat{k}$$

$$\vec{b} = b_1\hat{i} + b_2\hat{j} + b_3\hat{k}$$

$$\vec{c} = c_1\hat{i} + c_2\hat{j} + c_3\hat{k}$$

Then

$$\begin{aligned} \vec{b} + \vec{c} &= (b_1\hat{i} + b_2\hat{j} + b_3\hat{k}) + (c_1\hat{i} + c_2\hat{j} + c_3\hat{k}) \\ &= (b_1 + c_1)\hat{i} + (b_2 + c_2)\hat{j} + (b_3 + c_3)\hat{k} \\ \Rightarrow \vec{a} \cdot (\vec{b} + \vec{c}) &= (a_1\hat{i} + a_2\hat{j} + a_3\hat{k}) \cdot [(b_1 + c_1)\hat{i} + (b_2 + c_2)\hat{j} + (b_3 + c_3)\hat{k}] \\ &= a_1(b_1 + c_1) + a_2(b_2 + c_2) + a_3(b_3 + c_3) \\ &= (a_1b_1 + a_1c_1) + (a_2b_2 + a_2c_2) + (a_3b_3 + a_3c_3) \\ &= (a_1b_1 + a_2b_2 + a_3b_3) + (a_1c_1 + a_2c_2 + a_3c_3) \\ &= \vec{a} \cdot \vec{b} + \vec{a} \cdot \vec{c} \end{aligned}$$

3.5.6 Direction Angles

The angles which a non-zero vector \vec{r} makes with the coordinate axes in the positive direction are known as direction angles of \vec{r} . Let these angles be α, β and γ ; then

$$0 \leq \alpha \leq \pi; \quad 0 \leq \beta \leq \pi; \quad 0 \leq \gamma \leq \pi$$

Direction Cosines

If α, β and γ be the direction angles of a non-zero vector \vec{r} with x-axis; y-axis and z-axis respectively, then $\cos \alpha, \cos \beta$ and $\cos \gamma$ are called the direction cosines of \vec{r} .

$$\text{Here } \vec{r} = \vec{OP} = x\hat{i} + y\hat{j} + z\hat{k}$$

$$|\vec{r}| = \sqrt{x^2 + y^2 + z^2}$$

From right-angled triangle AOP:

$$\frac{|\vec{OA}|}{|\vec{OP}|} = \cos \alpha \text{ or } \Rightarrow \boxed{\cos \alpha = \frac{x}{|\vec{r}|}}$$

From right-angled triangle BOP:

$$\frac{|\vec{OB}|}{|\vec{OP}|} = \cos \beta \text{ or } \Rightarrow \boxed{\cos \beta = \frac{y}{|\vec{r}|}}$$

From right-angled triangle COP:

$$\frac{|\vec{OC}|}{|\vec{OP}|} = \cos \gamma \text{ or } \Rightarrow \boxed{\cos \gamma = \frac{z}{|\vec{r}|}}$$

In literature $\cos \alpha, \cos \beta$ and $\cos \gamma$ are denoted by l, m and n respectively. i.e.;

$$\begin{aligned} l &= \cos \alpha = \frac{x}{|\vec{r}|} \\ m &= \cos \beta = \frac{y}{|\vec{r}|} \\ n &= \cos \gamma = \frac{z}{|\vec{r}|} \end{aligned}$$

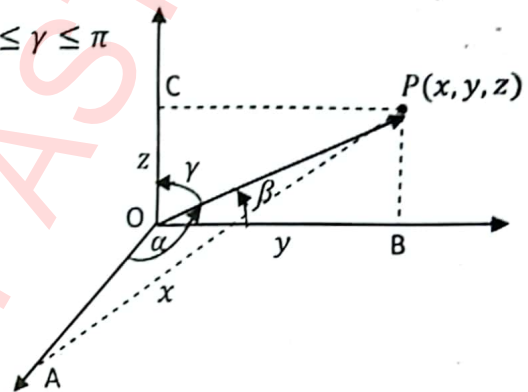

3.5.7 Sum of Squares of Direction Cosines is Unity

Let \vec{r} be a non-zero vector and α, β and γ be its direction angles. If

$$\vec{r} = x\hat{i} + y\hat{j} + z\hat{k}$$

Then

$$|\vec{r}| = \sqrt{x^2 + y^2 + z^2}$$

$$|\vec{r}|^2 = x^2 + y^2 + z^2$$

The direction cosines of \vec{r} are $\cos \alpha = \frac{x}{|\vec{r}|}$, $\cos \beta = \frac{y}{|\vec{r}|}$ and $\cos \gamma = \frac{z}{|\vec{r}|}$.

$$\begin{aligned} \text{Now } \cos^2 \alpha + \cos^2 \beta + \cos^2 \gamma &= \left(\frac{x}{|\vec{r}|}\right)^2 + \left(\frac{y}{|\vec{r}|}\right)^2 + \left(\frac{z}{|\vec{r}|}\right)^2 \\ &= \frac{x^2}{|\vec{r}|^2} + \frac{y^2}{|\vec{r}|^2} + \frac{z^2}{|\vec{r}|^2} = \frac{x^2 + y^2 + z^2}{|\vec{r}|^2} \\ &= \frac{|\vec{r}|^2}{|\vec{r}|^2} = 1 \end{aligned}$$

Hence

$$\cos^2 \alpha + \cos^2 \beta + \cos^2 \gamma = 1$$

\therefore Sum of squares of direction cosines is unity.

Deduction:

$$\text{Since } \cos^2 \alpha + \cos^2 \beta + \cos^2 \gamma = 1$$

$$\Rightarrow (1 - \sin^2 \alpha) + (1 - \sin^2 \beta) + (1 - \sin^2 \gamma) = 1$$

$$\Rightarrow 3 - \sin^2 \alpha - \sin^2 \beta - \sin^2 \gamma = 1$$

$$\Rightarrow \sin^2 \alpha + \sin^2 \beta + \sin^2 \gamma = 2$$

Direction Ratios

The numbers which are proportional to the direction cosines of a non-zero vector \vec{r} are known as direction ratios.

Let a, b and c be the numbers which are proportional to $\cos \alpha, \cos \beta$ and $\cos \gamma$. i.e.;

$$a \propto \cos \alpha; \quad b \propto \cos \beta; \quad c \propto \cos \gamma$$

$$\Rightarrow a = k \cos \alpha; \quad b = k \cos \beta; \quad c = k \cos \gamma$$

where K is constant of proportionality and $k \neq 0$

$$\begin{aligned} \Rightarrow a^2 + b^2 + c^2 &= k^2 \cos^2 \alpha + k^2 \cos^2 \beta + k^2 \cos^2 \gamma \\ &= k^2 (\cos^2 \alpha + \cos^2 \beta + \cos^2 \gamma) = k^2 \end{aligned}$$

$$\Rightarrow k = \pm \sqrt{a^2 + b^2 + c^2}$$

$$\therefore a = k \cos \alpha \Rightarrow \cos \alpha = \frac{a}{k}$$

$$\text{or } \cos \alpha = \pm \frac{a}{\sqrt{a^2 + b^2 + c^2}}$$

$$\therefore b = k \cos \beta \Rightarrow \cos \beta = \frac{b}{k}$$

$$\text{or } \cos \beta = \pm \frac{b}{\sqrt{a^2 + b^2 + c^2}}$$

- Direction ratios are also known as direction numbers or direction components.
- Sum of squares of direction ratios need not to be unity.

$$\because c = k \cos \gamma \Rightarrow \cos \gamma = \frac{c}{k}$$

$$\text{or } \cos \gamma = \pm \frac{c}{\sqrt{a^2 + b^2 + c^2}}$$

These relations are used to find direction cosines when its direction ratios are given.

Key Facts

Let $\vec{OP} = x\hat{i} + y\hat{j} + z\hat{k}$ be the position vector of a point $P(x, y, z)$.

If $\cos \alpha$, $\cos \beta$ and $\cos \gamma$ are its direction cosines then

$$\cos \alpha = \frac{x}{|\vec{r}|} \Rightarrow x = |\vec{r}| \cos \alpha$$

$$\cos \beta = \frac{y}{|\vec{r}|} \Rightarrow y = |\vec{r}| \cos \beta$$

$$\cos \gamma = \frac{z}{|\vec{r}|} \Rightarrow z = |\vec{r}| \cos \gamma$$

The coordinates of point P in the form of direction cosines can be written as:

$$(x, y, z) = (|\vec{r}| \cos \alpha, |\vec{r}| \cos \beta, |\vec{r}| \cos \gamma)$$

Example: Find the coordinates of point P , if \vec{OP} is a vector of magnitude 2 and is parallel to the vector $2\hat{i} - 3\hat{j} + 4\hat{k}$.

Solution:

$$\text{Let } \vec{a} = 2\hat{i} - 3\hat{j} + 4\hat{k}$$

$$\Rightarrow |\vec{a}| = \sqrt{(2)^2 + (-3)^2 + (4)^2} = \sqrt{4 + 9 + 16} = \sqrt{29}$$

$$\text{Thus } \hat{a} = \frac{\vec{a}}{|\vec{a}|} = \frac{2\hat{i} - 3\hat{j} + 4\hat{k}}{\sqrt{29}}$$

$$\hat{a} = \frac{2}{\sqrt{29}}\hat{i} - \frac{3}{\sqrt{29}}\hat{j} + \frac{4}{\sqrt{29}}\hat{k}$$

$$\text{As } \vec{OP} = 2\hat{a} = 2\left(\frac{2}{\sqrt{29}}\hat{i} - \frac{3}{\sqrt{29}}\hat{j} + \frac{4}{\sqrt{29}}\hat{k}\right)$$

$$\Rightarrow \vec{OP} = \frac{4}{\sqrt{29}}\hat{i} - \frac{6}{\sqrt{29}}\hat{j} + \frac{8}{\sqrt{29}}\hat{k}$$

$\therefore \left(\frac{4}{\sqrt{29}}, -\frac{6}{\sqrt{29}}, \frac{8}{\sqrt{29}}\right)$ are the coordinates of point P .

Example: Two direction angles of vector \vec{r} are 30° and 60° . Find the third direction angle. Also find unit vector \hat{r} .

Solution:

$$\text{Let } \alpha = 30^\circ \text{ and } \beta = 60^\circ$$

$$\text{Since } \cos^2 \alpha + \cos^2 \beta + \cos^2 \gamma = 1$$

$$\Rightarrow \cos^2 30^\circ + \cos^2 60^\circ + \cos^2 \gamma = 1$$

$$\Rightarrow \left(\frac{\sqrt{3}}{2}\right)^2 + \left(\frac{1}{2}\right)^2 + \cos^2 \gamma = 1$$

$$\Rightarrow \frac{3}{4} + \frac{1}{4} + \cos^2 \gamma = 1 \Rightarrow 1 + \cos^2 \gamma = 1 \Rightarrow \cos^2 \gamma = 0$$

$$\Rightarrow \cos \gamma = 0$$

$$\Rightarrow \gamma = 90^\circ \text{ or } 270^\circ$$

Since $0 \leq \gamma \leq 180^\circ$

So $\gamma = 90^\circ$

Unit vector of \vec{r} is:

$$\hat{r} = \cos \alpha \hat{i} + \cos \beta \hat{j} + \cos \gamma \hat{k}$$

$$\Rightarrow \hat{r} = \cos 30^\circ \hat{i} + \cos 60^\circ \hat{j} + \cos 90^\circ \hat{k}$$

$$\Rightarrow \hat{r} = \frac{\sqrt{3}}{2} \hat{i} + \frac{1}{2} \hat{j} + 0 \hat{k}$$

Which is the required unit vector.

3.5.8 Angle Between Two Non-Zero Vectors

Let θ be the angle between two non-zero vectors \vec{a} and \vec{b} .

Since $\vec{a} \cdot \vec{b} = |\vec{a}| |\vec{b}| \cos \theta$

$$\Rightarrow \cos \theta = \frac{\vec{a} \cdot \vec{b}}{|\vec{a}| |\vec{b}|}$$

$$\text{or } \theta = \cos^{-1} \left(\frac{\vec{a} \cdot \vec{b}}{|\vec{a}| |\vec{b}|} \right)$$

$$\theta = \cos^{-1} \left(\frac{\vec{a}}{|\vec{a}|} \cdot \frac{\vec{b}}{|\vec{b}|} \right)$$

$$\Rightarrow \theta = \cos^{-1}(\hat{a} \cdot \hat{b})$$

In component form we can write it as

$$\vec{a} = a_1 \hat{i} + a_2 \hat{j} + a_3 \hat{k}$$

$$\vec{b} = b_1 \hat{i} + b_2 \hat{j} + b_3 \hat{k}$$

Then $\vec{a} \cdot \vec{b} = (a_1 \hat{i} + a_2 \hat{j} + a_3 \hat{k}) \cdot (b_1 \hat{i} + b_2 \hat{j} + b_3 \hat{k}) = a_1 b_1 + a_2 b_2 + a_3 b_3$

$$|\vec{a}| = \sqrt{a_1^2 + a_2^2 + a_3^2}$$

$$|\vec{b}| = \sqrt{b_1^2 + b_2^2 + b_3^2}$$

Substituting values in the equation $\theta = \cos^{-1} \left(\frac{\vec{a} \cdot \vec{b}}{|\vec{a}| |\vec{b}|} \right)$, we have:

$$\theta = \cos^{-1} \left(\frac{a_1 b_1 + a_2 b_2 + a_3 b_3}{\sqrt{a_1^2 + a_2^2 + a_3^2} \sqrt{b_1^2 + b_2^2 + b_3^2}} \right)$$

Example: Find the angle between the vectors $\hat{i} - 2\hat{j} + \hat{k}$ and $2\hat{i} - 3\hat{j} + \hat{k}$.

Solution:

Let $\vec{a} = \hat{i} - 2\hat{j} + \hat{k}$ and $\vec{b} = 2\hat{i} - 3\hat{j} + \hat{k}$, then

$$\begin{aligned}\vec{a} \cdot \vec{b} &= (\hat{i} - 2\hat{j} + \hat{k}) \cdot (2\hat{i} - 3\hat{j} + \hat{k}) = (1)(2) + (-2)(-3) + (1)(1) \\ &= 2 + 6 + 1 = 9\end{aligned}$$

$$|\vec{a}| = \sqrt{1^2 + (-2)^2 + 1^2} = \sqrt{1 + 4 + 1} = \sqrt{6}$$

$$|\vec{b}| = \sqrt{2^2 + (-3)^2 + 1^2} = \sqrt{4 + 9 + 1} = \sqrt{14}$$

If θ is the angle between \vec{a} and \vec{b} then

$$\theta = \cos^{-1} \left(\frac{\vec{a} \cdot \vec{b}}{|\vec{a}| |\vec{b}|} \right)$$

$$\theta = \cos^{-1} \left(\frac{9}{\sqrt{6}\sqrt{14}} \right) = \cos^{-1} \left(\frac{9}{\sqrt{84}} \right)$$

$$\Rightarrow \theta = 10.89^\circ$$

3.5.9 Projection of a Vector Along Another Vector

Consider two non-zero vectors \vec{a} and \vec{b} and let θ be the angle between them.

$|\vec{OL}|$ is the projection of \vec{b} upon \vec{a} .

From right-angled triangle BOL;

$$\frac{|\vec{OL}|}{|\vec{OB}|} = \cos \theta$$

$$\begin{aligned}|\vec{OL}| &= |\vec{OB}| \cos \theta \\ &= |\vec{b}| \cos \theta \\ &= \frac{|\vec{a}| |\vec{b}| \cos \theta}{|\vec{a}|}\end{aligned}$$

$$|\vec{OL}| = \frac{\vec{a} \cdot \vec{b}}{|\vec{a}|}$$

$$\therefore \text{Projection of } \vec{b} \text{ along } \vec{a} = \frac{\vec{a} \cdot \vec{b}}{|\vec{a}|}$$

$$= \frac{\vec{a}}{|\vec{a}|} \cdot \vec{b}$$

$$= \hat{a} \cdot \vec{b} = \vec{b} \cdot \hat{a}$$

Projection of \vec{b} along $\vec{a} = \vec{b} \cdot \hat{a}$

Similarly, we can prove that:

Projection of \vec{a} along $\vec{b} = \frac{\vec{a} \cdot \vec{b}}{|\vec{b}|}$

Projection of \vec{a} along $\vec{b} = \hat{b} \cdot \vec{a}$

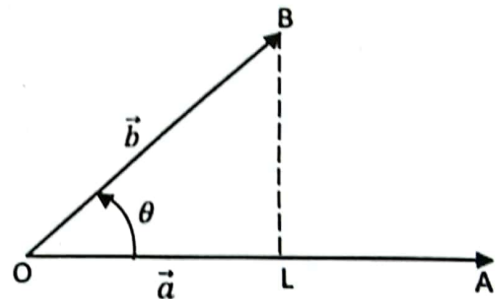

Example: If $\vec{a} = \hat{i} - \hat{j} + \hat{k}$ and $\vec{b} = -\hat{i} + \hat{j} + 3\hat{k}$, find projection of \vec{a} along \vec{b} and projection of \vec{b} along \vec{a} .

Solution:

$$\vec{a} \cdot \vec{b} = (\hat{i} - \hat{j} + \hat{k}) \cdot (-\hat{i} + \hat{j} + 3\hat{k})$$

$$= (1)(-1) + (-1)(1) + (1)(3) = -1 - 1 + 3 = 1$$

$$|\vec{a}| = \sqrt{(1)^2 + (-1)^2 + (1)^2} = \sqrt{3}$$

$$|\vec{b}| = \sqrt{(-1)^2 + (1)^2 + (3)^2} = \sqrt{11}$$

$$\text{Now projection of } \vec{a} \text{ along } \vec{b} = \frac{\vec{a} \cdot \vec{b}}{|\vec{b}|} = \frac{1}{\sqrt{11}}$$

$$\text{Projection of } \vec{b} \text{ along } \vec{a} = \frac{\vec{a} \cdot \vec{b}}{|\vec{a}|} = \frac{1}{\sqrt{3}}$$

Example: Prove that $\cos(\alpha - \beta) = \cos \alpha \cos \beta + \sin \alpha \sin \beta$

Solution:

Consider two-unit vectors $\hat{u} = \overrightarrow{OP}$ and $\hat{v} = \overrightarrow{OQ}$ making angles α and β with x-axis as shown in the figure. Thus

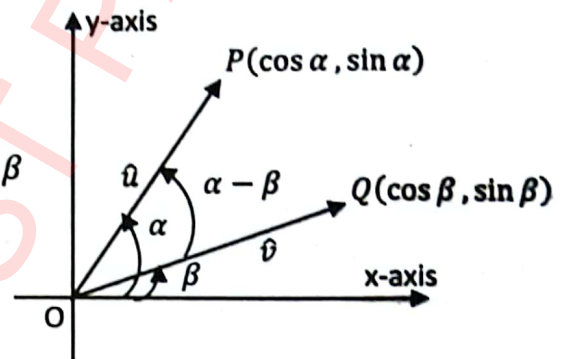

$\alpha - \beta$ is the angle between \hat{u} and \hat{v} . Since $\hat{u} = \overrightarrow{OP}$ is the position vector of point P so, $\hat{u} = \cos \alpha \hat{i} + \sin \alpha \hat{j}$. Similarly, $\hat{v} = \cos \beta \hat{i} + \sin \beta \hat{j}$

$$\text{Now, } \hat{u} \cdot \hat{v} = (\cos \alpha \hat{i} + \sin \alpha \hat{j}) \cdot (\cos \beta \hat{i} + \sin \beta \hat{j})$$

$$\hat{u} \cdot \hat{v} = \cos \alpha \cos \beta + \sin \alpha \sin \beta \tag{1}$$

$$\text{Also } \hat{u} \cdot \hat{v} = |\hat{u}| |\hat{v}| \cos(\alpha - \beta) = (1)(1) \cos(\alpha - \beta)$$

$$\hat{u} \cdot \hat{v} = \cos(\alpha - \beta) \tag{2}$$

From equation (1) and (2) we have:

$$\cos(\alpha - \beta) = \cos \alpha \cos \beta + \sin \alpha \sin \beta$$

Example: For any triangle ABC, with usual notations prove that $|\vec{a}| = |\vec{b}| \cos \gamma + |\vec{c}| \cos \beta$

Solution

Consider a triangle as shown in figure.

It is clear that

$$\vec{a} + \vec{b} + \vec{c} = 0$$

$$\Rightarrow \vec{a} = -\vec{b} - \vec{c}$$

Taking dot product with \vec{a} on both sides

$$\Rightarrow \vec{a} \cdot \vec{a} = \vec{a} \cdot (-\vec{b} - \vec{c})$$

$$\Rightarrow |\vec{a}|^2 = -\vec{a} \cdot \vec{b} - \vec{a} \cdot \vec{c}$$

$$= -|\vec{a}| |\vec{b}| \cos(180^\circ - \gamma) - |\vec{a}| |\vec{c}| \cos(180^\circ - \beta)$$

$$= -|\vec{a}| |\vec{b}| (-\cos \gamma) - |\vec{a}| |\vec{c}| (-\cos \beta) \quad \because \cos(180^\circ - \theta) = -\cos \theta$$

$$= |\vec{a}| |\vec{b}| \cos \gamma + |\vec{a}| |\vec{c}| \cos \beta$$

$$\Rightarrow |\vec{a}|^2 = |\vec{a}| (|\vec{b}| \cos \gamma + |\vec{c}| \cos \beta)$$

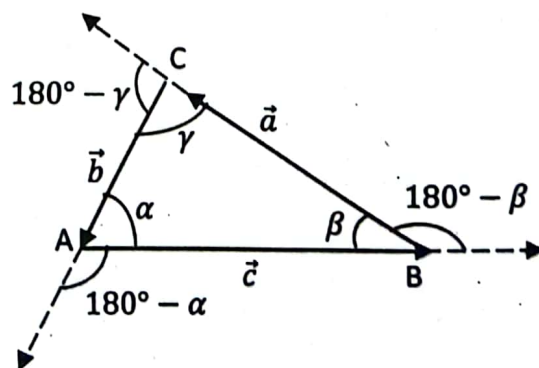

$$\Rightarrow |\vec{a}| = |\vec{b}| \cos \gamma + |\vec{c}| \cos \beta$$

3.5.10 Work Done by a Constant Force

Let a constant force is applied on an object and it is displaced from A to B.

The force \vec{F} makes an angle θ with the displacement vector \vec{S} .

The component of \vec{F} along \vec{S} is $|\vec{F}| \cos \theta$.

Thus work done by the force \vec{F} to move the object from A to B is:

$$\text{work done} = |\vec{F}| \cos \theta (|\vec{S}|) = |\vec{F}||\vec{S}| \cos \theta$$

$$\text{work done} = \vec{F} \cdot \vec{S}$$

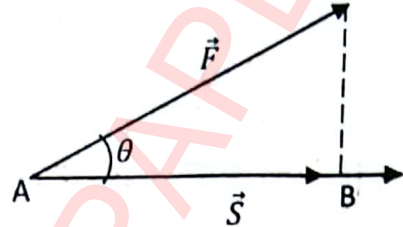

Example: Find the work done by a constant force $\vec{F} = 2\hat{i} + \hat{j} - \hat{k}$ in moving an object from $A(0,1,3)$ to $B(-1,2,4)$.

Solution:

$$\vec{F} = 2\hat{i} + \hat{j} - \hat{k}$$

$$\begin{aligned} \vec{S} &= \vec{AB} = (1-0)\hat{i} + (2-1)\hat{j} + (4-3)\hat{k} \\ &= \hat{i} + \hat{j} + \hat{k} \end{aligned}$$

$$\begin{aligned} \text{Work done} &= \vec{F} \cdot \vec{S} \\ &= (2\hat{i} + \hat{j} - \hat{k}) \cdot (\hat{i} + \hat{j} + \hat{k}) \\ &= (2)(1) + (1)(1) + (-1)(1) \\ &= 2 + 1 - 1 = 2 \text{ units} \end{aligned}$$

Exercise 3.2

- If $\vec{a} = 2\hat{i} - 3\hat{j} + \hat{k}$; $\vec{b} = \hat{i} - 3\hat{j} + 4\hat{k}$ and $\vec{c} = -\hat{i} - 2\hat{j} + 5\hat{k}$, then evaluate the followings.
 - $\vec{a} \cdot \vec{b}$
 - $2\vec{a} \cdot 3\vec{b}$
 - $(\vec{a} - \vec{b}) \cdot \vec{c}$
 - $(2\vec{a} + 3\vec{b} - \vec{c}) \cdot (\vec{a} + \vec{b})$
 - $\hat{i} \cdot \vec{a} + \hat{j} \cdot \vec{b} + \hat{k} \cdot \vec{c}$
- If $\vec{a} = \hat{j} - \hat{k}$; $\vec{b} = 3\hat{i} - 4\hat{j} + \hat{k}$ and $\vec{c} = -\hat{i} + 2\hat{j} - 4\hat{k}$, then find the angles between the vectors:
 - \vec{a} and $3\vec{b}$
 - $(2\vec{a} - 3\vec{b})$ and $2\vec{c}$
 - $(-\vec{a} + \vec{c})$ and $(\vec{b} - 2\vec{c})$
 - $(\vec{a} + \vec{b} + \vec{c})$ and $(\vec{a} - \vec{b} - \vec{c})$
 - $(\vec{a} - 2\vec{b} + \vec{c})$ and \vec{a}
- If \vec{a}, \vec{b} and \vec{c} are three vectors such that $\vec{a} + \vec{b} + \vec{c} = 0$ and $|\vec{a}| = 2$; $|\vec{b}| = 3$ and $|\vec{c}| = 4$ then find angle between \vec{a} and \vec{b} .
 - If $|\vec{a} + \vec{b}| = |\vec{a} - \vec{b}|$, then find angle between \vec{a} and \vec{b} .

4. (i) If $\vec{a} = \hat{i} - 3\hat{j} + 4\hat{k}$; $\vec{b} = 7\hat{i} - 9\hat{j} + \hat{k}$ and $\vec{c} = 3\hat{i} - 2\hat{j} + 5\hat{k}$, find the value of λ so that $\vec{a} - \lambda\vec{b}$ is perpendicular to \vec{c} .
- (ii) Show that the angle between any two diagonals of a cube is $\cos^{-1}\left(\frac{1}{3}\right)$.
5. (i) If $\vec{a} = 2\hat{i} - 3\hat{j} + 4\hat{k}$, then find the direction cosine of \vec{a} .
- (ii) If $\vec{a} = \hat{i} - 2\hat{j} + 3\hat{k}$; $\vec{b} = 3\hat{i} - 2\hat{j} + \hat{k}$ and $\vec{c} = 7\hat{i} - \hat{j} + 8\hat{k}$, then find the projection of $\vec{a} - \vec{b}$ along \vec{c} and projection of \vec{b} along $\vec{c} - \vec{a}$. Also find their vector projections.
6. (i) Three vertices of triangle are $A(0, -1, -2)$; $B(3, 1, 4)$ and $C(5, 7, 1)$. Show that ABC is a right-angled triangle and find the other two angles.
- (ii) A vector \vec{r} is equally inclined with the coordinate axes and $|\vec{r}| = 5$. Find the vector \vec{r} .
7. (i) If \vec{a}, \vec{b} and \vec{c} are three vectors such that $|\vec{a}| = 2$; $|\vec{b}| = 5$; $|\vec{c}| = 4$ and $\vec{a} + \vec{b} + \vec{c} = 0$ then find the value of $\vec{a} \cdot \vec{b} + \vec{b} \cdot \vec{c} + \vec{c} \cdot \vec{a}$
- (ii) For any vector \vec{r} prove that $\vec{r} = (\vec{r} \cdot \hat{i})\hat{i} + (\vec{r} \cdot \hat{j})\hat{j} + (\vec{r} \cdot \hat{k})\hat{k}$
8. The dot products of \vec{r} with the vectors $\hat{i} + \hat{j} - 3\hat{k}$; $\hat{i} + 3\hat{j} - 2\hat{k}$ and $2\hat{i} + \hat{j} + 4\hat{k}$ are 0, 5 and 8 respectively. Find the vector \vec{r} .
9. Prove that for any non-zero vectors \vec{a} and \vec{b} ;
- (i) $\vec{a} \cdot \vec{b} = \frac{1}{4}|\vec{a} + \vec{b}|^2 - \frac{1}{4}|\vec{a} - \vec{b}|^2$
- (ii) $|\vec{a}|^2 + |\vec{b}|^2 = \frac{1}{2}|\vec{a} + \vec{b}|^2 + \frac{1}{2}|\vec{a} - \vec{b}|^2$
10. (i) If the sum of two unit vectors is a unit vector, show that magnitude of their difference is $\sqrt{3}$.
- (ii) Show that angle in a semi-circle is a right angle.
11. (i) Prove that altitudes of a triangle are concurrent.
- (ii) Prove that angle bisectors of triangle are concurrent.
12. (i) Prove that $\cos(\alpha + \beta) = \cos \alpha \cos \beta - \sin \alpha \sin \beta$.
- (ii) With usual notations for a triangle ABC; prove that $c^2 = a^2 + b^2 - 2ab \cos \gamma$ and $b = a \cos \gamma + c \cos \alpha$
13. (i) The resultant of two vectors \vec{a} and \vec{b} is perpendicular to \vec{a} and $|\vec{a}| = \frac{1}{\sqrt{7}}|\vec{b}|$. Show that resultant of $7\vec{a}$ and \vec{b} is perpendicular to \vec{b} .
- (ii) Prove that $\vec{a} + \vec{b}$ is equally inclined with \vec{a} and \vec{b} .
14. A force of $\vec{F} = 3\hat{i} - 5\hat{j} + 7\hat{k}$ newtons is applied on a body and moves it at a distance of 14 meters in the direction of the vector $\hat{i} - 3\hat{j} + \hat{k}$. How much work is done?
15. Find the work done by the forces $2\hat{i} + 3\hat{j} - \hat{k}$ and $3\hat{i} + 7\hat{j} + 4\hat{k}$ acting on a particle in moving from point P to Q with position vectors $\hat{i} - 3\hat{j} + \frac{3}{2}\hat{k}$ and $2\hat{i} - \hat{j} + \frac{5}{2}\hat{k}$.
16. A box is dragged on the surface of a floor by a string that is applying a force of 30N at an angle of 30° with the floor. Find the work done by the force when the box is displaced up-to a distance of 10 meters.

3.6 Cross or Vector Product of Two Vectors

3.6.1 Cross or Vector Product of Two Vectors and its Geometrical Interpretation

If \vec{a} and \vec{b} are two non-zero vectors and θ is the angle between them, then their cross product is also a vector denoted by $\vec{a} \times \vec{b}$ and is defined as:

$$\vec{a} \times \vec{b} = |\vec{a}||\vec{b}| \sin \theta \hat{n}$$

where \hat{n} is a unit vector normal to the plane containing both the vectors \vec{a} and \vec{b} . θ is positive when measured anticlockwise and is negative when measured clockwise.

While computing $\vec{b} \times \vec{a}$ angle is measured from \vec{b} to \vec{a} which is the clockwise direction so;

$$\vec{b} \times \vec{a} = |\vec{b}||\vec{a}| \sin(-\theta) \hat{n}$$

Since $\sin(-\theta) = -\sin \theta$; then

$$\begin{aligned} \vec{b} \times \vec{a} &= -|\vec{b}||\vec{a}| \sin \theta \hat{n} \\ &= -\vec{a} \times \vec{b} \end{aligned}$$

This shows that $\vec{a} \times \vec{b}$ and $\vec{b} \times \vec{a}$ are opposite in direction.

Thus, $\vec{a} \times \vec{b} = -\vec{b} \times \vec{a}$

It means cross product is anti-commutative.

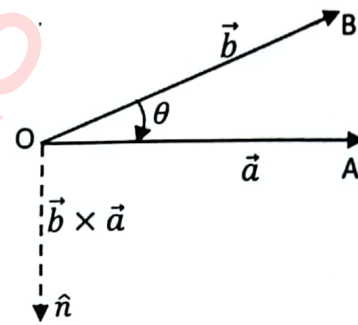
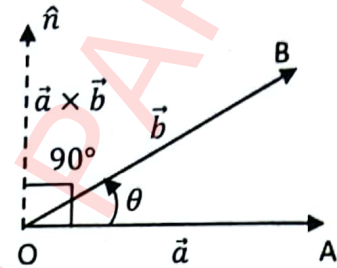

3.6.2 Cross Product of Fundamental Unit Vectors

We know that $\vec{a} \times \vec{b} = |\vec{a}||\vec{b}| \sin \theta \hat{n}$, so

$$\begin{aligned} \hat{i} \times \hat{i} &= |\hat{i}||\hat{i}| \sin 0^\circ \hat{n} \\ &= (1)(1)(0)\hat{n} = \vec{0} \end{aligned}$$

$$\begin{aligned} \hat{j} \times \hat{j} &= |\hat{j}||\hat{j}| \sin 0^\circ \hat{n} \\ &= (1)(1)(0)\hat{n} = \vec{0} \end{aligned}$$

$$\begin{aligned} \hat{k} \times \hat{k} &= |\hat{k}||\hat{k}| \sin 0^\circ \hat{n} \\ &= (1)(1)(0)\hat{n} = \vec{0} \end{aligned}$$

We know that \hat{i}, \hat{j} and \hat{k} are the mutually perpendicular unit vectors so,

$$\begin{aligned} \hat{i} \times \hat{j} &= |\hat{i}||\hat{j}| \sin 90^\circ \hat{k} \\ &= (1)(1)(1)\hat{k} = \hat{k} \end{aligned}$$

$$\begin{aligned} \hat{j} \times \hat{k} &= |\hat{j}||\hat{k}| \sin 90^\circ \hat{i} \\ &= (1)(1)(1)\hat{i} = \hat{i} \end{aligned}$$

$$\hat{k} \times \hat{i} = |\hat{k}||\hat{i}| \sin 90^\circ \hat{j}$$

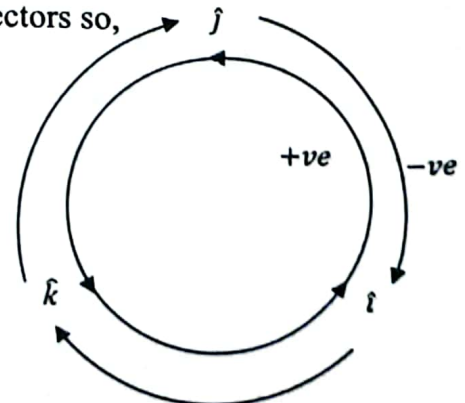
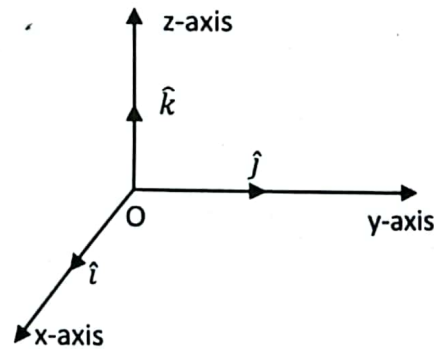

$$= (1)(1)(1)j = j$$

Also $j \times i = -i \times j = -k$

$$k \times j = -j \times k = -i$$

and $i \times k = -k \times i = -j$

Key Facts

The cross product is defined only for the vector in 3-space; whereas dot product is defined for vector both in 2-space and 3-space.



3.6.3 Cross Product in Terms of its Components

Consider two non-zero vectors \vec{a} and \vec{b} , where,

$$\vec{a} = a_1\hat{i} + a_2\hat{j} + a_3\hat{k}$$

and

$$\vec{b} = b_1\hat{i} + b_2\hat{j} + b_3\hat{k}$$

Now

$$\begin{aligned} \vec{a} \times \vec{b} &= (a_1\hat{i} + a_2\hat{j} + a_3\hat{k}) \times (b_1\hat{i} + b_2\hat{j} + b_3\hat{k}) \\ &= (a_1b_1)(\hat{i} \times \hat{i}) + (a_1b_2)(\hat{i} \times \hat{j}) + (a_1b_3)(\hat{i} \times \hat{k}) + (a_2b_1)(\hat{j} \times \hat{i}) + \\ &\quad (a_2b_2)(\hat{j} \times \hat{j}) + (a_2b_3)(\hat{j} \times \hat{k}) + (a_3b_1)(\hat{k} \times \hat{i}) + (a_3b_2)(\hat{k} \times \hat{j}) + \\ &\quad (a_3b_3)(\hat{k} \times \hat{k}) \\ &= (a_1b_1)(\vec{0}) + (a_1b_2)(\hat{k}) + (a_1b_3)(-\hat{j}) + (a_2b_1)(-\hat{k}) + (a_2b_2)(\vec{0}) \\ &\quad + (a_2b_3)(\hat{i}) + (a_3b_1)(\hat{j}) + (a_3b_2)(-\hat{i}) + (a_3b_3)(\vec{0}) \end{aligned}$$

$$\vec{a} \times \vec{b} = (a_1b_2)\hat{k} - (a_1b_3)\hat{j} - (a_2b_1)\hat{k} + (a_2b_3)\hat{i} + (a_3b_1)\hat{j} - (a_3b_2)\hat{i}$$

$$\vec{a} \times \vec{b} = (a_2b_3 - a_3b_2)\hat{i} - (a_1b_3 - a_3b_1)\hat{j} + (a_1b_2 - a_2b_1)\hat{k}$$

Which is cross product in component form. Also cross product can be written as:

$$\vec{a} \times \vec{b} = \begin{vmatrix} \hat{i} & \hat{j} & \hat{k} \\ a_1 & a_2 & a_3 \\ b_1 & b_2 & b_3 \end{vmatrix}$$

3.6.4 Area of Parallelogram

Consider a parallelogram ABCD.

Let $\vec{AB} = \vec{a}$ and $\vec{AD} = \vec{b}$ be the two adjacent sides of the parallelogram and θ is the angle between them.

From figure it is clear that area of the parallelogram ABCD is same as that of the area of rectangle EFCD.

From right-angled triangle EAD,

$$\frac{|ED|}{|AD|} = \sin \theta \Rightarrow \frac{|ED|}{|\vec{b}|} = \sin \theta$$

$$\Rightarrow |ED| = |\vec{b}| \sin \theta$$

Area of parallelogram ABCD = Area of rectangle EFCD

$$= |\vec{EF}| |ED| = |\vec{DC}| |ED|$$

$$= |\vec{a}| |\vec{b}| \sin \theta \quad (1)$$

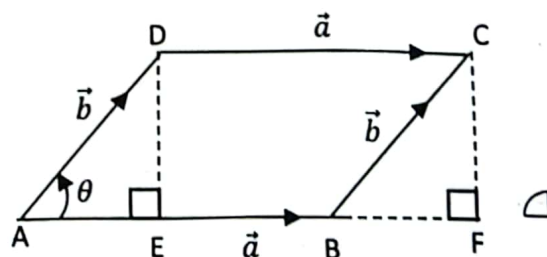

Also $\vec{a} \times \vec{b} = |\vec{a}||\vec{b}| \sin \theta \hat{n}$
 $|\vec{a} \times \vec{b}| = |\vec{a}||\vec{b}| \sin \theta |\hat{n}|$
 $= |\vec{a}||\vec{b}| \sin \theta$ (2)

From equations (1) and (2):

$$|\vec{a} \times \vec{b}| = \text{area of parallelogram ABCD}$$



If \vec{a} and \vec{b} are two adjacent sides of a triangle ABC then

$$\text{Area of triangle ABC} = \frac{1}{2} \text{Area of parallelogram ABDC}$$

$$\text{Area of triangle ABC} = \frac{1}{2} |\vec{a} \times \vec{b}|$$

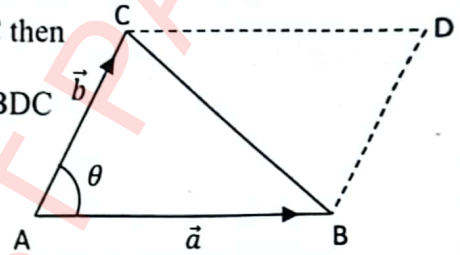

Example: If $\vec{a} = 2\hat{i} + 5\hat{j} - 2\hat{k}$ and $\vec{b} = \hat{i} - \hat{j} + 3\hat{k}$ are two adjacent sides of a parallelogram, then find its area.

Solution:

$$\vec{a} \times \vec{b} = \begin{vmatrix} \hat{i} & \hat{j} & \hat{k} \\ 2 & 5 & -2 \\ 1 & -1 & 3 \end{vmatrix}$$

$$= (15 - 2)\hat{i} - (6 + 2)\hat{j} + (-2 - 5)\hat{k}$$

$$\vec{a} \times \vec{b} = 13\hat{i} - 8\hat{j} - 7\hat{k}$$

$$|\vec{a} \times \vec{b}| = \sqrt{13^2 + (-8)^2 + (-7)^2}$$

$$= \sqrt{169 + 64 + 49} = \sqrt{282}$$

$$\text{Area of parallelogram} = |\vec{a} \times \vec{b}|$$

$$= \sqrt{282} \text{ sq. units}$$

Example: Find the area of a triangle with vertices $(0, 0)$, $(2, 9)$, $(3, 5)$.

Solution:

Let $A = (0, 0)$; $B = (2, 9)$ and $C = (3, 5)$

Then $\vec{a} = \vec{AC}$; $\vec{b} = \vec{AB}$

$$\text{So } \vec{a} = (3 - 0)\hat{i} + (5 - 0)\hat{j} = 3\hat{i} + 5\hat{j} + 0\hat{k}$$

$$\vec{b} = (2 - 0)\hat{i} + (9 - 0)\hat{j} = 2\hat{i} + 9\hat{j} + 0\hat{k}$$

$$\vec{a} \times \vec{b} = \begin{vmatrix} \hat{i} & \hat{j} & \hat{k} \\ 3 & 5 & 0 \\ 2 & 9 & 0 \end{vmatrix}$$

$$\vec{a} \times \vec{b} = (0 - 0)\hat{i} + (0 - 0)\hat{j} + (27 - 10)\hat{k}$$

$$\vec{a} \times \vec{b} = 0\hat{i} + 0\hat{j} + 17\hat{k}$$

$$|\vec{a} \times \vec{b}| = \sqrt{0^2 + 0^2 + 17^2} = 17$$

$$\text{Area of the triangle} = \frac{1}{2} |\vec{a} \times \vec{b}| = \frac{1}{2} (17) = \frac{17}{2} \text{ sq units}$$

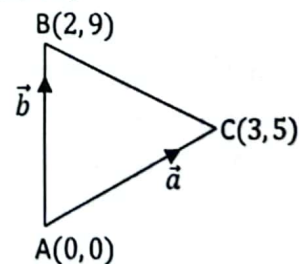

3.6.5 Condition for the Two Non-Zero Vectors to be Parallel

Let \vec{a} and \vec{b} are two non-zero vectors. If \vec{a} and \vec{b} are parallel then angle between the vectors is $\theta = 0^\circ$. So

$$\vec{a} \times \vec{b} = |\vec{a}||\vec{b}| \sin 0^\circ \hat{n} = |\vec{a}||\vec{b}|(0)\hat{n} = \vec{0}$$

Also, if \vec{a} and \vec{b} are anti-parallel then angle between the vectors is $\theta = 180^\circ$. So

$$\vec{a} \times \vec{b} = |\vec{a}||\vec{b}| \sin 180^\circ \hat{n} = |\vec{a}||\vec{b}|(0)\hat{n} = \vec{0}$$

Thus, if two non-zero vectors are parallel or anti-parallel then the value of their cross product is zero vector.

3.6.6 Distributive Law of Cross Product

If \vec{a}, \vec{b} and \vec{c} are any three vectors then:

$$(i) \vec{a} \times (\vec{b} + \vec{c}) = \vec{a} \times \vec{b} + \vec{a} \times \vec{c}$$

$$(ii) (\vec{a} + \vec{b}) \times \vec{c} = \vec{a} \times \vec{c} + \vec{b} \times \vec{c}$$

Proof: Let $\vec{a} = a_1\hat{i} + a_2\hat{j} + a_3\hat{k}$

$$\vec{b} = b_1\hat{i} + b_2\hat{j} + b_3\hat{k}$$

$$\vec{c} = c_1\hat{i} + c_2\hat{j} + c_3\hat{k}$$

$$\begin{aligned} \text{Then } \vec{b} + \vec{c} &= (b_1\hat{i} + b_2\hat{j} + b_3\hat{k}) + (c_1\hat{i} + c_2\hat{j} + c_3\hat{k}) \\ &= (b_1 + c_1)\hat{i} + (b_2 + c_2)\hat{j} + (b_3 + c_3)\hat{k} \end{aligned}$$

$$\begin{aligned} \text{LHS} = \vec{a} \times (\vec{b} + \vec{c}) &= \begin{vmatrix} \hat{i} & \hat{j} & \hat{k} \\ a_1 & a_2 & a_3 \\ b_1 + c_1 & b_2 + c_2 & b_3 + c_3 \end{vmatrix} \\ &= \begin{vmatrix} \hat{i} & \hat{j} & \hat{k} \\ a_1 & a_2 & a_3 \\ b_1 & b_2 & b_3 \end{vmatrix} + \begin{vmatrix} \hat{i} & \hat{j} & \hat{k} \\ a_1 & a_2 & a_3 \\ c_1 & c_2 & c_3 \end{vmatrix} \\ &= \vec{a} \times \vec{b} + \vec{a} \times \vec{c} \\ &= \text{RHS} \end{aligned}$$

Similarly, we can prove $(\vec{a} + \vec{b}) \times \vec{c} = \vec{a} \times \vec{c} + \vec{b} \times \vec{c}$

3.6.7 Angle Between Two Vectors

If θ is the angle between the non-zero vectors \vec{a} and \vec{b} then:

$$\vec{a} \times \vec{b} = |\vec{a}||\vec{b}| \sin \theta \hat{n}$$

$$\Rightarrow |\vec{a} \times \vec{b}| = |\vec{a}||\vec{b}| |\sin \theta| |\hat{n}|$$

$$\Rightarrow |\vec{a} \times \vec{b}| = |\vec{a}||\vec{b}| \sin \theta$$

$$(\because 0 \leq \theta \leq \pi \text{ so } |\sin \theta| = \sin \theta)$$

$$\Rightarrow \sin \theta = \frac{|\vec{a} \times \vec{b}|}{|\vec{a}||\vec{b}|}$$

$$\Rightarrow \theta = \sin^{-1} \left(\frac{|\vec{a} \times \vec{b}|}{|\vec{a}||\vec{b}|} \right)$$

Example: If $\vec{a} = 2\hat{i} - \hat{j} + \hat{k}$; $\vec{b} = -\hat{i} + 2\hat{j} - \hat{k}$ and $\vec{c} = \hat{i} + \hat{j} - 3\hat{k}$ then find the angle between the vectors $\vec{a} + \vec{b}$ and $\vec{a} + \vec{c}$.

Solution:

$$\vec{a} + \vec{b} = (2\hat{i} - \hat{j} + \hat{k}) + (-\hat{i} + 2\hat{j} - \hat{k}) = \hat{i} + \hat{j} + 0\hat{k}$$

and

$$\vec{a} + \vec{c} = (2\hat{i} - \hat{j} + \hat{k}) + (\hat{i} + \hat{j} - 3\hat{k}) = 3\hat{i} + 0\hat{j} - 2\hat{k}$$

now

$$\begin{aligned} (\vec{a} + \vec{b}) \times (\vec{a} + \vec{c}) &= \begin{vmatrix} \hat{i} & \hat{j} & \hat{k} \\ 1 & 1 & 0 \\ 3 & 0 & -2 \end{vmatrix} \\ &= (-2 - 0)\hat{i} - (-2 - 0)\hat{j} + (0 - 3)\hat{k} \\ &= -2\hat{i} + 2\hat{j} - 3\hat{k} \end{aligned}$$

$$\begin{aligned} |(\vec{a} + \vec{b}) \times (\vec{a} + \vec{c})| &= \sqrt{(-2)^2 + (2)^2 + (-3)^2} \\ &= \sqrt{4 + 4 + 9} = \sqrt{17} \end{aligned}$$

$$|\vec{a} + \vec{b}| = \sqrt{1^2 + 1^2 + 0^2} = \sqrt{2}$$

$$|\vec{a} + \vec{c}| = \sqrt{3^2 + 0^2 + (-2)^2} = \sqrt{13}$$

Let θ be the angle between $\vec{a} + \vec{b}$ and $\vec{a} + \vec{c}$; then

$$\sin \theta = \frac{|(\vec{a} + \vec{b}) \times (\vec{a} + \vec{c})|}{|\vec{a} + \vec{b}| |\vec{a} + \vec{c}|}$$

$$\sin \theta = \frac{\sqrt{17}}{\sqrt{2}\sqrt{13}} = \sqrt{\frac{17}{26}}$$

$$\Rightarrow \theta = \sin^{-1} \left(\sqrt{\frac{17}{26}} \right) = 53.96^\circ$$

Example: Show that $\sin(\alpha - \beta) = \sin \alpha \cos \beta - \cos \alpha \sin \beta$.

Solution:

Consider two unit vectors $\hat{u} = \overrightarrow{OA}$ and $\hat{v} = \overrightarrow{OB}$ making angles α and β with x -axis respectively. Then $\alpha - \beta$ is the angle between \hat{u} and \hat{v} .

$$\therefore \hat{u} = \overrightarrow{OA} = \cos \alpha \hat{i} + \sin \alpha \hat{j}$$

$$\hat{v} = \overrightarrow{OB} = \cos \beta \hat{i} + \sin \beta \hat{j}$$

$$\begin{aligned} \text{Now } \hat{v} \times \hat{u} &= \begin{vmatrix} \hat{i} & \hat{j} & \hat{k} \\ \cos \beta & \sin \beta & 0 \\ \cos \alpha & \sin \alpha & 0 \end{vmatrix} \\ &= (0 - 0)\hat{i} - (0 - 0)\hat{j} + (\sin \alpha \cos \beta - \cos \alpha \sin \beta)\hat{k} \\ &= 0\hat{i} - 0\hat{j} + (\sin \alpha \cos \beta - \cos \alpha \sin \beta)\hat{k} \end{aligned}$$

$$\begin{aligned} \Rightarrow |\hat{v} \times \hat{u}| &= \sqrt{0^2 + 0^2 + (\sin \alpha \cos \beta - \cos \alpha \sin \beta)^2} \\ &= (\sin \alpha \cos \beta - \cos \alpha \sin \beta) \end{aligned}$$

$$\text{Also } \hat{v} \times \hat{u} = |\hat{v}| |\hat{u}| \sin(\alpha - \beta) \hat{n}$$

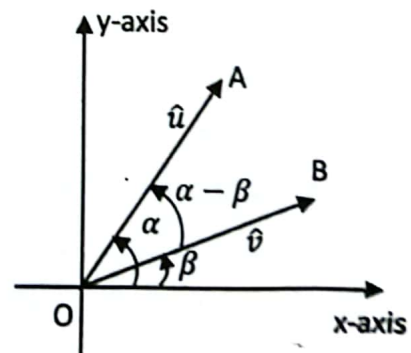

(1)

$$\Rightarrow \hat{v} \times \hat{u} = (1)(1)|\sin(\alpha - \beta)||\hat{n}|$$

$$\Rightarrow \hat{v} \times \hat{u} = \sin(\alpha - \beta) \tag{2}$$

From equation (1) and (2) we find that

$$\sin(\alpha - \beta) = \sin \alpha \cos \beta - \cos \alpha \sin \beta$$

3.6.8 Moment or Torque of a Given Force About a Given Point

The moment of a force is the turning effect of the force about a point, and is the product of the force and d ; where d is the perpendicular distance of the point from the line of action of the force.

From figure, moment of the force \vec{F} acting at point P about point O is

$$\text{Moment} = |OA| |\vec{F}|$$

From the right-triangle OPA;

$$\frac{|OA|}{|OP|} = \sin \theta; \text{ where } \theta \text{ is the angle between } \vec{r} \text{ and } \vec{F}.$$

$$\Rightarrow \frac{|OA|}{|\vec{r}|} = \sin \theta$$

$$\Rightarrow |OA| = |\vec{r}| \sin \theta$$

$$\text{Thus, moment} = (|\vec{r}| \sin \theta) |\vec{F}|$$

$$= |\vec{r}| |\vec{F}| \sin \theta$$

$$\text{Moment} = \vec{r} \times \vec{F}$$

The vector $\vec{M} = \vec{r} \times \vec{F}$, is called vector moment of the force \vec{F} .

Example: Find the moment of the force $\vec{F} = 3\hat{i} - 2\hat{j} + 5\hat{k}$ about the point $(2, 1, -1)$ when it is applied at point $(3, 0, 2)$.

Solution:

$$\text{Here } \vec{F} = 3\hat{i} - 2\hat{j} + 5\hat{k}$$

$$O = (2, 1, -1)$$

$$P = (3, 0, 2)$$

$$\vec{r} = \vec{OP} = (3 - 2)\hat{i} + (0 - 1)\hat{j} + (2 + 1)\hat{k}$$

$$= \hat{i} - \hat{j} + 3\hat{k}$$

$$\text{Vector moment} = \vec{r} \times \vec{F}$$

$$\vec{M} = \begin{vmatrix} \hat{i} & \hat{j} & \hat{k} \\ 1 & -1 & 3 \\ 3 & -2 & 5 \end{vmatrix}$$

$$= (-5 + 6)\hat{i} - (5 - 9)\hat{j} + (-2 + 3)\hat{k}$$

$$\vec{M} = \hat{i} + 4\hat{j} + \hat{k}$$

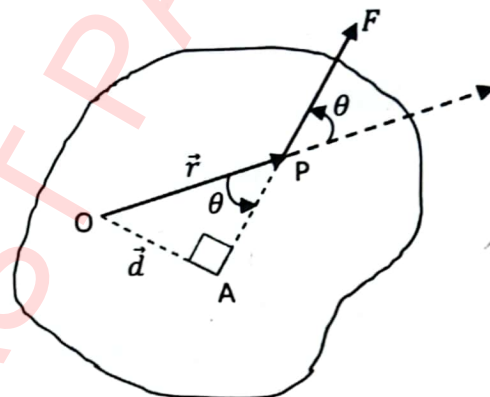

Example: Find the moment of the force $\vec{F} = 7\hat{i} + 4\hat{j} + 2\hat{k}$ when it is applied at the handle of a door at the point (2, 1, 4) about the hinge at point (0, 0, 1).

Solution:

Here $\vec{F} = 7\hat{i} + 4\hat{j} + 2\hat{k}$

$O = (0, 0, 1)$

$H = (2, 1, 4)$

$$\begin{aligned}\vec{r} &= \vec{OH} = (2 - 0)\hat{i} + (1 - 0)\hat{j} + (4 - 1)\hat{k} \\ &= 2\hat{i} + \hat{j} + 3\hat{k}\end{aligned}$$

Vector moment $= \vec{r} \times \vec{F}$

$$\vec{M} = \begin{vmatrix} \hat{i} & \hat{j} & \hat{k} \\ 2 & 1 & 3 \\ 7 & 4 & 2 \end{vmatrix}$$

$$= (2 - 12)\hat{i} - (4 - 21)\hat{j} + (8 - 7)\hat{k}$$

$$\vec{M} = -10\hat{i} + 17\hat{j} + \hat{k}$$

Is the required moment which is produced in the door.

Exercise 3.3

- For the following vectors, find $\vec{a} \times \vec{b}$ and $\vec{b} \times \vec{a}$ and prove that $\vec{a} \times \vec{b} = -\vec{b} \times \vec{a}$.
 - $\vec{a} = 2\hat{i} + \hat{j} - \hat{k}$; $\vec{b} = \hat{i} - 3\hat{j} + 7\hat{k}$
 - $\vec{a} = 7\hat{i} + 3\hat{j} + 9\hat{k}$; $\vec{b} = 2\hat{i} - 3\hat{j} + \hat{k}$
 - $\vec{a} = \hat{i} - 2\hat{k}$; $\vec{b} = 3\hat{i} + 2\hat{j}$
- For the following vectors, find $\vec{a} \times \vec{b}$ and prove that $\vec{a} \times \vec{b}$ is perpendicular to both \vec{a} and \vec{b} .
 - $\vec{a} = 3\hat{i} - 6\hat{j} + 2\hat{k}$; $\vec{b} = 2\hat{i} - 3\hat{j} + 4\hat{k}$
 - $\vec{a} = 4\hat{i} - 2\hat{j} + 3\hat{k}$; $\vec{b} = \hat{i} + \hat{j} - 3\hat{k}$
- For the following vectors, find the value of the sine of the angle between them.
 - $\vec{a} = 2\hat{i} - 4\hat{j} + 3\hat{k}$; $\vec{b} = \hat{i} - 3\hat{j} + 4\hat{k}$
 - $\vec{a} = 4\hat{i} - 3\hat{j} + 2\hat{k}$; $\vec{b} = 3\hat{i} - 7\hat{j} + 5\hat{k}$
- Find a vector of magnitude 5 and perpendicular to both the vectors $\vec{a} = 3\hat{i} - 2\hat{j} + 5\hat{k}$ and $\vec{b} = 8\hat{i} - 2\hat{j} + \hat{k}$.
 - Express the vector $5\hat{i} + 2\hat{j} - 3\hat{k}$ as a sum of two vectors one of which is parallel and other is perpendicular to the vector $2\hat{i} - \hat{j} + 3\hat{k}$.
- Prove the Lagrange identity $|\vec{a} \times \vec{b}|^2 = |\vec{a}|^2|\vec{b}|^2 - (\vec{a} \cdot \vec{b})^2$
 - For the vectors $\vec{a} = \hat{i} - 2\hat{j}$, $\vec{b} = 2\hat{i} + \hat{k}$ and $\vec{c} = 3\hat{j} + 2\hat{k}$, find a vector \vec{d} which is perpendicular to both \vec{a} and \vec{b} . It is given that $\vec{c} \cdot \vec{d} = 1$.

6. (i) Find the vector \vec{b} such that $\vec{a} \times \vec{b} = \vec{c}$ and $\vec{a} \cdot \vec{b} = 3$; where $\vec{a} = \hat{i} - 2\hat{j} + 3\hat{k}$ and $\vec{c} = \hat{i} + \hat{j} - \hat{k}$.
- (ii) If $\vec{a} \times \vec{b} = \vec{c} \times \vec{d}$ and $\vec{a} \times \vec{c} = \vec{b} \times \vec{d}$, show that $\vec{a} - \vec{d}$ is parallel to $\vec{b} - \vec{c}$; where $\vec{a} \neq \vec{d}$ and $\vec{b} \neq \vec{c}$.
7. (i) For a non-zero vector \vec{a} if $\vec{a} \cdot \vec{b} = \vec{a} \cdot \vec{c}$ and $\vec{a} \times \vec{b} = \vec{a} \times \vec{c}$ then show that $\vec{b} = \vec{c}$.
- (ii) For three vectors \vec{a}, \vec{b} and \vec{c} if $\vec{a} + \vec{b} + \vec{c} = \vec{0}$, then prove that:

$$\vec{a} \times \vec{b} = \vec{b} \times \vec{c} = \vec{c} \times \vec{a}$$
8. (i) If \vec{a}, \vec{b} and \vec{c} are three unit vectors such that \vec{a} is perpendicular to both \vec{b} and \vec{c} and the angle between \vec{b} and \vec{c} is $\frac{\pi}{3}$, then prove that $\vec{a} = \pm 2(\vec{b} \times \vec{c})$.
- (ii) Prove that $|\vec{a} \times \vec{b}|^2 = \begin{vmatrix} \vec{a} \cdot \vec{a} & \vec{a} \cdot \vec{b} \\ \vec{a} \cdot \vec{b} & \vec{b} \cdot \vec{b} \end{vmatrix}$
9. (i) If $|\vec{a}| = 3$; $|\vec{b}| = 5$ and $\vec{a} \cdot \vec{b} = 60$ then find $|\vec{a} \times \vec{b}|$.
- (ii) If $|\vec{a}| = 2$; $|\vec{b}| = 5$ and $|\vec{a} \times \vec{b}| = 8$ then find $\vec{a} \cdot \vec{b}$.
10. (i) Find the area of a parallelogram if $\vec{a} = 2\hat{i} - 3\hat{j} + \hat{k}$ and $\vec{b} = \hat{i} - 2\hat{j} + 7\hat{k}$ are its two adjacent sides.
- (ii) Find the area of triangle with vertices $(1, -1, 1)$; $(2, 1, 2)$ and $(3, 0, -1)$. Also find its interior angles.
11. (i) Find the area of the parallelogram having diagonals $3\hat{i} + \hat{j} - 2\hat{k}$ and $\hat{i} - 3\hat{j} + 4\hat{k}$.
- (ii) If \vec{a}, \vec{b} and \vec{c} are the position vectors of A, B and C respectively, then show that area of triangle ABC is $\frac{1}{2}|\vec{a} \times \vec{b} + \vec{b} \times \vec{c} + \vec{c} \times \vec{a}|$.
12. If $\vec{a} \cdot \vec{b} = 0$ and $\vec{a} \times \vec{b} = \vec{0}$, then what conclusion can be drawn about \vec{a} and \vec{b} .
13. Show that the three points with position vectors $\vec{a} - \vec{b} + 3\vec{c}$, $2\vec{a} + 3\vec{b} - 4\vec{c}$ and $-7\vec{b} + 10\vec{c}$ are collinear.
14. (i) Find the moment of force $2\hat{i} + 3\hat{j} + 7\hat{k}$ about the point $(1, 2, 3)$ when applied at the point $(-1, 2, 0)$.
- (ii) Two forces $2\hat{i} - \hat{j} + 3\hat{k}$ and $3\hat{i} + 4\hat{j} - 2\hat{k}$ are applied at the same point $(1, -2, 4)$. Find the moment of these concurrent forces about $(0, 0, 0)$.
15. (i) How much force is required to produce a moment of magnitude $\sqrt{57} \text{ N.m}$ along the direction $6\hat{i} - 21\hat{j} - 6\hat{k}$ when applied at $(2, 1, -3)$ about $(-1, -1, 1)$.
- (ii) At what point the force $2\hat{i} + 2\hat{j} - 3\hat{k}$ should be applied to produce a vector moment $\vec{M} = 3\hat{i} - 2\hat{j} + \hat{k}$ about $(-1, 2, -3)$.
16. A toy car is located at a point $(2, 3, 5)$ relative to origin, such that when a force of $3\hat{i} + 2\hat{j} + 7\hat{k}$ is applied on car it starts rotating about the origin. Find the moment produced by the force in the car.

17. A seesaw is fixed from its middle point which is at (0, 2, 3). Two forces $F_1[3, 4, 5]$ and $F_2[9, 2, 7]$ are applied at points (4, 5, 3) and (-4, -1, 3) respectively. Calculate the moment produced by each force about the fixed point in seesaw separately. Also find net moment.

3.7 Scalar Triple Product

3.7.1 Scalar Triple Product of Vectors

The scalar product of two vectors in which one vector is already a cross product of two vectors is called scalar triple product. If one vector is \vec{a} and other is $\vec{b} \times \vec{c}$, then their scalar triple product is $\vec{a} \cdot (\vec{b} \times \vec{c})$. It is also denoted by $[\vec{a} \vec{b} \vec{c}]$.

3.7.2 Determinant Form of Scalar Triple Product

Consider the vectors \vec{a}, \vec{b} and \vec{c} such that:

$$\vec{a} = a_1\hat{i} + a_2\hat{j} + a_3\hat{k}$$

$$\vec{b} = b_1\hat{i} + b_2\hat{j} + b_3\hat{k}$$

$$\vec{c} = c_1\hat{i} + c_2\hat{j} + c_3\hat{k}$$

$$\vec{b} \times \vec{c} = \begin{vmatrix} \hat{i} & \hat{j} & \hat{k} \\ b_1 & b_2 & b_3 \\ c_1 & c_2 & c_3 \end{vmatrix}$$

$$\vec{b} \times \vec{c} = (b_2c_3 - b_3c_2)\hat{i} - (b_1c_3 - b_3c_1)\hat{j} + (b_1c_2 - b_2c_1)\hat{k}$$

Therefore,

$$\begin{aligned} \vec{a} \cdot (\vec{b} \times \vec{c}) &= (a_1\hat{i} + a_2\hat{j} + a_3\hat{k}) \cdot [(b_2c_3 - b_3c_2)\hat{i} - (b_1c_3 - b_3c_1)\hat{j} + (b_1c_2 - b_2c_1)\hat{k}] \\ &= a_1(b_2c_3 - b_3c_2) - a_2(b_1c_3 - b_3c_1) + a_3(b_1c_2 - b_2c_1) \end{aligned}$$

$$\vec{a} \cdot (\vec{b} \times \vec{c}) = \begin{vmatrix} a_1 & a_2 & a_3 \\ b_1 & b_2 & b_3 \\ c_1 & c_2 & c_3 \end{vmatrix}$$

If any two vectors in the scalar product are same or parallel then the two rows of the determinant will be same, then the value of the determinant is zero. i.e, $\vec{a} \cdot \vec{b} \times \vec{c} = 0$

If we interchange any two vectors in the scalar triple product then the corresponding rows of the determinant will be interchanged producing the value of new scalar triple product as a negative multiple of the original product.

$$\vec{a} \cdot \vec{b} \times \vec{c} = -\vec{b} \cdot \vec{a} \times \vec{c} = -\vec{a} \cdot \vec{c} \times \vec{b} \text{ etc.}$$

3.7.3 Scalar Triple Product of \hat{i}, \hat{j} and \hat{k} Vectors

$$\hat{i} \cdot \hat{j} \times \hat{k} = \hat{i} \cdot \hat{i} = 1$$

$$\hat{j} \cdot \hat{k} \times \hat{i} = \hat{j} \cdot \hat{j} = 1$$

Key Facts

$(\vec{a} \cdot \vec{b}) \times \vec{c}$ is meaningless, because $\vec{a} \cdot \vec{b}$ is a scalar and will not have cross product with \vec{c} . Thus, there should be no confusion in writing $\vec{a} \cdot (\vec{b} \times \vec{c})$ as $\vec{a} \cdot \vec{b} \times \vec{c}$.

Thus $\hat{k} \cdot \hat{i} \times \hat{j} = \hat{k} \cdot \hat{k} = 1$
 Also $\hat{i} \cdot \hat{j} \times \hat{k} = \hat{j} \cdot \hat{k} \times \hat{i} = \hat{k} \cdot \hat{i} \times \hat{j} = 1$

$\hat{i} \cdot \hat{k} \times \hat{j} = \hat{i} \cdot (-\hat{i}) = -(\hat{i} \cdot \hat{i}) = -1$
 $\hat{j} \cdot \hat{i} \times \hat{k} = \hat{j} \cdot (-\hat{j}) = -(\hat{j} \cdot \hat{j}) = -1$
 $\hat{k} \cdot \hat{j} \times \hat{i} = \hat{k} \cdot (-\hat{k}) = -(\hat{k} \cdot \hat{k}) = -1$
 Thus $\hat{i} \cdot \hat{k} \times \hat{j} = \hat{j} \cdot \hat{i} \times \hat{k} = \hat{k} \cdot \hat{j} \times \hat{i} = -1$

Similarly,

$\hat{i} \cdot \hat{j} \times \hat{j} = \hat{i} \cdot (\vec{0}) = 0$
 $\hat{j} \cdot \hat{k} \times \hat{j} = \hat{j} \cdot (-\hat{i}) = -(\hat{j} \cdot \hat{i}) = 0$ etc.



Key Facts
 When any two vectors are same the value of their scalar triple product is zero.

3.7.4 Dot and Cross are Interchangeable in Scalar Triple Product

Here we will prove that the cross and dot product in the scalar triple product are interchangeable.

i.e, $\vec{a} \cdot \vec{b} \times \vec{c} = \vec{a} \times \vec{b} \cdot \vec{c}$

For this let

$\vec{a} = a_1\hat{i} + a_2\hat{j} + a_3\hat{k}$
 $\vec{b} = b_1\hat{i} + b_2\hat{j} + b_3\hat{k}$
 $\vec{c} = c_1\hat{i} + c_2\hat{j} + c_3\hat{k}$

As already proved that

$\vec{a} \cdot \vec{b} \times \vec{c} = \begin{vmatrix} a_1 & a_2 & a_3 \\ b_1 & b_2 & b_3 \\ c_1 & c_2 & c_3 \end{vmatrix}$ (1)

Now $\vec{a} \times \vec{b} = \begin{vmatrix} \hat{i} & \hat{j} & \hat{k} \\ a_1 & a_2 & a_3 \\ b_1 & b_2 & b_3 \end{vmatrix}$

$\vec{a} \times \vec{b} = (a_2b_3 - a_3b_2)\hat{i} - (a_1b_3 - a_3b_1)\hat{j} + (a_1b_2 - a_2b_1)\hat{k}$
 $(\vec{a} \times \vec{b}) \cdot \vec{c} = [(a_2b_3 - a_3b_2)\hat{i} - (a_1b_3 - a_3b_1)\hat{j} + (a_1b_2 - a_2b_1)\hat{k}] \cdot (c_1\hat{i} + c_2\hat{j} + c_3\hat{k})$
 $(\vec{a} \times \vec{b}) \cdot \vec{c} = (a_2b_3 - a_3b_2)c_1 - (a_1b_3 - a_3b_1)c_2 + (a_1b_2 - a_2b_1)c_3$
 $(\vec{a} \times \vec{b}) \cdot \vec{c} = a_2b_3c_1 - a_3b_2c_1 - a_1b_3c_2 + a_3b_1c_2 + a_1b_2c_3 - a_2b_1c_3$
 $(\vec{a} \times \vec{b}) \cdot \vec{c} = (a_1b_2c_3 - a_1b_3c_2) - (a_2b_1c_3 - a_2b_3c_1) + (a_3b_1c_2 - a_3b_2c_1)$
 $(\vec{a} \times \vec{b}) \cdot \vec{c} = a_1(b_2c_3 - b_3c_2) - a_2(b_1c_3 - b_3c_1) + a_3(b_1c_2 - b_2c_1)$

$\vec{a} \times \vec{b} \cdot \vec{c} = \begin{vmatrix} a_1 & a_2 & a_3 \\ b_1 & b_2 & b_3 \\ c_1 & c_2 & c_3 \end{vmatrix}$ (2)

From (1) and (2) it is clear that:

$\vec{a} \cdot \vec{b} \times \vec{c} = \vec{a} \times \vec{b} \cdot \vec{c}$

Example: If $\vec{a} = 2\hat{i} - 3\hat{j} + \hat{k}$; $\vec{b} = -3\hat{i} + 2\hat{j} + 3\hat{k}$ and $\vec{c} = -\hat{i} + \hat{j} - \hat{k}$, find $\vec{a} \cdot \vec{b} \times \vec{c}$.

Solution:

Since
$$\vec{a} \cdot \vec{b} \times \vec{c} = \begin{vmatrix} a_1 & a_2 & a_3 \\ b_1 & b_2 & b_3 \\ c_1 & c_2 & c_3 \end{vmatrix}$$

Then
$$\vec{a} \cdot \vec{b} \times \vec{c} = \begin{vmatrix} 2 & -3 & 1 \\ -3 & 2 & 3 \\ -1 & 1 & -1 \end{vmatrix}$$

$$\vec{a} \cdot \vec{b} \times \vec{c} = 2(-2 - 3) + 3(3 + 3) + 1(-3 + 2)$$

$$= -10 + 18 - 1$$

$$\vec{a} \cdot \vec{b} \times \vec{c} = 7$$

Example: Let we have three vectors \vec{a} , \vec{b} and \vec{c} such that \vec{b} is parallel to \vec{c} . Compute $\vec{a} \cdot \vec{b} \times \vec{c}$.

Solution:

Let
$$\vec{a} = a_1\hat{i} + a_2\hat{j} + a_3\hat{k}$$

$$\vec{b} = b_1\hat{i} + b_2\hat{j} + b_3\hat{k}$$

$$\vec{c} = c_1\hat{i} + c_2\hat{j} + c_3\hat{k}$$

Given that \vec{b} and \vec{c} are parallel; so

$$\vec{b} = \lambda\vec{c} \text{ for some scalar } \lambda.$$

$$b_1\hat{i} + b_2\hat{j} + b_3\hat{k} = \lambda(c_1\hat{i} + c_2\hat{j} + c_3\hat{k}) = (\lambda c_1)\hat{i} + (\lambda c_2)\hat{j} + (\lambda c_3)\hat{k}$$

$$\Rightarrow \boxed{b_1 = \lambda c_1}; \quad \boxed{b_2 = \lambda c_2}; \quad \boxed{b_3 = \lambda c_3}.$$

Now
$$\vec{a} \cdot \vec{b} \times \vec{c} = \begin{vmatrix} a_1 & a_2 & a_3 \\ b_1 & b_2 & b_3 \\ c_1 & c_2 & c_3 \end{vmatrix}$$

$$\vec{a} \cdot \vec{b} \times \vec{c} = \begin{vmatrix} a_1 & a_2 & a_3 \\ \lambda c_1 & \lambda c_2 & \lambda c_3 \\ c_1 & c_2 & c_3 \end{vmatrix} = \lambda \begin{vmatrix} a_1 & a_2 & a_3 \\ c_1 & c_2 & c_3 \\ c_1 & c_2 & c_3 \end{vmatrix}$$

$$\vec{a} \cdot \vec{b} \times \vec{c} = \lambda(0) = 0$$

($\because R_2$ & R_3 are identical)

3.7.5 Volume of Parallelepiped and a Tetrahedron

Volume of a Parallelepiped

Consider a parallelepiped with adjacent sides as \vec{a} , \vec{b} and \vec{c} .

Volume of the parallelepiped

$$= (\text{area of base})(\text{perpendicular height})$$

$$= |\vec{a} \times \vec{b}| \cdot |\overline{OD}| \quad (1)$$

$\vec{a} \times \vec{b}$ is the vector perpendicular

to both \vec{a} and \vec{b} . So \overline{OD} is in the direction

of $\vec{a} \times \vec{b}$.

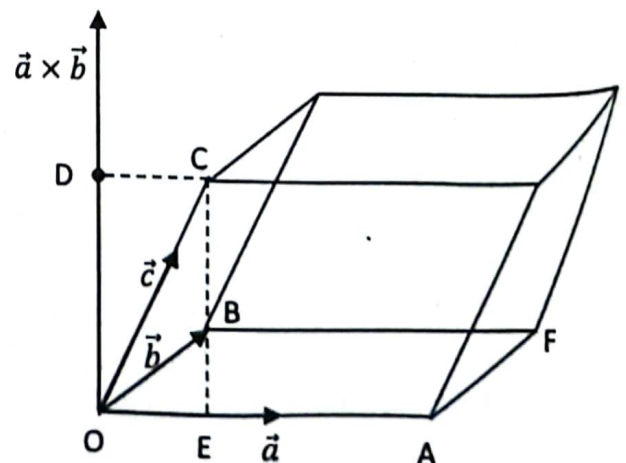

$|\overline{OD}|$ is the projection of \vec{c} along $\vec{a} \times \vec{b}$. Therefore

$$|\overline{OD}| = \frac{(\vec{a} \times \vec{b}) \cdot \vec{c}}{|\vec{a} \times \vec{b}|} = \frac{\vec{a} \cdot \vec{b} \times \vec{c}}{|\vec{a} \times \vec{b}|}$$

Putting in equation (1), we get:

$$\begin{aligned} \therefore \text{Volume of parallelepiped} &= |\vec{a} \times \vec{b}| \left(\frac{\vec{a} \cdot \vec{b} \times \vec{c}}{|\vec{a} \times \vec{b}|} \right) \\ &= \vec{a} \cdot \vec{b} \times \vec{c} \end{aligned}$$

Volume of Tetrahedron

Consider a tetrahedron with its three coterminal edges \vec{a} , \vec{b} and \vec{c} .

Volume of tetrahedron

$$= \frac{1}{3} (\text{area of base})(\text{perpendicular height})$$

$$= \frac{1}{3} (\text{area of triangle OAB})(|\overline{OD}|)$$

$$= \frac{1}{3} \left(\frac{1}{2} |\vec{a} \times \vec{b}| \right) (|\overline{OD}|)$$

$$= \frac{1}{6} |\vec{a} \times \vec{b}| |\overline{OD}|$$

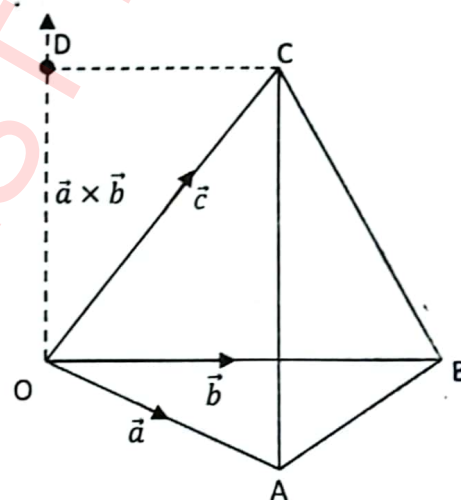

(1)

$\vec{a} \times \vec{b}$ is perpendicular to both \vec{a} and \vec{b} . So $|\overline{OD}|$ is in the direction of $\vec{a} \times \vec{b}$.

Also $|\overline{OD}|$ is the projection of \vec{c} on $\vec{a} \times \vec{b}$. Therefore

$$|\overline{OD}| = \frac{(\vec{a} \times \vec{b}) \cdot \vec{c}}{|\vec{a} \times \vec{b}|} = \frac{\vec{a} \cdot \vec{b} \times \vec{c}}{|\vec{a} \times \vec{b}|}$$

Putting value in equation (1), we get:

$$\therefore \text{Volume of tetrahedron} = \frac{1}{6} |\vec{a} \times \vec{b}| \frac{\vec{a} \cdot \vec{b} \times \vec{c}}{|\vec{a} \times \vec{b}|} = \frac{1}{6} (\vec{a} \cdot \vec{b} \times \vec{c})$$

Example: Find the volume of a parallelepiped with adjacent sides $\vec{a} = \hat{i} - 2\hat{j} + \hat{k}$,

$$\vec{b} = 3\hat{i} - 3\hat{j} + \hat{k} \text{ and } \vec{c} = -\hat{i} - \hat{j} + 2\hat{k}.$$

Solution: Volume of a parallelepiped with adjacent sides \vec{a} , \vec{b} and \vec{c} is:

$$\vec{a} \cdot \vec{b} \times \vec{c} = \begin{vmatrix} 1 & -2 & 1 \\ 3 & -3 & 1 \\ -1 & -1 & 2 \end{vmatrix}$$

$$= 1(-6 + 1) + 2(6 + 1) + 1(-3 - 3) = -5 + 14 - 6$$

$$= 3 \text{ cubic units}$$

Example: Find the volume of a tetrahedron with vertices A(0, 0, 0), B(1, 3, -1), C(2, 2, 1) and D(1, 6, 5).

Solution:

Let the sides of tetrahedron ABCD are :

$$\vec{a} = \overrightarrow{AB} = (1 - 0)\hat{i} + (3 - 0)\hat{j} + (-1 - 0)\hat{k} = \hat{i} + 3\hat{j} - \hat{k}$$

$$\vec{b} = \overrightarrow{AC} = (2 - 0)\hat{i} + (2 - 0)\hat{j} + (1 - 0)\hat{k} = 2\hat{i} + 2\hat{j} + \hat{k}$$

$$\vec{c} = \overrightarrow{AD} = (1 - 0)\hat{i} + (6 - 0)\hat{j} + (5 - 0)\hat{k} = \hat{i} + 6\hat{j} + 5\hat{k}$$

$$\therefore \text{Volume of tetrahedron} = \frac{1}{6} (\vec{a} \cdot \vec{b} \times \vec{c})$$

$$= \frac{1}{6} \begin{vmatrix} 1 & 3 & -1 \\ 2 & 2 & 1 \\ 1 & 6 & 5 \end{vmatrix}$$

$$= \frac{1}{6} [1(10 - 6) - 3(10 - 1) - 1(12 - 2)]$$

$$= \frac{1}{6} (4 - 27 - 10) = \frac{-33}{6} = \frac{-11}{2}$$

Since volume is a non-negative quantity, so

$$\text{Volume of tetrahedron} = \frac{11}{2} \text{ cubic units}$$

3.7.6 Coplanar Vectors and Condition for the Coplanarity of Three Vectors

Coplanar Vectors

Two or more vectors lying in the same plane are known as coplanar vectors.

Condition for the Coplanarity of Three Vectors

Consider three coplanar vectors \vec{a} , \vec{b} and \vec{c} .

$\vec{a} \times \vec{b}$ is the vector perpendicular to both \vec{a} and \vec{b} .

Since \vec{a} , \vec{b} and \vec{c} are coplanar then $\vec{a} \times \vec{b}$ is also perpendicular to vector \vec{c} , then

$$(\vec{a} \times \vec{b}) \cdot \vec{c} = 0$$

$\therefore \vec{a} \cdot \vec{b} \times \vec{c} = 0$ is the condition for the three vectors to be coplanar.

Example: Find the value of λ so that vectors

$$\vec{a} = \hat{i} - \hat{j} + \hat{k}, \vec{b} = 2\hat{i} + \hat{j} + \hat{k} \text{ and } \vec{c} = -\hat{i} + \lambda\hat{j} + 2\hat{k} \text{ are coplanar.}$$

Solution:

\vec{a} , \vec{b} and \vec{c} will be coplanar if

$$\vec{a} \cdot \vec{b} \times \vec{c} = 0$$

$$\Rightarrow \begin{vmatrix} 1 & -1 & 1 \\ 2 & 1 & 1 \\ -1 & \lambda & 8 \end{vmatrix} = 0$$

$$\Rightarrow 1(8 - \lambda) + 1(16 + 1) + 1(2\lambda + 1) = 0$$

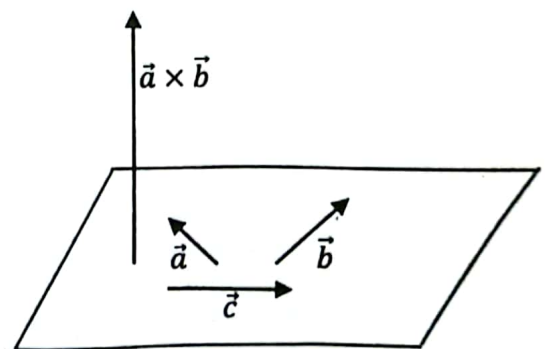

$$\Rightarrow 8 - \lambda + 17 + 2\lambda + 1 = 0$$

$$\Rightarrow \lambda + 26 = 0$$

$$\Rightarrow \lambda = -26$$

Exercise 3.4

- For the given vectors \vec{a} , \vec{b} and \vec{c} ; prove that $\vec{a} \cdot \vec{b} \times \vec{c} = \vec{b} \cdot \vec{c} \times \vec{a} = \vec{c} \cdot \vec{a} \times \vec{b}$
 - $\vec{a} = 3\hat{i} - \hat{j} + 2\hat{k}$; $\vec{b} = 2\hat{i} + 3\hat{j} - \hat{k}$; $\vec{c} = -\hat{i} + 2\hat{j} - 3\hat{k}$
 - $\vec{a} = -2\hat{i} + 7\hat{j} + \hat{k}$; $\vec{b} = 4\hat{i} + 2\hat{j} + \hat{k}$; $\vec{c} = 2\hat{j} + \hat{k}$
- For the given vectors \vec{a} , \vec{b} and \vec{c} ; prove that $\vec{a} \cdot \vec{b} \times \vec{c} = -\vec{b} \cdot \vec{a} \times \vec{c} = -\vec{a} \cdot \vec{c} \times \vec{b}$
 - $\vec{a} = \hat{i} + \hat{j}$; $\vec{b} = \hat{j} + \hat{k}$; $\vec{c} = \hat{i} + \hat{k}$
 - $\vec{a} = 7\hat{i} - 2\hat{j} + \hat{k}$; $\vec{b} = \hat{i} + \hat{j}$; $\vec{c} = \hat{j} - \hat{k}$
- Show that the vectors $\vec{a} = -4\hat{i} - 6\hat{j} - 2\hat{k}$, $\vec{b} = -\hat{i} + 4\hat{j} + 3\hat{k}$ and $\vec{c} = -\hat{i} + 2\hat{j} - 3\hat{k}$ are coplanar.
 - Find the value of λ so that the vectors $\vec{a} = \hat{i} - 2\hat{j} + 3\hat{k}$; $\vec{b} = -2\hat{i} + 3\hat{j} - 4\hat{k}$ and $\vec{c} = -\hat{i} + \lambda\hat{j} + 2\hat{k}$ are coplanar.
- Find the value of λ if the points A(-1, 4, -3); B(3, λ , -5); C(-3, 8, -5) and D(-3, 2, 1) are coplanar.
 - If the vectors $\vec{a} = \alpha\hat{i} + \hat{j} + \hat{k}$; $\vec{b} = \hat{i} + \beta\hat{j} + \hat{k}$ and $\vec{c} = \hat{i} + \hat{j} + \gamma\hat{k}$ are coplanar, then prove that $\frac{1}{1-\alpha} + \frac{1}{1-\beta} + \frac{1}{1-\gamma} = 1$ where $\alpha, \beta, \gamma \neq 1$
- If \vec{a} , \vec{b} and \vec{c} are coplanar then show that $\vec{a} + \vec{b}$, $\vec{b} + \vec{c}$ and $\vec{c} + \vec{a}$ are also coplanar.
 - If \vec{a} , \vec{b} and \vec{c} are non-zero vectors such that \vec{c} is a unit vector perpendicular to both \vec{a} and \vec{b} and the angle between \vec{a} and \vec{b} is $\frac{\pi}{6}$; then prove that $[\vec{a} \ \vec{b} \ \vec{c}]^2 = \frac{1}{4}|\vec{a}|^2|\vec{b}|^2$
- Find the volume of the parallelepiped with given three coterminal edges:
 - $\vec{a} = 2\hat{i} + 3\hat{j} - 4\hat{k}$; $\vec{b} = \hat{i} + 2\hat{j} - 3\hat{k}$; $\vec{c} = 3\hat{i} + \hat{j} + \hat{k}$
 - $\vec{a} = -3\hat{i} + 6\hat{j} + \hat{k}$; $\vec{b} = \hat{i} + 2\hat{j} + 3\hat{k}$; $\vec{c} = -\hat{i} + 2\hat{j} + 6\hat{k}$
- Find the volume of the tetrahedron with given vertices:
 - A(2, 1, 0); B(-1, 2, 6); C(2, 0, 3); D(1, -1, 0)
 - A(0, 1, 0); B(2, 0, 1); C(3, 1, 2); D(5, 6, -1)

3.8 Application of Vectors in Real World

Vectors can be used by air-traffic controllers when tracking planes, by meteorologists when describing wind conditions, and by computer programmers when they are designing virtual worlds. In this section, we will present some applications of vectors that are commonly used in the study of physics: work, torque, and magnetic force.

Projectile Motion

A projectile (stone) thrown with an initial speed u at angle ϕ with the horizontal, has a vertical component of $(u \sin \phi - g t)$ and the horizontal component of $u \cos \phi$ under components of vector.

Sharpening wooden pencil with a blade

We cut the pencil at an angle. The component of force in the direction perpendicular to the pencil cuts the pencil. The component of force in the direction parallel to the pencil removes the thin wooden part.

Earth's magnetic field

Earth's magnetic field has two components B and H which are perpendicular to Earth's surface and parallel to the surface.

Pendulum

The tension in the string has two components to balance the weight and to give the centripetal force.

Digital graphics: Vector art can be defined as digital graphics using mathematical formulas to construct shapes and lines. Vector images maintain their quality irrespective of size. This adaptability makes vector file formats flexible, resilient, and always looking sharp. Vector artwork is digital art produced with vector design software like Linearity Curve (formerly Vectinator), Adobe Illustrator, and Sketch. These vector graphics editors generate simple shapes between points instead of pixels.

Programming: A vector, in programming, is a type of array that is one dimensional. Vectors are a logical element in programming languages that are used for storing a sequence of data elements of the same basic type. Members of a vector are called components.

GPS Unit: When you use your GPS unit to get from point A to point B. The GPS unit will give you a distance (magnitude) and a direction. A vector is, therefore, a directed quantity: a number with a direction.

Example: An air-plane is flying with an airspeed of 475 km/h on heading of 70° . If an 80 km/h wind is blowing from a true heading of 120° . Determine the velocity and direction of plane relative to the ground.

Solution:

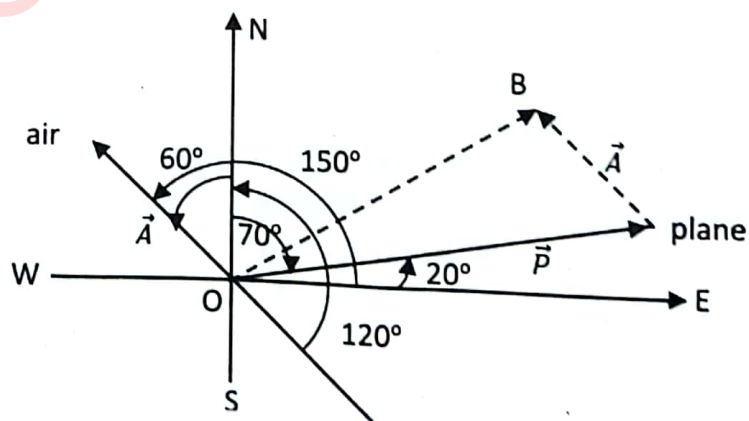

$$\vec{P} = 475 \cos 20^\circ \hat{i} + 475 \sin 20^\circ \hat{j}$$

$$\vec{A} = 80 \cos 150^\circ \hat{i} + 80 \sin 150^\circ \hat{j}$$

$$\vec{P} = 446.35\hat{i} + 162.46\hat{j}$$

$$\vec{A} = -69.28\hat{i} + 40\hat{j}$$

$$\vec{OB} = \vec{P} + \vec{A} = 377.07\hat{i} + 202.46\hat{j}$$

$$\theta = \tan^{-1} \left(\frac{y}{x} \right) = \tan^{-1}(0.536) = 28.23^\circ$$

$$|\vec{OB}| = \sqrt{377.07^2 + 202.46^2} = 428 \text{ km/h}$$

I have Learnt

- Recognizing rectangular coordinate system in space.
- Recognizing: unit vectors \hat{i} , \hat{j} and \hat{k} components of a vector.
- Finding the magnitude of a vector.
- Demonstrating and proving properties of Vector Addition
- Explaining dot or scalar product of two vectors and giving its geometrical interpretation. Expressing dot product in terms of components
- Finding the condition for orthogonality of two vectors and angle between them.
- Finding the projection of a vector along another vector and work done by a force.
- Explaining the cross or vector product of two vectors and giving its geometrical interpretation. Applying cross product to find an angle between two vectors.
- Describing scalar triple product of vectors and expressing it in terms of components.
- Understanding that dot and cross product are interchangeable in scalar triple product
- Recognizing coplanar vectors and finding the condition for planarity of three vectors.

Review Exercise

- Choose the correct option.
 - The vector in the direction of $\hat{i} + 2\hat{j} - 2\hat{k}$ and having magnitude 12 is:

| | |
|--|--|
| a. $\frac{1}{12}(\hat{i} + 2\hat{j} - 2\hat{k})$ | b. $12(\hat{i} + 2\hat{j} - 2\hat{k})$ |
| c. $\frac{1}{4}(\hat{i} + 2\hat{j} - 2\hat{k})$ | d. $4(\hat{i} + 2\hat{j} - 2\hat{k})$ |
 - The position vectors of three vertices of triangle are $2\hat{i} + \hat{j} - \hat{k}$, $3\hat{i} - 2\hat{j} + 4\hat{k}$ and $\hat{i} + 4\hat{j} - 3\hat{k}$. The triangle is:

| | | | |
|--------------|-----------------|------------|----------------|
| a. isosceles | b. right angled | c. scalene | d. equilateral |
|--------------|-----------------|------------|----------------|
 - Given two vectors $\hat{i} - \hat{j}$ and $\hat{i} + 2\hat{j}$, then the unit vector coplanar with two vectors and \perp to first is:

| | |
|--|---|
| a. $\pm \frac{1}{\sqrt{2}}(\hat{i} - \hat{j})$ | b. $\pm \frac{1}{\sqrt{5}}(2\hat{i} + \hat{j})$ |
| c. $\pm \frac{1}{\sqrt{2}}(\hat{i} + \hat{j})$ | d. $\pm \frac{1}{\sqrt{5}}(\hat{i} + 2\hat{j})$ |

- iv. If $|\vec{a} + \vec{b}| = |\vec{a} - \vec{b}|$ then:
- a. $|\vec{a}| = |\vec{b}|$ b. $\vec{a} \perp \vec{b}$ c. $\vec{a} \parallel \vec{b}$ d. $\vec{a} = \vec{b} = 0$
- v. If \hat{a}, \hat{b} and \hat{c} are mutually perpendicular unit vectors; the value of $|\hat{a} + \hat{b} + \hat{c}|$ is:
- a. 1 b. $\sqrt{2}$ c. $\sqrt{3}$ d. 2
- vi. If $\vec{a} + \vec{b} + \vec{c} = 0$ and $|\vec{a}| = 3, |\vec{b}| = 5, |\vec{c}| = 7$ then angle between \vec{a} and \vec{b} is:
- a. $\frac{\pi}{6}$ b. $\frac{2\pi}{3}$ c. $\frac{5\pi}{3}$ d. $\frac{\pi}{3}$
- vii. If $\vec{a} = 2\hat{i} + 3\hat{j} - \hat{k}; \vec{b} = -\hat{i} + 2\hat{j} - 4\hat{k}$ and $\vec{c} = \hat{i} + \hat{j} + \hat{k}$ then the value of $(\vec{a} \times \vec{b}) \cdot (\vec{a} \times \vec{c})$ is:
- a. 74 b. -74 c. 52 d. -52
- viii. If $|\vec{a} \times \vec{b}| = 4$ and $|\vec{a} \cdot \vec{b}| = 2$; then $|\vec{a}|^2 |\vec{b}|^2$ is:
- a. 6 b. 20 c. 2 d. 8
- ix. If θ is the angle between the two vectors \vec{a} and \vec{b} and $|\vec{a} \times \vec{b}| = |\vec{a} \cdot \vec{b}|$ then value of θ is:
- a. 0 b. $\frac{\pi}{6}$ c. $\frac{\pi}{4}$ d. $\frac{\pi}{2}$
- x. The value of $[\vec{a} - \vec{b} \quad \vec{b} - \vec{c} \quad \vec{c} - \vec{a}]$ where $|\vec{a}| = 1, |\vec{b}| = 5, |\vec{c}| = 3$ is:
- a. 0 b. 1 c. 6 d. 15
2. Find the value of λ so that the vectors $\vec{a} = 3\hat{i} - 2\hat{j} + 6\hat{k}$ and $\vec{b} = \hat{i} - \lambda\hat{j} + 3\lambda\hat{k}$ are:
- i. parallel ii. perpendicular
3. If $\vec{a} = -3\hat{i} + 2\hat{j} + 4\hat{k}$ and $\vec{b} = \hat{i} - 2\hat{j} + 4\hat{k}$ then find the component of $\vec{a} + \vec{b}$ along $\vec{a} - \vec{b}$.
4. Find $|\vec{u}|$ if \hat{v} is unit vector and $(\vec{u} - \hat{v}) \cdot (\vec{u} + \hat{v}) = 18$.
5. The scalar product of $\hat{i} + \hat{j} - \hat{k}$ with the unit vector along the sum of the vectors $2\hat{i} - 3\hat{j} + \hat{k}$ and $\lambda\hat{i} - 2\hat{j} + 3\hat{k}$ is 1. Find the value of λ .
6. For any vector \vec{a} ; prove that $|\vec{a} \times \hat{i}|^2 + |\vec{a} \times \hat{j}|^2 + |\vec{a} \times \hat{k}|^2 = 2|\vec{a}|^2$.
7. With usual notations for a triangle ABC ; prove that $\frac{a}{\sin \alpha} = \frac{b}{\sin \beta} = \frac{c}{\sin \gamma}$ by vector method.
8. Suppose an airplane has a velocity relative to the air with a speed of 200 km/h and a direction of 60° . Suppose the wind is blowing from the west at 40 km/h. Calculate the ground speed and the true course for the plane.
9. A pilot wants to have a true course of 100° with a ground speed of 250 km/h. If the wind has a velocity vector $(r, \theta) = (20, 30^\circ)$, what should be the speed and direction of airplane with respect to air.

UNIT
04

SEQUENCES AND SERIES

After studying this unit, students will be able to:

- Define an arithmetic sequence and find its general term.
- Know arithmetic mean between two numbers. Also insert n arithmetic means between them.
- Define an arithmetic series and establish the formula to find the sum to n terms of the series.
- Show that sum of n arithmetic means between two numbers is equal to n times their AM.
- Solve real life problems involving arithmetic sequence, arithmetic mean and arithmetic series.
- Define a geometric sequence and find its general term.
- Know geometric mean between two numbers. Also insert n geometric means between them.
- Define a geometric series and find the sum of n terms of a geometric series.
- Find the sum of an infinite geometric series.
- Convert the recurring decimal into an equivalent common fraction.
- Solve real life problems involving geometric sequence, geometric mean and series.
- Recognize a harmonic sequence and find n th term of harmonic sequence.
- Define a harmonic mean and insert n harmonic means between two numbers.
- Recognize sigma (Σ) notation.
- Find sum of
 - the first n natural numbers (Σn),
 - the squares of the first n natural numbers (Σn^2),
 - the cubes of the first n natural numbers (Σn^3).
- Define arithmetico-geometric series.
- Find sum to n terms of the arithmetico-geometric series.
- Define method of differences. Use this method to find the sum of n terms of the series whose differences of the consecutive terms are either in arithmetic or in geometric sequence.
- Use partial fractions to find the sum to n terms and to infinity the series of the type:

$$\frac{1}{a(a+d)} + \frac{1}{(a+d)(a+2d)} + \dots$$

A sequence is simply an ordered list. For example, a superball dropped from the top of the tower (556 ft high) always rebounds three fourths of the distance fallen. How far (up and down) will the ball have traveled when it hits the ground for the 6th time, a sequence is being formed? When the members of a sequence are numbers, we can find their sum. Such a sum is called series.



4.1 Sequence

We encounter sequences at the very beginning of our mathematical experiences. The list of even numbers;

$$2, 4, 6, 8, 10\dots$$

and the list of odd numbers;

$$1, 3, 5, 7, 9\dots$$

are examples. We can 'predict' what the 20th term of each sequence will be just by using common sense.

Sequences can be either finite or infinite. For example,

$$2, 4, 6, 8, 10$$

is a finite sequence with five terms whereas,

$$2, 4, 6, 8, 10\dots$$

continues without bound and is an infinite sequence. We usually use '...', three dots to denote that the sequence continues without bound.

For a given infinite sequence, we can ask the questions.

- Can we find a formula for the general term of the sequence?
- Does the sequence have a limit, that is, do the number in the sequence get as close as we like to some number?

For example, we can see infinitively that the terms in an infinite sequence

$$1, \frac{1}{2}, \frac{1}{3}, \frac{1}{4}, \frac{1}{5}, \dots$$

whose general term is $\frac{1}{n}$, are approaching zero as n becomes very large.

The list of positive odd numbers:

$$1, 3, 5, 7, 9, \dots$$

is an example of a typical infinite sequence. We use the symbol a_n to denote the n th term of a given sequence. Thus, in the above sequence; $a_1 = 1$, $a_2 = 3$, $a_3 = 5$ and so on, the first term is $a_1 = 1$, but there is no last term.

The list of positive odd numbers less than 100 is:

$$1, 3, 5, 7, 9, \dots, 99$$

This is an example of finite sequence. The last term is 99. This sequence contains 50 terms.

There are several ways to display a sequence.

- Write out the first few terms.
- Give a formula for the general terms.
- Give a recurrence relation.

A much better way to describe a sequence is to give a formula for the n th term a_n . This is also called a formula for the general term. For example, $a_n = 2n - 1$ is the general term for the sequence of odd numbers.

Consider the sequence 2, 4, 8, 16,...

Here, first term: $a_1 = 2^1 = 2$

second term: $a_2 = 2^2 = 4$

third term: $a_3 = 2^3 = 8$

The general term is $a_n = 2^n$

This sequence can also be written as:

$$2, 4, 8, \dots, 2^n, \dots$$

Example: Find the first four terms and the 57th term of the sequence whose general term is

given by $a_n = \frac{(-1)^n}{n+1}$.

Solution: $a_1 = \frac{(-1)^1}{1+1} = -\frac{1}{2}$, $a_2 = \frac{(-1)^2}{2+1} = \frac{1}{3}$
 $a_3 = \frac{(-1)^3}{3+1} = -\frac{1}{4}$, $a_4 = \frac{(-1)^4}{4+1} = \frac{1}{5}$
 $a_{57} = \frac{(-1)^{57}}{57+1} = -\frac{1}{58}$

Note that the expression $(-1)^n$ causes the signs of the terms to alternate between positive and negative, depending on whether n is even or odd.

Example: For each sequence, predict the general terms.

- (i) 1, 4, 9, 16, 25, ...
- (ii) $\sqrt{1}, \sqrt{2}, \sqrt{3}, \sqrt{4}, \dots$
- (iii) -1, 2, -4, 8, -16, ...
- (iv) 2, 4, 8, 16, ...

Solution: (i) There are squares of consecutive positive integers.

So, the general term is n^2 i.e. $a_n = n^2$.

(ii) There are square roots of consecutive positive integers. So, the general term is \sqrt{n} .

(iii) There are powers of 2 starting from 0 with alternating signs.

So, the general term is $(-1)^n [2^{n-1}]$.

(iv) If we see the pattern of powers of 2, we will see 16 as the next term and gives 2^n for the general term.

Triangular Numbers

A triangular number counts objects arranged in an equilateral triangle. The n th triangular number is the number of dots in the triangular arrangement with n dots on each side and is equal to the sum of the integers from 0 to n . The sequence of triangular numbers, starting at the 1st triangular number, is

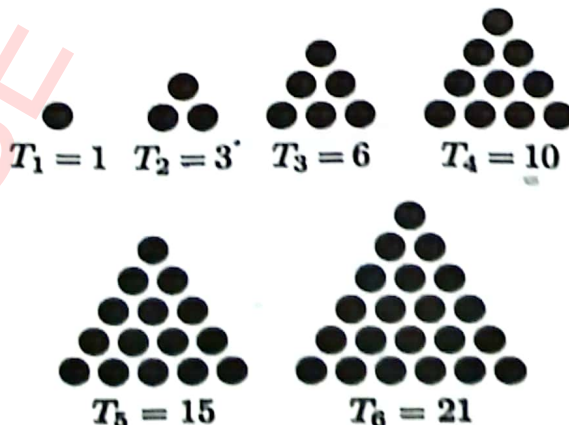

1, 3, 6, 10, 15, 21, 28, 36, 45, 55, 66, 78, 91,...

The formula for n th triangular number is given by $T_n = \frac{n(n+1)}{2}$

For example; $T_{10} = \frac{10(10+1)}{2} = 55$

Pascal's Triangle

One of the most interesting number patterns is Pascal's Triangle (named after Blaise Pascal, a famous French mathematician and Philosopher). To build the triangle, start with "1" at the top, then continue placing numbers below it in a triangular pattern. Each number is the number directly above is added together.

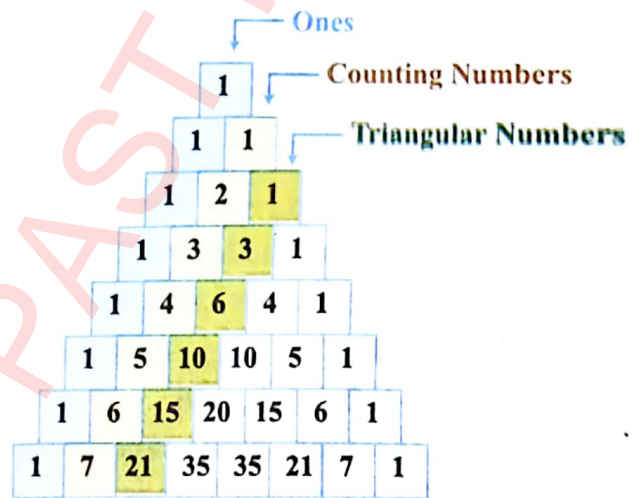

Diagonals

The first diagonal is of count, just "1".

The second diagonal has the "counting numbers" (1, 2, 3, 4,...).

The third diagonal has the "triangular numbers".

Exercise 4.1

In each of the following, the n th term of the sequence is given. In each case find the first 4 terms; the 10th term, a_{10} and the 15th term, a_{15} .

1. $a_n = 3n + 1$
2. $a_n = 3n - 1$
3. $a_n = \frac{n}{n+1}$
4. $a_n = n^2 + 1$
5. $a_n = n^2 - 2n$
6. $a_n = \frac{n^2-1}{n^2+1}$
7. $a_n = \left(\frac{-1}{2}\right)^{n-1}$
8. $a_n = (-1)^2 \cdot n^2$
9. $a_n = (-1)^n (n + 3)$
10. $a_n = (-1)^{n+1} (3n - 5)$

Find the indicated term of the sequence.

11. $a_n = 4n - 3$; a_8
12. $a_n = 5n + 11$; a_9
13. $a_n = (3n + 4)(2n - 5)$; a_7
14. $a_n = (-1)^{n-1} (3.4n - 17.3)$; a_{12}
15. $a_n = 4n^2 (11n + 31)$; a_{22}
16. $a_n = \left(1 + \frac{1}{n}\right)^2$; a_{20}
17. $a_n = \log 10^n$; a_{43}
18. $a_n = \ln e^n$; a_{67}

Predict the general term or nth term, a_n , of the sequence.

19. 1, 3, 5, 7, 9,...

20. 3, 9, 27, 81, 243,...

21. $\sqrt{2}, \sqrt{4}, \sqrt{6}, \sqrt{8}, \sqrt{10}, \dots$

22. 1.2, 2.3, 3.4, 4.5,...

4.2 Arithmetic Sequence

A professional race car driver drives out of a curve. He enters the straight away at 119.9 mph. He increases his speed by 78.3 mph and after 9 seconds his speed is 198.2 mph.

The table below shows how his speed increased each second after entering the straight path.

| | | | | | | | | | | |
|-------------------|-------|-------|-------|-------|-------|-------|-------|-------|-------|-------|
| Number of seconds | 0 | 1 | 2 | 3 | 4 | 5 | 6 | 7 | 8 | 9 |
| Speed in mph | 119.9 | 128.6 | 137.3 | 146.0 | 154.7 | 163.4 | 172.1 | 180.8 | 189.5 | 198.2 |

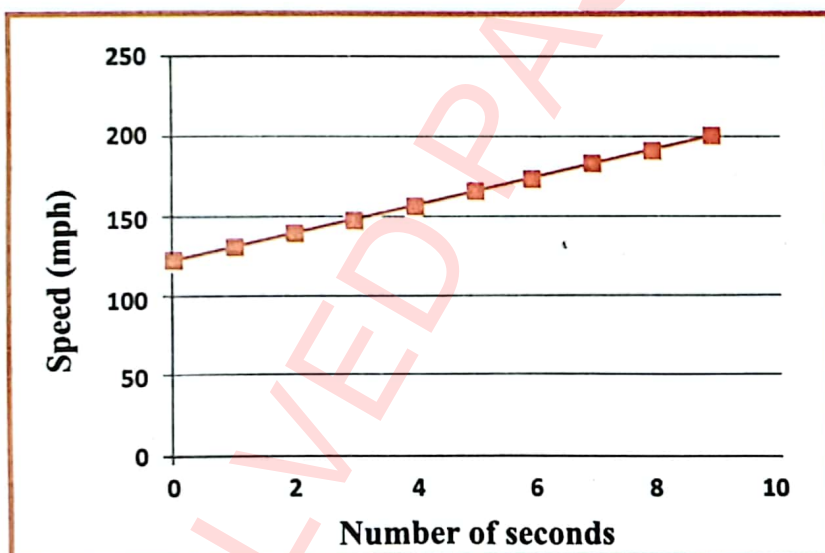

From the table and graph, we observe the number and pattern. This set of numbers is an example of a **sequence**. Each number in a sequence is called a **term**. The first term is symbolized by a_1 , the second term by a_2 and so on to a_n , the nth term. The sequence shown in the table contains ten terms. Therefore, $a_1=119.9$, $a_2=128.6$ and $a_{10} = 198.2$ (each term is obtained by adding 8.7 to the previous term). A sequence of this type is called an **arithmetic sequence** or **arithmetic progression**. The number added to find the next term of an arithmetic sequence is called the **common difference** and is symbolized by the variable d .

Definition

An arithmetic sequence is a sequence in which each term, after the first, is found by adding a constant called the common difference, to the previous term.

To find the next terms in an arithmetic sequence, first find the common difference d by subtracting any term from its succeeding term, then add the common difference to the last term to find successive terms.

Example: Find the next four terms of the arithmetic sequence 33, 39, 45...

Solution: Find the common difference d by subtracting two consecutive terms.

$$d = 39 - 33 = 6 \quad \text{or} \quad d = 45 - 39 = 6.$$

Now add 6 to the last term of the sequence and then continue adding until the next four terms are found.

$$\begin{aligned} a_4 &= 45 + 6 = 51, & a_5 &= 51 + 6 = 57 \\ a_6 &= 57 + 6 = 63, & a_7 &= 63 + 6 = 69 \end{aligned}$$

The next four terms of the sequence are 51, 57, 63, and 69.

In this way terms of an arithmetic sequence are formed. A formula to find any term of an arithmetic sequence can be found if you know the first term and the common difference. This formula is known as a **recursive formula**. Recursive means that each succeeding term is formulated from one or previous terms.

| | | | | | | | | | |
|-------------------|-------------------|-------------------|-------------------|-------------------|---|---|---|---|----------------|
| a_1 | a_2 | a_3 | a_4 | a_5 | . | . | . | . | a_n |
| 33 | 39 | 45 | 51 | 57 | . | . | . | . | a_n |
| $33 + 0(6)$ | $33 + 1(6)$ | $33 + 2(6)$ | $33 + 3(6)$ | $33 + 4(6)$ | . | . | . | . | $33 + (n-1)d$ |
| $a_1 + 0 \cdot d$ | $a_1 + 1 \cdot d$ | $a_1 + 2 \cdot d$ | $a_1 + 3 \cdot d$ | $a_1 + 4 \cdot d$ | . | . | . | . | $a_1 + (n-1)d$ |

4.2.1 Formula for the n th Term of an Arithmetic Sequence

The n th term a_n , of an arithmetic sequence with first term a_1 and common difference d is given by

$$a_n = a_1 + (n - 1)d$$

Note that the coefficient of d in each case is 1 less than subscript.

Example:

Suppose a race car driver increases speed at constant rate. What will his speed be after 15 seconds, if his initial speed is 85 mph and his rate of acceleration is 4.5 mph per second?

Solution:

$$a_1 = 85 \quad \text{and} \quad d = 4.5, \quad a_{16} = ? \quad (\text{After 15 sec means we have to find } a_{16} \text{ term})$$

Find a_{16} using $a_n = a_1 + (n - 1)d$

$$a_{16} = 85 + (16 - 1)(4.5)$$

$$a_{16} = 152.5$$

His speed will be 152.5 mph after 15 seconds.

Example: The third term of an arithmetic sequence is 8, and the sixteenth term is 47. Find a_1 , d and construct the sequence. Also find a_{15} .

Solution: We know that $a_3 = 8$ and $a_{16} = 47$. We need first term a_1 and d (common difference).

$$a_3 = 8 \text{ (Here } n = 3\text{)}$$

So, $a_3 = a_1 + (3 - 1)d \Rightarrow 8 = a_1 + 2d$ (i)

and $a_{16} = 47$ (Here $n = 16$)

$$a_{16} = a_1 + (16 - 1)d \Rightarrow 47 = a_1 + 15d$$
 (ii)

Solving (i) and (ii), we have

$$a_1 = 2, \quad d = 3$$

So, $a_1 = 2, \quad a_2 = a_1 + 1 \cdot d = 2 + 3 = 5, \quad a_3 = a_1 + 2 \cdot d = 2 + 6 = 8,$

$$a_4 = a_1 + 3 \cdot d = 2 + 9 = 11$$

The sequence is 2, 5, 8, 11, ...

Now, $a_{15} = a_1 + (15 - 1)d = a_1 + 14d = 2 + 14(3)$

$$a_{15} = 44$$

4.2.2 Arithmetic Mean

To find arithmetic mean between two numbers a and b , we use formula

$$A.M = \frac{a+b}{2}$$

A number A is said to be arithmetic mean (A.M) between two numbers a and b if a, A, b are in A.P.

If d is the common difference, then

$$d = A - a = b - A$$

$$2A = a + b$$

$$A = \frac{a+b}{2}$$

Example:

Find the four arithmetic means between 19 and 54.

Solution: We can use the n th term formula to find the common difference.

In the sequence 19, _____, _____, _____, _____, 54; we have, $a_1 = 19$ and $a_6 = 54$.

To find d , use $a_6 = a_1 + 5d$

$$54 = 19 + 5d \Rightarrow d = 7$$

Use $a_1 = 19$ and $d = 7$ to find the four arithmetic means

$$a_2 = a_1 + d = 19 + 7 = 26$$

$$a_3 = a_1 + 2d = 19 + 2(7) = 33$$

$$a_4 = a_1 + 3d = 19 + 3(7) = 40$$

$$a_5 = a_1 + 4d = 19 + 4(7) = 47$$

The four arithmetic means are 26, 33, 40 and 47.

Example: Find the A.M between 6 and 18.

Solution: We have $a_1 = 6, b = 18$, then

Challenge

Find three numbers that have a sum of 27, a product of 288 and form an arithmetic sequence.

$$A.M = \frac{a+b}{2} = \frac{6+18}{2} = 12$$

Example: Find the 7 A.Ms between 7 and 20.

Solution: Let $A_1, A_2, A_3, \dots, A_7$ be the required A.Ms between 7 and 20. Then

$7, A_1, A_2, A_3, A_4, A_5, A_6, A_7, 20$ are in A.P.

$$a_1 = 7, \quad n = 9, \quad a_9 = 20$$

$$a_1 + 8d = 20 \Rightarrow 7 + 8d = 20 \Rightarrow d = \frac{11}{8}$$

$$A_1 = a_1 + d = 7 + \frac{11}{8} = \frac{67}{8}$$

$$A_2 = a_1 + 2d = 7 + 2\left(\frac{11}{8}\right) = \frac{31}{4}$$

Similarly, $A_3 = \frac{103}{8}, A_4 = \frac{57}{4}, A_5 = \frac{21}{2}, A_6 = \frac{68}{5}, A_7 = \frac{147}{10}$

Check Point

Show that sum of n A. Ms between a & b is equal to n times A. M between a & b .

Exercise 4.2

- Find the first four terms of each arithmetic sequence.

| | | |
|-------------------------|--|---|
| (i) $a_1 = 4, d = 3$ | (ii) $a_1 = 7, d = 5$ | (iii) $a_1 = 16, d = -2$ |
| (iv) $a_1 = 38, d = -4$ | (v) $a_1 = \frac{3}{4}, d = \frac{1}{4}$ | (vi) $a_1 = \frac{3}{8}, d = \frac{5}{8}$ |
- Find the next three terms of each arithmetic sequence.

| | |
|--|----------------------------|
| (i) 5, 9, 13, ... | (ii) 11, 14, 17, ... |
| (iii) $\frac{1}{2}, \frac{3}{2}, \frac{5}{2}, \dots$ | (iv) -5.4, -1.4, -2.6, ... |
- Find the 11th term of the arithmetic sequence 0.07, 0.12, 0.7, ...
- The third term of an arithmetic sequence is 14 and the ninth term is -1. Find the first four terms of the sequence.
- Find an arithmetic sequence for $a_{17} = -40$ and $a_{28} = -73$, find a_1 and d . Write first five terms of the sequence.
- The fifth term of an arithmetic sequence is 19 and 11th term is 43. Find the first term and 87th term.
- Which term of the sequence -6, -2, 2, ... is 70?
- Which term of the sequence $\frac{5}{2}, \frac{3}{2}, \frac{1}{2}$ is $-\frac{105}{2}$?
- If $\frac{1}{a}, b, \frac{1}{c}$ are in A.P. Show that the common difference is $\frac{a-c}{2ac}$.
- During a free fall, a sky diver falls 16 feet in the first second, 48 feet in the 2nd second and 80 feet in the third second. If he continues to fall at this rate, how many feet will he fall during the 8th second?
- If Rs. 1000 is saved on August 1, Rs. 3000 on August 2, Rs. 5000 on August 3 and so on. How much is saved till August 20?
- A gardener is making a triangular planting, with 35 plants in the first row, 31 in the second row, 27 in the third row and so on. If the pattern is consistent, how many plants will there be in the eighth row?

13. Find A.M. between
 (i) 7 and 17
 (ii) $3 + 3\sqrt{2}$ and $7 - 3\sqrt{2}$
 (iii) $7\sqrt{5}$ and $\sqrt{5}$
 (iv) $2y + 5$ and $5y + 3$
14. Find 'b' if 10 is A.M between b and 20.
 15. Find x and y if 2 and 13 are two arithmetic means between x and y.
 16. Find the two arithmetic means between 5 and 17.
 17. Find three arithmetic means between 2 and -18.

4.3 Arithmetic Series

A sky driver falls freely covering the distance in the following pattern. These free-fall distances form an arithmetic sequence.

$$16, 48, 80, 112, 144, 176, \dots$$

To find out what the total distance covered by the sky diver is, we would add the terms in the sequence.

$$16 + 48 + 80 + 112 + 144 + 176$$

The indicated sum of the terms of a sequence is called a **series**. Above series is called an **arithmetic series**.

Following are the examples of arithmetic sequences and their corresponding arithmetic series.

Arithmetic Sequence

$$2, 4, 6, 8, 10$$

$$-8, -2, 4$$

$$\frac{4}{5}, \frac{8}{5}, \frac{12}{5}, \frac{16}{5}$$

$$a_1, a_2, a_3, a_4, \dots, a_n$$

Arithmetic Series

$$2 + 4 + 6 + 8 + 10$$

$$-8 + (-2) + 4$$

$$\frac{4}{5} + \frac{8}{5} + \frac{12}{5} + \frac{16}{5}$$

$$a_1 + a_2 + a_3 + a_4 + \dots + a_n$$

The symbol S_n is used to represent the sum of the first n-terms of a series. For example, S_4 means the sum of the first four terms of a series. For example, the sum of series $3 + 6 + 9 + 12$ is 30.

If a series has a large number of terms, it is not convenient to list all the terms and then find their sum. To develop a general formula for the sum of any arithmetic series, let's consider the series of sky diving distances.

$$16 + 48 + 80 + 112 + 144 + 176$$

We write S_6 in two different orders and find the sum.

$$S_6 = 16 + 48 + 80 + 112 + 144 + 176$$

$$+ S_6 = 176 + 144 + 112 + 80 + 48 + 16$$

$$2S_6 = 192 + 192 + 192 + 192 + 192 + 192 \quad \dots \quad 6 \text{ times } 192 \text{ (6 sums of 192)}$$

$$= 6 [192] \Rightarrow S_6 = \frac{6}{2} [192] \quad (\text{Divide each side by 2})$$

Here, 6 represents n, 192 represents the sum of the first and last terms ($16 + 176$) i.e. $a_1 + a_n$. We can replace the equation with the formula:

$$S_n = \frac{n}{2} [a_1 + a_n] \tag{i}$$

We have learnt that in an arithmetic sequence, $a_n = a_1 + (n - 1) d$. Using this formula(i), we get another version for the sum of an arithmetic sequence.

$$S_n = \frac{n}{2} [a_1 + a_n] ; \quad \text{replace } a_n \text{ with } a_1 + (n - 1) d$$

$$S_n = \frac{n}{2} [a_1 + (a_1 + (n - 1) d)]$$

$$S_n = \frac{n}{2} [2a_1 + (n - 1) d]$$

The sum S_n of the first n-terms of an arithmetic series is given by:
$$S_n = \frac{n}{2} [a_1 + a_n] = S_n = \frac{n}{2} [2a_1 + (n - 1) d]$$

Example: Find the sum of the first 100 positive integers.

Solution:

1st Method: In this series, $a_1 = 1$ and $a_n = a_{100} = 100$

$$S_n = \frac{n}{2} [a_1 + a_n]$$

$$S_{100} = \frac{100}{2} [1 + 100] = 5050$$

2nd Method Sum is $1 + 2 + 3 + \dots + 100$ term

$$a_1 = 1, d = 1, n = 100$$

$$S_n = \frac{n}{2} [2a_1 + (n - 1) d]$$

$$S_{100} = \frac{100}{2} [2(1) + (100 - 1)(1)]$$

$$S_{100} = 50 [101] = 5050$$

Example:

Find the sum of the first 50 terms of an arithmetic series where $a_1 = 5$ and $d = 25$.

Solution: Given

$$a_1 = 5, d = 25, n = 50$$

$$S_n = \frac{n}{2} [2a_1 + (n - 1) d]$$

$$S_{50} = \frac{50}{2} [2(5) + (50 - 1)(25)] \tag{substituting values}$$

$$S_{50} = 25 [10 + (49)(25)] = 30875$$

Example: Theaters are often built with more seats per row as the rows move towards the back. Suppose the main floor of a theater has 28 seats in the first row, 32 in the second, 36 in the third and so on for 50 rows. How many seats are on the main floor?

Solution: From the given information, 1st row = 28, 2nd row = 32, 3rd row = 36. The series is:

$$28 + 32 + 36 + \dots \quad (50 \text{ rows})$$

$$a_1 = 28, d = 4, n = 50$$

$$S_n = \frac{n}{2} [2a_1 + (n - 1)d]$$

$$S_{50} = \frac{50}{2} [2(28) + (50 - 1)(4)] \quad (\text{substituting values})$$

$$S_{50} = 25 [56 + 196] = 6300$$

Example:

Find the first three terms of an arithmetic series where $a_1 = 17$, $a_n = 101$ and $S_n = 472$.

Solution: First, find 'n'.

$$S_n = \frac{n}{2} [a_1 + a_n];$$

$$472 = \frac{n}{2} [17 + 101] \Rightarrow 944 = 18n \Rightarrow n = 8$$

Next, find 'd'.

$$a_n = a_1 + (n - 1)d$$

$$101 = 17 + (8 - 1)d$$

$$84 = 7d \Rightarrow d = 12$$

Now we have:

$$a_2 = a_1 + d = 17 + 12 = 29$$

$$a_3 = a_1 + 2d = 17 + 2(12) = 41$$

Thus, the first three terms are 17, 29 and 41.

Exercise 4.3

Find the sum of each series (1 - 7).

1. $4 + 7 + 10 + 13 + 16 + 19 + 22 + 25$
2. $a_1 = 2, a_n = 200, n = 100$
3. $a_1 = 5, a_n = 100, n = 200$
4. $a_1 = 4, n = 15, d = 3$
5. $a_1 = 50, n = 20, d = -4$
6. $-3 + (-7) + (-11) + \dots + a_{10}$
7. $9 + 11 + 13 + 15 + \dots$ for $n = 12$
8. Find the sum of the even numbers from 2 to 100.
9. Find the sum of the odd numbers from 1 to 99.
10. Find the sum of all multiples of 4 that are between 14 and 523.

Find S_n for each arithmetic series.

11. $a_1 = 3, a_n = -38, n = 8$
12. $a_1 = 85, n = 21, a_n = 25$
13. $a_1 = 34, n = 9, a_n = 2$
14. $a_1 = 5, d = \frac{1}{2}, n = 13$
15. $a_1 = 91, d = -4, a_n = 15$
16. $d = -4, n = 9, a_n = 27$

Find sum of the arithmetic series.

17. $6 + 12 + 18 + \dots + 96$
18. $34 + 30 + 26 + \dots + 2$

19. $10 + 4 + (-2) + \dots + (-50)$

Find the first three terms of each arithmetic series.

20. $a_1 = 7, a_n = 139, S_n = 876$

21. $n = 14, a_n = 53, S_n = 378$

22. $a_1 = 6, a_n = 306, S_n = 1716$

23. A formation of a marching band has 14 marches in the front row, 16 in the second row, 18 in the third row and so on, for 25 rows. How many marchers are in the last row? How many marchers are there altogether?
24. How many poles will be in a pile of telephone poles if there are 50 in the first layer, 49 in the second and so on, until there are 6 in the last layer?
25. A family saves money in an arithmetic sequence: Rs. 6000 in the first year, Rs. 70,000 in second year and so on, for 20 years. How much do they save in all?
26. Mr. Saleem saves Rs. 500 on October 1, Rs. 550 on October 2, and Rs. 600 on October 3 and so on. How much is saved during October? (October has 31 days)

4.4 Geometric Sequence

Iodine is used medically as a tracer isotope in monitoring the activity of the thyroid gland. A patient is given a compound containing the radioactive iodine. The amount of iodine retained by this gland is a measure of its ability to function.

Iodine has a half-life of about 8 days. That means approximately every 8 days, half the mass of iodine decays into another element. Then in the next 8 days, half of the remaining iodine decays, and so on.

Suppose a container hold a mass of 64 milligrams of iodine. To find the remaining mass of iodine after each half-life, 64, 32, 16, 8, 4, 2, 1, and 0.5, are what type of patterns do you suggest?

The pattern of masses forms a sequence of numbers known as a **geometric sequence** or **geometric progression**. The terms in this example are 64, 32, 16, 8, 4, 2, 1, and 0.5.

Definition

A geometric sequence is one in which each term after the first is found by multiplying the previous term by a constant (not zero) called the common ratio.

In any geometric sequence, the common ratio r is found by dividing any term by the previous term.

Example: Find the next two terms of the geometric sequence 4, 12, and 36.

Solution: To find the common ratio, find the quotient of any two consecutive terms.

$$\frac{12}{4} = \frac{36}{12} = 3; \text{ the common ratio is } 3.$$

The fourth term = $36(3) = 108$

The fifth term = $108(3) = 324$

∴ The next two terms of the geometric sequence are 108 and 324.

4.4.1 Formula for the nth Term of a Geometric Sequence

Successive terms of a geometric sequence are usually expressed in the product of r and the previous term. Thus, a geometric sequence is also a recursive sequence. Each succeeding term in a GP contains a factor of r , each term can be expressed as a product of r .

We derive the formula for GP using previous example. Observe the following table:

| | | | | | | | | | | |
|-------|-------------|---------------|----------------|---|---|---|---|---|---|--------------|
| a_1 | a_2 | a_3 | a_4 | . | . | . | . | . | . | a_n |
| 4 | $4(3) = 12$ | $4(3^2) = 36$ | $4(3^3) = 108$ | . | . | . | . | . | . | $4(r^{n-1})$ |
| a | ar | ar^2 | ar^3 | . | . | . | . | . | . | ar^{n-1} |

The n th term a_n of a geometric sequence with first term a_1 and the common ratio r is given by formula:

$$a_n = a_1 r^{n-1}$$

Example: Write the first five terms of a geometric sequence in which $a_1 = 5$ and $r = 2$.

Solution: Given $a_1 = 5$. Write next term using formula; $a_n = a_1 r^{n-1}$

$$a_2 = a_1 r^{2-1} = a_1 r = (5)(2) = 10 \quad (\text{Substituting values } a_1 = 5, r = 2 \text{ and } n = 2, 3, 4, 5)$$

$$a_3 = a_1 r^{3-1} = a_1 r^2 = (5)(2)^2 = 20$$

$$a_4 = a_1 r^{4-1} = a_1 r^3 = (5)(2)^3 = 40$$

$$a_5 = a_1 r^{5-1} = a_1 r^4 = (5)(2)^4 = 80$$

∴ The first five terms of a sequence are 5, 10, 20, 40, and 80.

Example: Find the seventh term, a_7 , of a geometric sequence in which $a_3 = 96$ and $r = 4$.

Solution: The general form of the third term of a sequence is $a_1 r^2 (a_1 r^{3-1})$.

We have $a_3 = 96, r = 4, a_7 = ?$

$$a_3 = a_1 r^2$$

$$96 = a_1 (4)^2; \quad (\text{we need } a_1 \text{ to find } a_7)$$

$$96 = a_1 (16) \Rightarrow a_1 = 6$$

Thus, $a_7 = a_1 r^6 = (6)(4)^6 = 24,576$.

Example:

Mr. Khalid saves Rs. 1000 on the first day. Then each day thereafter, saves double the amount he saved the day before. Find the amount he should save the 20th day of the month.

Solution:

In this sequence, $a_1 = 1000$. Since the amount of money is twice that of day before, so $r = 2$.

$$a_n = a_1 r^{n-1} ; \quad a_{20} = ?$$

$$a_{20} = a_1 r^{20-1} = a_1 r^{19} = (1000)(2)^{19}$$

$$a_{20} = 524288000$$

On the 20th day, Khalid should save Rs. 524,288,000.

4.5 Geometric Mean

If a, G, b is in a geometric sequence, then G is called the geometric mean of a and b .

From geometric sequence a, G, b , we have :

Common ratio: $r = \frac{a}{G}$ (i), $r = \frac{G}{b}$ (ii)

Form (i) and (ii)

$$\frac{a}{G} = \frac{G}{b} \Rightarrow G^2 = ab$$

$$G = \pm\sqrt{ab}$$

Thus the geometric means of two numbers is the square root of their product.

Key Facts



- The positive square root is chosen, if both the numbers are positive.
- The negative square root is chosen, if both the numbers are negative.
- The mean is imaginary, if two numbers have opposite signs.

Example: Find the geometric mean of each of the following pairs of numbers.

(i) 9 and 4 (ii) $-\frac{3}{2}$ and $-\frac{27}{8}$

Solution: (i) Here $a = 9$ and $b = 4$. So,

$$G = \sqrt{ab} \quad (\text{both are positive})$$

$$G = \sqrt{9 \times 4} = 6$$

(ii) Given $a = -\frac{3}{2}$, $b = -\frac{27}{8}$

$$G = \sqrt{ab} \quad (\text{both are negative})$$

$$= \sqrt{-\frac{3}{2} \times -\frac{27}{8}} = -\sqrt{\frac{81}{16}}$$

$$= -\frac{9}{4}$$

Example: Find two geometric means between 81 and 3.

Solution: The sequence is 81, _____, _____, 3.

Use the general formula for the n th term to find the value of r .

Since $a_1 = 81$, $a_4 = 3$, $n = 4$.

So, $a_4 = a_1 r^{n-1}$ becomes $a_4 = a_1 r^3$ or $3 = 81 (r)^3$

$$r^3 = \frac{1}{27} \Rightarrow (r)^3 = \left(\frac{1}{3}\right)^3 \quad (\text{taking cube})$$

$$\Rightarrow r = \frac{1}{3}$$

$$a_2 = a_1 r = 81 \left(\frac{1}{3}\right) = 27$$

$$a_3 = a_1 r^2 = 81 \left(\frac{1}{3}\right)^2 = 9$$

The missing geometric means are 27 and 9.

Example: A vacuum pump removes $\frac{1}{5}$ of the air from a sealed container on each stroke of its piston. What percent of the air remains after five stroke of the piston?

Solution:

Let 1 represent the original amount of air. After the first stroke, $1 - \frac{1}{5}$ or $\frac{4}{5}$ of the air remains.

The second stroke removes $\frac{1}{5}$ of the remaining air.

Thus the amount that remain after two strokes is $\frac{4}{5} \left(1 - \frac{1}{5}\right) = \frac{4}{5}, \frac{4}{5}$ or $\frac{16}{25}$

This pattern can be expressed as a geometric sequence.

| | | | | | | |
|--------------------------|-------|---------------|-----------------|-------|-------|-------|
| Number of strokes | 0 | 1 | 2 | 3 | 4 | 5 |
| Sequence | 1 | $\frac{4}{5}$ | $\frac{16}{25}$ | | | |
| Terms | a_1 | a_2 | a_3 | a_4 | a_5 | a_6 |

Now we use the formula $a_n = a_1 r^{n-1}$ to find a_6 , the amount of air left after five strokes

$$a_n = a_1 r^{n-1} \quad (\text{substituting the values; } a_1 = 1 \text{ and } r = \frac{4}{5})$$

$$a_6 = 1 \cdot \left(\frac{4}{5}\right)^5 \text{ or } \frac{4^5}{5^5}$$

$$a_6 = \frac{1024}{3125} \text{ or } 0.32768$$

Exercise 4.4

Determine whether each sequence is geometric. If so, find the common ratio.

1. 5, 20, 100, 500, ...
2. 2, 4, 6, 8, ...
3. $\frac{3}{2}, \frac{9}{4}, \frac{27}{8}, \frac{81}{16}, \dots$
4. 7, 14, 21, 28, ...

Find the first four terms of the geometric sequence.

5. $a_1 = 3, r = -2$
6. $a_1 = 27, r = -\frac{1}{3}$
7. $a_1 = 12, r = \frac{1}{2}$

Find the next two terms of each geometric sequence.

8. 90, 30, 10, ...
9. 2, 6, 18, ...
10. 20, 30, 45, ...
11. 729, 243, 81, ...
12. $\frac{1}{27}, \frac{1}{9}, \frac{1}{3}, \dots$
13. $\frac{1}{4}, \frac{1}{2}, -1, \dots$

Find the nth term of each geometric sequence.

14. $a_1 = 4, n = 3, r = 5$
15. $a_1 = 2, n = 5, r = 2$
16. $a_1 = 7, n = 4, r = 2$
17. $a_1 = 243, n = 5, r = -\frac{1}{3}$
18. $a_1 = 32, n = 6, r = -\frac{1}{2}$
19. $a_1 = 16, n = 8, r = \frac{1}{2}$

Find the missing geometric means.

20. 3, _____, _____, _____, 48
21. 1, _____, _____, 8
22. 8, _____, _____, _____, $\frac{1}{4}$
23. 3, _____, 75
24. 5, _____, _____, _____, 80
25. 7, _____, _____, _____, 112

26. A Ping-Pong ball is dropped from a height of 16 ft and always rebounds one-fourth of the distance fallen. How high does it rebound the 6th time?
27. A city has a current population of 100,000 and the population is increasing by 3% each year. What will the population be in 15th years?
28. A super ball dropped from the top of the tower (556 ft high) always rebounds three-fourths of the distance fallen. How far (up and down) will the ball have travelled when it hits the ground for the 6th time?
29. The teaching staff of high school informs its members of school cancellation by telephone. The principal calls 2 teachers, each of whom in turn calls 2 other teachers, and so on. In order to inform the entire staff, 6 rounds of calls are made. Counting the principal, find how many people are in staff at high school?
30. A 5-day rain caused the river to rise. After the first day, the river rose one inch. Each day the rise in the river tripled. How much had the river risen after 5 days?

4.5 Geometric Series

The sum of the terms of a geometric sequence is called a **geometric series**.

4.5.1 Sum of the First n Terms of a Geometric Sequence

We want to find a formula for S_n when sequence is geometric as given below.

$$a_1, a_1r^1, a_1r^2, a_1r^3, \dots, a_1r^{n-1}$$

The geometric series S_n (sum of n terms) is given by:

$$S_n = a_1 + a_1r^1 + a_1r^2 + a_1r^3 + \dots + a_1r^{n-2} + a_1r^{n-1} \quad (1)$$

If we multiply both sides of equation (1) by r , we have

$$rS_n = a_1r + a_1r^2 + a_1r^3 + \dots + a_1r^{n-1} + a_1r^n \quad (2)$$

Subtracting corresponding sides of equation (2) from equation (1), we get:

$$S_n - rS_n = a_1 - a_1r^n$$

or
$$S_n(1 - r) = a_1(1 - r^n)$$

Dividing on both sides by $1 - r$ gives the following formula:

The formula for finding the sum of n terms of geometric series:

$$S_n = \frac{a_1(1 - r^n)}{1 - r} \quad \text{for any } r \neq 1$$

Note: When $r = 1$, the denominator becomes zero. Therefore, the formula is applicable when $r \neq 1$.

Example:

Find the sum of the first 7 terms of the geometric sequence 3, 15, 75, 375, ...

Solution: First we note that:

$$a_1 = 3, n = 7, r = \frac{15}{3} \text{ or } 5$$

Using the formula for the sum of geometric series:

$$S_n = \frac{a_1(1-r^n)}{1-r}$$

$$S_7 = \frac{3(1-5^7)}{1-5} \quad (\text{Substituting values of } a_1, n \text{ and } r.)$$

$$= \frac{3(1-78,125)}{-4} = 58,593.$$

Key Facts

Another form of the formula for S_n can be developed and used, when we don't have number of terms.



$$a_n = a_1 r^{n-1}$$

$$a_n \cdot r = a_1 r^{n-1} \cdot r \quad (\text{Multiplying by 'r'})$$

$$a_n r = a_1 r^n \quad (i)$$

We have,

$$S_n = \frac{a_1 - a_1 r^n}{1-r}$$

$$S_n = \frac{a_1 - a_n r}{1-r} \quad (\text{Substituting value of } a_1 r^n)$$

Example: Find the sum of a geometric series for which $a_1 = 48$, $a_n = 3$ and $r = -\frac{1}{2}$.

Solution: Since we don't know n ,

$$S_n = \frac{a_1 - a_n r}{1-r}$$

$$S_n = \frac{48 - 3(-\frac{1}{2})}{1 - (-\frac{1}{2})} \quad (\text{Substituting } a_1 = 48, a_n = 3 \text{ and } r = -\frac{1}{2})$$

$$= \frac{48 + \frac{3}{2}}{1 + \frac{1}{2}} = 33$$

Example: Find a_1 in a geometric series where $S_7 = 3279$ and $r = 3$.

Solution: Now, Here $S_7 = 3297$, $r = 3$, $a_1 = ?$

$$\therefore S_n = \frac{a_1(1-r^n)}{1-r}$$

$$S_7 = \frac{a_1(1-r^7)}{1-r} \quad (\text{Taking } n = 7 \text{ to get } S_7).$$

$$3279 = \frac{a_1(1-3^7)}{1-3} \quad (\text{Substituting } r = 3)$$

$$3279 = \frac{a_1(1-2187)}{-2}$$

$$= \frac{3279(-2)}{-2186} = a_1 \quad (\text{Solve for } a_1)$$

$$\therefore a_1 = 3$$

4.5.2 Infinite Geometric Series

The first swing of a pendulum measures 25cm. The lengths of the successive swings of the pendulum form the geometric sequence 25, 20, 16, 12.8,...

Suppose the pendulum continues to swing back and forth indefinitely then the sequence shown above becomes an infinite geometric sequence.

The total distance the pendulum travels can be expressed as the infinite geometric series

$$25 + 20 + 16 + 12 + \dots$$

In the series, $a_1 = 25$ and $r = \frac{20}{25} = 0.8$

So, the series can be expressed as:

$$25 + 25 (0.8)^1 + 25 (0.8)^2 + 25 (0.8)^3 + 25 (0.8)^4 + \dots$$

Look for a pattern in the values of $(0.8)^n$ as n increases.

$$(0.8)^1 = 0.8, (0.8)^{10} = 0.107374, (0.8)^{50} = 0.0000143$$

In an infinite geometric series where $|r| < 1$, as the value of n increases infinitely, the value of r^n approaches 0. Therefore, substituting value of r^n in the formula:

$$S_n = \frac{a_1 (1 - r^n)}{1 - r},$$

we get: $S_\infty = \frac{a_1}{1 - r}$. This is formula for the sum of an infinite geometric series.

Sum of an Infinite Geometric Series

The sum, S_∞ , of an infinite geometric series where $-1 < r < 1$ is given by the following formula:

$$S_\infty = \frac{a_1}{1 - r}$$

Key Facts



An infinite geometric series in which $|r| > 1$ does not have a sum. For example, consider the series $1 + 2 + 4 + 8 + \dots$ where $a_1 = 1$ and $r = 2$. The terms of this series keep increasing, so the sum becomes greater with each additional term and never approaches to any point or number.

Example: Find the total distance travelled by the pendulum before coming to rest, if it successive swings form the geometric series:

$$25 + 20 + 16 + 12.8 + \dots$$

Solution: Sum of the infinite geometric series is given by:

$$S = 25 + 20 + 16 + 12.8 + \dots$$

Here $a_1 = 25$ and $r = 0.8$

$$S = \frac{a_1}{1 - r} = \frac{25}{1 - 0.8} = 125$$

Thus, the pendulum travels 125cm.

Example: Find the sum of the infinite geometric series $\frac{4}{3} - \frac{2}{3} + \frac{1}{3} - \frac{1}{6} + \dots$

Solution: To find the value of r , divide any term by its preceding term,

$$r = \frac{-2/3}{4/3} = -\frac{1}{2}$$

Since $|r| < 1$, we have $S_{\infty} = \frac{a_1}{1-r}$

$$S_{\infty} = \frac{4/3}{1-(-\frac{1}{2})} = \frac{8}{9}$$

Example: Find fractional notation for 0.63636363...

Solution: We can express this decimal as:

$$0.63636363\dots = 0.63 + 0.0063 + 0.000063 + \dots$$

This is an infinite geometric series, where $a_1 = 0.63$ and $r = 0.01$. Since $|r| < 1$, this series has a sum:

$$S_{\infty} = \frac{a_1}{1-r} = \frac{0.63}{1-0.01} = \frac{0.63}{0.99} = \frac{63}{99}$$

Thus, the fractional notation for 0.63636363... is $\frac{63}{99}$ or $\frac{7}{11}$.

Exercise 4.5

Find the sum of each geometric series.

1. $16 + 16 + 16 + \dots$ to 11 terms
2. $75 + 15 + 3 + \dots$ to 10 terms
3. $a_1 = 5, r = 3, n = 12$
4. $a_1 = 256, r = 0.75, n = 9$
5. $a_1 = 7, r = 2, n = 14$
6. $a_1 = 12, a_5 = 972, r = -3$
7. $a_1 = 16, r = -\frac{1}{2}, n = 10$
8. $a_1 = 243, r = -\frac{2}{3}, n = 5$
9. $a_1 = 343, a_4 = -1, r = -\frac{1}{7}$
10. $a_3 = \frac{3}{4}, a_6 = \frac{3}{32}, n = 6$

Find a_1 for each geometric series:

11. $S_n = 244, r = -3, n = 5$
12. $S_n = 32, r = 2, n = 6$
13. $a_n = 324, r = 3, S_n = 484$
14. Find fractional notation for the infinite geometric series.

| | | |
|----------------|-------------------|--------------------|
| (i) 0.444... | (ii) 9.99999... | (iii) 0.5555... |
| (iv) 0.6666... | (v) 0.15151515... | (vi) 0.12121212... |

15. To test its elasticity, a rubber ball is dropped into a 30ft hollow tube that is calibrated so that the scientist can measure the height of each subsequent bounce. The scientist found that on each bounce, the ball rises to a height $\frac{2}{5}$ the height of the previous bounce. How far will the ball travel before it stops bouncing?
16. A hot-air balloon rises 80ft in the first minute of flight. If in each succeeding minutes the balloon rises only 90% as far as in the previous minute, what will be its maximum altitude if it is allowed to rise without limit?

4.6 Harmonic Sequence

A sequence of numbers is called a harmonic sequence or harmonic progression (H.P.) if the reciprocals of its terms are in arithmetic progression.

For example, the sequence; $1, \frac{1}{4}, \frac{1}{8}, \frac{1}{11}, \dots$ is a harmonic sequence because the reciprocals of its terms are 1, 4, 8, 11, which form an arithmetic sequence.

4.6.1 The nth Term of a Harmonic Sequence

The sequence:

$$\frac{1}{a_1}, \frac{1}{a_1 + d}, \frac{1}{a_1 + 2d}, \dots \text{ is H.P.}$$

The reciprocals of the terms are:

$$a_1, a_1 + d, a_1 + 2d, \dots \text{ in A.P.}$$

We know that general term of A.P. is

$$a_n = a_1 + (n - 1) d$$

The reciprocals of the terms :

$$\frac{1}{a_n} = \frac{1}{a_1 + (n-1)d} \text{ (in H.P.)}$$

where a_1 and d are the first term and common difference of the corresponding A.P.

Example: Find the 9th term of the H.P. $\frac{1}{2}, \frac{1}{7}, \frac{1}{12}, \frac{1}{17}, \dots$

Solution:

$$\frac{1}{2}, \frac{1}{7}, \frac{1}{12}, \frac{1}{17}, \dots \text{ is H.P.}$$

The reciprocals of the terms 2, 7, 12, 17, ... are in A.P.

We have $a_1 = 2, d = 5, n = 9$

$$a_n = a_1 + (n - 1) d$$

$$a_9 = 2 + (9 - 1) 5$$

$$= 2 + 40 = 42 \text{ in A.P.}$$

Thus, the 9th term of the H.P. is $\frac{1}{42}$.

Example: Find the harmonic sequence, whose fourth term is $\frac{1}{13}$ and eleventh term is $\frac{1}{25}$.

Solution: The fourth and eleventh terms of H.P. are $\frac{1}{13}$ and $\frac{1}{25}$ respectively.

The reciprocals are in A.P. So,

$$\text{Fourth term (A.P.)} = a_4 = 13,$$

$$\text{and eleventh term (A.P.)} = a_{11} = 25$$

$$a_4 = 13 \Rightarrow a_1 + 3d = 13 \quad \text{(i)}$$

$$a_{11} = 25 \Rightarrow a_1 + 10d = 25 \quad \text{(ii)}$$

Solving (i) and (ii), we have

$$a_1 = 7 \text{ and } d = 2$$

Here, $a_1 = 7$
 $a_2 = a_1 + d = 7 + 2 = 9$
 $a_3 = a_1 + 2d = 7 + 2(2) = 11$
 $a_4 = a_1 + 3d = 7 + 3(2) = 13$

The arithmetic sequence is
 7, 9, 11, 13,.....

So, harmonic sequence is
 $\frac{1}{7}, \frac{1}{9}, \frac{1}{11}, \frac{1}{13}, \dots$

4.6.2 Harmonic Mean

A number H is said to be the harmonic mean (H.M.) between two numbers a and b if a, H, b are in H.P.

So, $\frac{1}{a}, \frac{1}{H}, \frac{1}{b}$ are in A.P.

Common difference = $\frac{1}{H} - \frac{1}{a} = \frac{1}{b} - \frac{1}{H}$

$$\frac{1}{H} + \frac{1}{H} = \frac{1}{a} + \frac{1}{b}$$

$$\frac{2}{H} = \frac{a+b}{ab}$$

$\Rightarrow H = \frac{2ab}{a+b}$ (Harmonic Mean)

This gives the formula for H.M. between a and b .

Example: Find the harmonic mean between 15 and 7.

Solution: Here $a = 15$ and $b = 7$, therefore

$$\begin{aligned} \text{H.M.} &= \frac{2(15)(7)}{15+7} \\ &= \frac{210}{22} = \frac{105}{11} \end{aligned}$$

4.6.3 Relations between Arithmetic, Geometric and Harmonic Means

(i) If A, G, H are the arithmetic, geometric and harmonic mean between two positive numbers a and b , then show that

$$A > G > H$$

We know that

$$A = \frac{a+b}{2} \quad (\text{Arithmetic Mean})$$

$$G = \sqrt{ab} \quad (\text{Geometric Mean})$$

$$H = \frac{2ab}{a+b} \quad (\text{Harmonic Mean})$$

❖ $A > G$ if $\frac{a+b}{2} > \sqrt{ab}$

We have $a + b > 2\sqrt{ab}$

$$a + b - 2\sqrt{ab} > 0$$

Key Facts

If a and b are negative real numbers then

$A < G < H$

We can write: $(\sqrt{a} + \sqrt{b} - 2\sqrt{ab}) > 0$

$$(\sqrt{a} - \sqrt{b})^2 > 0, \text{ always true}$$

$$\therefore A > G$$

$$\diamond G > H \text{ if } \sqrt{ab} > \frac{2ab}{a+b}$$

We can write: $a + b > \frac{2ab}{\sqrt{ab}}$

$$a + b > 2\sqrt{ab}$$

So, $a + b - 2\sqrt{ab} > 0 \Rightarrow (\sqrt{a} - \sqrt{b})^2 > 0, \text{ always true}$

$$\therefore G > H$$

Therefore, we have $A > G > H$

$$(ii) A \times H = G^2$$

$$\text{L.H.S.} = A \times H$$

$$= \frac{a+b}{2} \times \frac{2ab}{a+b}$$

$$= ab = (\sqrt{ab})^2 = G^2 = \text{R.H.S}$$

$$\therefore A \times H = G^2$$

Example: Find the arithmetic, geometric and harmonic means of 24 and 16.

Also show that $AH = G^2$.

Solution: Here $a = 24, b = 16$

$$A = \frac{a+b}{2} = \frac{24+16}{2} = 20 \text{ (A.M.)}$$

$$G = \sqrt{ab} = \sqrt{24 \times 16} = 8\sqrt{6} \text{ (G.M.)}$$

$$H = \frac{2ab}{a+b} = \frac{2(24)(16)}{24+16} = \frac{96}{5} \text{ (H.M.)}$$

We have $AH = G^2$

$$\text{L.H.S.} = A \times H = 20 \times \frac{96}{5} = 384$$

$$\text{R.H.S.} = G^2 = (8\sqrt{6})^2 = 64 \times 6 = 384$$

$$\therefore A \times H = G^2$$

Exercise 4.6

Find the indicated term of the harmonic progression (Q. 1-6).

1. $\frac{1}{9}, \frac{1}{12}, \frac{1}{15}, \dots$ 7th term

2. $\frac{1}{11}, \frac{1}{9}, \frac{1}{7}, \dots$ 10th term

3. $\frac{1}{18}, \frac{1}{13}, \frac{1}{8}, \dots$ 20th term

4. $\frac{1}{4}, \frac{1}{9}, \frac{1}{14}, \dots$ nth term

5. $\frac{1}{27}, \frac{1}{20}, \frac{1}{13}, \dots$ nth term

6. $\frac{1}{2}, \frac{1}{2\frac{1}{2}}, \frac{1}{3}, \frac{1}{3\frac{1}{2}}, \dots$ nth term

7. Find the 14th term of H.P. $\frac{1}{4}, \frac{1}{7}, \frac{1}{10}, \frac{1}{13}, \dots$

8. 7, 4, 1, is arithmetic sequence, find the 17th term in H.P.

9. Find the 8th term in H.P.

$$\frac{1}{7}, \frac{1}{6}, -1, -\frac{1}{3}, \dots$$

10. Find H.M. between 9 and 11. Also find A, H, G and show that $AH = G^2$.

11. Find H.M. between $\frac{2}{3}$ and $\frac{4}{7}$.

12. Find four H.Ms. between $\frac{1}{3}$ and $\frac{1}{11}$.

Note: Sum of Harmonic Progression Formula

Sum of n terms in HP;

For $\frac{1}{a} + \frac{1}{a+d} + \frac{1}{a+2d} + \dots + \frac{1}{a+(n-1)d}$

$$S_n \approx \frac{1}{d} \ln\left(\frac{2a+(2n-1)d}{2a-d}\right) \text{ (This is approximated sum for harmonic series)}$$

Where: ' a ' is the first term of A.P., ' d ' is the common difference of A.P., and " \ln " is the natural logarithm

4.7 Miscellaneous Series

A sequence is simply an ordered list. For example, when a baseball coach writes a batting order, a sequence is being formed. When the members of a sequence are numbers, we can find their sum. Such a sum is called a **series**.

4.7.1 Sigma Notation

When the general term of a sequence is known, the Greek letter Σ (Sigma) can be used to write a series. For example, the sum of the first four terms of the sequence 3, 5, 7, 9, ..., $2k + 1$, ... can be named as follows, using sigma notation or summation notation;

$$\sum_{k=1}^4 (2k + 1)$$

This is read as, "the sum as k goes from 1 to 4 of $(2k + 1)$." The letter k is called the **index** of summation. Sometimes the index of summation starts at a number other than 1.

Example: Find and evaluate the following sums.

a) $\sum_{k=1}^5 k^2$

b) $\sum_{k=1}^4 (-1)^k (2k)$

c) $\sum_{k=0}^3 (2^k + 5)$

Solution:

a) $\sum_{k=1}^5 k^2 = 1^2 + 2^2 + 3^2 + 4^2 + 5^2$

Evaluate k^2 for all integers from 1 to 5 and then add.

$$\therefore 1 + 4 + 9 + 16 + 25 = 55$$

b) $\sum_{k=1}^4 (-1)^k (2k) = (-1)^1 (2.1) + (-1)^2 (2.2) + (-1)^3 (2.3) + (-1)^4 (2.4)$
 $= -2 + 4 - 6 + 8 = 4$

c) $\sum_{k=0}^3 (2^k + 5) = (2^0 + 5) + (2^1 + 5) + (2^2 + 5) + (2^3 + 5)$
 $= 6 + 7 + 9 + 13 = 35$

Example: Write sigma notation for the sum.

a) $1 + 4 + 9 + 16 + 25$

b) $-1 + 3 - 5 + 7$

c) $3 + 9 + 27 + 81 + \dots$

Solution:

a) $1 + 4 + 9 + 16 + 25$

This is a sum of squares i.e. $1^2 + 2^2 + 3^2 + 4^2 + 5^2$. So, the general term is k^2 and its sigma notation is,

$$\sum_{k=1}^5 k^2$$

b) $-1 + 3 - 5 + 7$

Except for the alternating signs, this is the sum of the first four positive odd numbers.

Note that $2k - 1$ is a formula for the k th positive odd number and $(-1)^k = 1$, when k is even and $(-1)^k = -1$, when k is odd.

The general term is thus $(-1)^k (2k - 1)$, beginning with $k = 1$.

So, its sigma notation is:

$$\sum_{k=1}^4 (-1)^k (2k - 1)$$

c) $3 + 9 + 27 + 81 + \dots$

This is the sum of powers of 3, and it is also an infinite series. We use the symbol ∞ to represent infinity and name the infinite series using sigma notation as follows:

$$\sum_{k=1}^{\infty} 3^k$$

4.7.2 Some Important Results

The sum of the first n natural numbers, the sum of squares of the first n natural numbers and the sum of the cubes of the first n natural numbers are expressed in sigma notation as:

$$\sum_{k=1}^n k = 1 + 2 + 3 + 4 + \dots + n$$

$$\sum_{k=1}^n k^2 = 1^2 + 2^2 + 3^2 + 4^2 + \dots + n^2$$

$$\sum_{k=1}^n k^3 = 1^3 + 2^3 + 3^3 + 4^3 + \dots + n^3$$

We evaluate $\sum_{k=1}^n [k^m - (k-1)^m]$ for any positive integer m and shall use this result to find out formulas for three expressions stated above.

$$\begin{aligned} \sum_{k=1}^n [k^m - (k-1)^m] &= (1^m - 0^m) + (2^m - 1^m) + (3^m - 2^m) + \dots \\ &\quad + [(n-1)^m - (n-2)^m] + [n^m - (n-1)^m] \\ &= 1^m - 0^m + 2^m - 1^m + 3^m - 2^m + \dots + (n-1)^m - (n-2)^m + n^m - (n-1)^m \\ &= n^m \quad \text{[only } n^m \text{ will left, all other terms will be cancelled out]} \end{aligned}$$

Thus, $\boxed{\sum_{k=1}^n [k^m - (k-1)^m] = n^m}$ (i)

If $m = 1$, the equation (i) will become

$$\begin{aligned} \sum_{k=1}^n [k^1 - (k-1)^1] &= n^1 \\ \sum_{k=1}^n [k - k + 1] &= n \end{aligned}$$

$$\boxed{\sum_{k=1}^n 1 = n} \quad \text{[Means; } 1 + 1 + 1 + \dots + 1 = n \text{]} \\ \text{(n times)}$$

When $m = 2$, the equation (i) will become

$$\begin{aligned} \sum_{k=1}^n [k^2 - (k-1)^2] &= n^2 \\ \sum_{k=1}^n [k^2 - k^2 + 2k - 1] &= n^2 \\ \sum_{k=1}^n [2k - 1] &= n^2 \\ 2 \sum_{k=1}^n k - \sum_{k=1}^n 1 &= n^2 \\ 2 \sum_{k=1}^n k - n &= n^2 \quad (\because \sum_{k=1}^n 1 = n) \end{aligned}$$

$$\begin{aligned} 2 \sum_{k=1}^n k &= n^2 + n \\ \sum_{k=1}^n k &= \frac{n^2 + n}{2} \end{aligned}$$

$$\boxed{\sum_{k=1}^n k = \frac{n(n+1)}{2}}$$

Key Facts

$$\Sigma(a + b) = \Sigma a + \Sigma b$$

$$\Sigma 3a = 3 \Sigma a$$

Taking $m = 3$ in equation (i), we have

$$\begin{aligned} \sum_{k=1}^n [k^3 - (k-1)^3] &= n^3 \\ \sum_{k=1}^n [3k^2 - 3k + 1] &= n^3 \end{aligned}$$

$$3 \sum_{k=1}^n k^2 - 3 \sum_{k=1}^n k + \sum_{k=1}^n 1 = n^3$$

We have, $\sum_{k=1}^n 1 = n$; $\sum_{k=1}^n k = \frac{n(n+1)}{2}$

$$\begin{aligned} 3 \sum_{k=1}^n k^2 - 3 \frac{n(n+1)}{2} + n &= n^3 \\ 3 \sum_{k=1}^n k^2 &= n^3 - n + \frac{3n(n+1)}{2} \end{aligned}$$

$$\begin{aligned}
 &= \frac{2n^3 - 2n + 3n^2 + 3n}{2} \\
 &= \frac{2n^3 + 3n^2 + n}{2} \\
 &= \frac{n(2n^2 + 3n + 1)}{2} \\
 &= \frac{n(2n^2 + 2n + n + 1)}{2} \\
 &= n \left[\frac{2n^2 + 2n + n + 1}{2} \right] \\
 &= n \left[\frac{2n(n+1) + 1(n+1)}{2} \right] \\
 3 \sum_{k=1}^n k^2 &= \frac{n(n+1)(2n+1)}{2}
 \end{aligned}$$

$$\boxed{\sum_{k=1}^n k^2 = \frac{n(n+1)(2n+1)}{6}}$$

Similarly, we can prove that

$$\sum_{k=1}^n k^3 = \left[\frac{n(n+1)}{2} \right]^3$$

Example: Find the sum of the n terms of the series

$$1.2 + 2.3 + 3.4 + \dots$$

Solution: We know that the general term of

$$1 + 2 + 3 + \dots \text{ is } k.$$

$$2 + 3 + 4 + \dots \text{ is } k + 1.$$

If T_k is the k th term or general term of the series, then:

$$T_k = k(k+1)$$

$$T_k = k^2 + k$$

To find sum, taking summation both sides:

$$\begin{aligned}
 \sum_{k=1}^n T_k &= \sum_{k=1}^n k^2 + k \\
 &= \sum_{k=1}^n k^2 + \sum_{k=1}^n k \\
 &= \frac{n(n+1)(2n+1)}{6} + \frac{n(n+1)}{2} \\
 &= \frac{n(n+1)}{2} \left[\frac{2n+1}{3} + 1 \right] \\
 &= \frac{n(n+1)(2n+4)}{6}
 \end{aligned}$$

$$\sum_{k=1}^n T_k = \frac{n(n+1)(n+2)}{3}$$

$$\boxed{\left[\sum k = \frac{n(n+1)}{2} \right] \text{ and}}$$

$$\boxed{\sum k^2 = \frac{n(n+1)(2n+1)}{6}}$$

Example: Find the sum to n terms of the series whose n th term is $n^2 + 4n + 1$.

Solution: Replace n with k .

$$T_k = k^2 + 4k + 1$$

Taking summation

$$\sum T_k = \sum (k^2 + 4k + 1)$$

$$\begin{aligned}
 &= \sum k^2 + 4 \sum k + \sum 1 \\
 &= \frac{n(n+1)(2n+1)}{6} + 4 \frac{n(n+1)}{2} + n \\
 &= n \left[\frac{(n+1)(n+2)}{6} + 2(n+1) + 1 \right] \\
 &= n \left[\frac{n^2 + 2n + n + 2 + 12n + 12 + 6}{6} \right] \\
 \sum T_k &= n \left[\frac{n^2 + 15n + 20}{6} \right]
 \end{aligned}$$

4.8 Arithmetico-Geometric Series

In mathematics, arithmetico-geometric sequence is the result of term-by-term multiplication of a geometric progression with the corresponding terms of arithmetic progression. The n th term of an arithmetico-geometric sequence is the product of the n th term of an arithmetic sequence and the n th term of a geometric sequence. Arithmetico-geometric sequence arise in various applications such as the computation of expected values in statistics and other fields. For instance the sequence

$$\frac{0}{1}, \frac{1}{2}, \frac{2}{4}, \frac{3}{8}, \frac{4}{16}, \frac{5}{32}, \dots$$

is an arithmetico-geometric sequence. The arithmetic component appears in the numerator and geometric one in the denominator.

The summation of this infinite sequence is known as **arithmetico-geometric series**.

4.8.1 Terms of the Sequence

The first few terms of an arithmetico-geometric sequence composed of an arithmetic progression with common difference d and initial value a and geometric progression with initial value b and common ratio r are given by:

$$\begin{aligned}
 T_1 &= ab = A_1 G_1 \\
 T_2 &= (a + d) br = A_2 G_2 \\
 T_3 &= (a + 2d) br^2 = A_3 G_3 \\
 &\vdots \\
 &\vdots \\
 &\vdots \\
 T_n &= \underbrace{[a + (n-1)d]}_{A_n} \underbrace{br^{n-1}}_{G_n} = A_n G_n
 \end{aligned}$$

For example, in the sequence $\frac{0}{1}, \frac{1}{2}, \frac{2}{4}, \frac{3}{8}, \frac{4}{16}, \frac{5}{32}, \dots$ $d = 1, a = 0, b = 1$ and $r = \frac{1}{2}$.

Then n th term is:

$$\begin{aligned}
 T_n &= [0 + (n-1)1] 1 \cdot \left(\frac{1}{2}\right)^{n-1} \\
 T_n &= (n-1) \left(\frac{1}{2}\right)^{n-1} \\
 T_n &= \frac{n-2}{2^{n-1}}
 \end{aligned}$$

4.8.2. Sum of the n Terms

The sum of the first n terms of an arithmetico-geometric sequence has the form:

$$S_n = \sum_{k=1}^n T_k = \sum_{k=1}^n [a + (k-1)d] br^{k-1}$$

$$= ab + (a+d)br + (a+2d)br^2 + \dots + [a + (n-1)d] br^{n-1} \quad (i)$$

$$S_n = A_1G_1 + A_2G_2 + A_3G_3 + \dots + A_nG_n$$

This sum can be written in closed form.

Proof:

Equation (i), is written as by putting $b = 1$

$$S_n = a + (a+d)r + (a+2d)r^2 + \dots + [a + (n-1)d] r^{n-1} \quad (ii)$$

Multiplying both sides of equation (ii) by r .

$$rS_n = ar + (a+d)r^2 + (a+2d)r^3 + (a+3d)r^4 + \dots + [a + (n-1)d] r^n \quad (iii)$$

Subtracting rS_n from S_n and using the technique of telescope, we get:

$$S_n - rS_n = [a + (a+d)r + (a+2d)r^2 + \dots + [a + (n-1)d] r^{n-1}]$$

$$- [ar + (a+d)r^2 + (a+2d)r^3 + (a+3d)r^4 + \dots + [a + (n-1)d] r^n]$$

$$= a + ar + dr + ar^2 + 2dr^2 + \dots + ar^{n-1} + (n-1)dr^{n-1}$$

$$- ar - ar^2 - dr^2 - ar^3 - 2dr^3 - \dots - ar^n - (n-1)dr^n$$

After cancelling like terms, we have:

$$= a + d(r + r^2 + r^3 + \dots + r^{n-1}) - [a + (n-1)d] r^n$$

$$= a + d(r + r^2 + r^3 + \dots + r^{n-1}) - ar^n - ndr^n + dr^n$$

$$S_n - rS_n = a + d(r + r^2 + r^3 + \dots + r^{n-1} + r^n) - (a + nd)r^n$$

$$(1-r)S_n = a + dr(1 + r + r^2 + \dots + r^{n-1}) - (a + nd)r^n$$

$$(1-r)S_n = a + dr \frac{(1-r^n)}{1-r} - (a + nd)r^n$$

Note

To generate the formula for finding the sum of the n th term " S_n ", we take $b = 1$.

$$S_n = \frac{a}{1-r} + dr \frac{(1-r^n)}{(1-r)^2} - \frac{(a + nd)r^n}{1-r} \quad (iv)$$

Hence, a is first term and d is common difference of arithmetic series and r is common ratio of geometric series.

4.8.3 Sum to Infinite Terms of Arithmetico-Geometric Series

Let $|r| < 1$

We know that $r^n \rightarrow 0$ as $n \rightarrow \infty$, then equation (iv) will become

$$S_\infty = \frac{a}{1-r} + \frac{dr}{(1-r)^2}$$

This is sum to infinity of arithmetico-geometric series.

Example: Find the sum of $1 + \frac{3}{2} + \frac{5}{4} + \frac{7}{8} + \dots$ to n terms.

Solution: We know that the sum of arithmetic-geometric series formula for n terms is

$$S_n = \frac{a}{1-r} + dr \frac{(1-r^n)}{(1-r)^2} - \frac{(a+nd)r^n}{1-r} \quad (a)$$

We need the value of a (1st term) and d (common difference) for arithmetic series and r (common ratio) for geometric series.

Given series is:

$$1 + \frac{3}{2} + \frac{5}{4} + \frac{7}{8} + \dots \text{ to } n \text{ terms}$$

We can rearrange as:

$$1 \cdot \frac{1}{1} + 3 \cdot \frac{1}{2} + 5 \cdot \frac{1}{4} + 7 \cdot \frac{1}{8} + \dots \text{ to } n \text{ terms}$$

It can be guessed that 1, 3, 5, 7, ... is arithmetic sequence with $a = 1, d = 2$, and $\frac{1}{1}, \frac{1}{2}, \frac{1}{4}, \frac{1}{8}, \dots$ is geometric sequence with $r = \frac{1}{2}$.

Substituting the value of $a = 1, d = 2$ and $r = \frac{1}{2}$, we get:

$$\begin{aligned} S_n &= \frac{1}{1-\frac{1}{2}} + 2 \cdot \frac{1}{2} \cdot \frac{(1-\frac{1}{2}^n)}{(1-\frac{1}{2})^2} - \frac{(1+2n)\frac{1}{2}^n}{1-\frac{1}{2}} \\ &= \frac{1}{\frac{1}{2}} + 1 \cdot \frac{(1-\frac{1}{2}^n)}{\frac{1}{4}} - \frac{(1+2n)\frac{1}{2}^n}{\frac{1}{2}} \\ &= 2 + 4 \left(1 - \frac{1}{2^n}\right) - 2(1+2n)\frac{1}{2^n} \\ &= 2 + 4 - \frac{4}{2^n} - 2(1+2n)\frac{1}{2^n} \\ &= 6 - \frac{1}{2^n}(4 + 2 + 4n) \\ &= 6 - \frac{2}{2^n}(3 + 2n) \\ S_n &= 6 - \frac{2n+3}{2^{n-1}} \end{aligned}$$

Example: Find the sum to infinity of the arithmetic-geometric series:

$$1 + \frac{2}{3} + \frac{3}{9} + \frac{4}{27} + \frac{5}{81} + \dots$$

Solution: Given arithmetic-geometric series can be written as:

$$1 \times 1 + 2 \times \frac{1}{3} + 3 \times \frac{1}{9} + 4 \times \frac{1}{27} + 5 \times \frac{1}{81} + \dots$$

The numbers 1, 2, 3, 4, 5, ... are in A.P. with $a = 1$ and $d = 1$.

Similarly, the numbers $1, \frac{1}{3}, \frac{1}{9}, \frac{1}{27}, \frac{1}{81}, \dots$ are in G.P. with first term as 1 and $r = \frac{1/3}{1} = \frac{1}{3}$.

Thus, sum to infinity of the arithmetico-geometric series for

$$1 + 2 \times \frac{1}{3} + 3 \times \frac{1}{9} + 4 \times \frac{1}{27} + 5 \times \frac{1}{81} + \dots \text{ is:}$$

$$S_\infty = \frac{a}{1-r} + \frac{dr}{(1-r)^2}$$

Here $a = 1, d = 1, r = \frac{1}{3}$

We have, $S_{\infty} = \frac{1}{1-\frac{1}{3}} + \frac{1\frac{1}{3}}{\left(1-\frac{1}{3}\right)^2}$
 $S_{\infty} = \frac{1}{\frac{2}{3}} + \frac{1}{3} \cdot \frac{1}{\left(\frac{2}{3}\right)^2}$
 $S_{\infty} = \frac{3}{2} + \frac{3}{4} = \frac{9}{4}$

Exercise 4.7

Evaluate the sum:

1. $\sum_{k=1}^5 \frac{1}{2k}$

2. $\sum_{k=1}^6 \frac{1}{2k+1}$

3. $\sum_{k=0}^5 2^k$

4. $\sum_{k=0}^9 \pi k$

5. $\sum_{k=1}^8 \frac{k}{k+1}$

6. $\sum_{k=1}^7 (-1)^k 4^{k+1}$

7. $\sum_{k=0}^5 (k^2 - 2k + 3)$

8. $\sum_{k=1}^{10} \frac{1}{k(k+1)}$

Rewrite the sum using sigma notation:

9. $\frac{1}{2} + \frac{2}{3} + \frac{3}{4} + \frac{4}{5} + \frac{5}{6} + \dots$

10. $3 + 6 + 9 + 12 + 15$

11. $-2 + 4 - 8 + 16 - 32 + 64$

12. $\frac{1}{1 \cdot 2} + \frac{1}{2 \cdot 3} + \frac{1}{3 \cdot 4} + \frac{1}{4 \cdot 5} + \dots$

13. Prove that $\sum_{k=1}^n k^3 = \left[\frac{n(n+1)}{2}\right]^3$

Find the sum to n terms of the series whose n th terms are given:

14. $n + 1$

15. $n^2 + 2n$

16. $3n^2 + 2n + 1$

Sum the following series up to n terms:

17. $2^2 + 5^2 + 8^2 + \dots$

18. $2^2 + 4^2 + 6^2 + \dots$

19. $1^3 + 3^3 + 5^3 + \dots$

20. $2 + 5 + 10 + 17 + \dots$ to n terms

21. $1 \times 4 + 2 \times 7 + 3 \times 10 + \dots$

22. $1 \times 3 \times 5 + 3 \times 5 \times 7 + 5 \times 7 \times 9 + \dots$ to n terms

Sum to n terms of the following series (arithmetico-geometric series):

23. $1 + 2 \times 2 + 3 \times 2^2 + 4 \times 2^3 + \dots$

24. $1 + 4y + 7y^2 + 10y^3 + \dots$

25. $1 + \frac{4}{7} + \frac{7}{7^2} + \frac{10}{7^3} + \dots$

26. $1 + \frac{7}{2} + \frac{13}{4} + \frac{19}{8} + \frac{25}{16} + \dots$

Find sum to infinity of the following series:

27. $5 + \frac{7}{3} + \frac{9}{9} + \frac{11}{27} + \dots$

28. $1 + \frac{2}{5} + \frac{3}{25} + \frac{4}{125} + \dots$

29. $1 + 4x + 7x^2 + 10x^3 + \dots$

30. $3 + \frac{6}{10} + \frac{9}{100} + \frac{12}{1000} + \dots$

4.9 Methods of Difference

If the differences of the successive term of a series are in A.P. or G.P., we can find n th term of the series by the following steps:

- Denote the n th term by T_n and sum of the series up to n terms by S_n .
- Rewrite the given series with each term shifted by one place to the right.
- Then subtract the second expression of S_n from the first expression to obtain T_n .

Example: Find the sum of the series:

$$7 + 12 + 20 + 31 + 45 + 62 + \dots \text{ up to } n \text{ terms}$$

Solution: Let

$$S_n = 7 + 12 + 20 + 31 + 45 + 62 + \dots + T_n$$

Also $S_n = 7 + 12 + 20 + 31 + 45 + \dots + T_{n-1} + T_n$

Subtracting second expression from the first expression, we have

$$S_n - S_n = 7 + 12 + 20 + 31 + 45 + 62 + \dots$$

$$+ T_n - (7 + 12 + 20 + 31 + 45 + \dots + T_{n-1} + T_n)$$

$$0 = 7 + (12 - 7) + (20 - 12) + (31 - 20) + (45 - 31) + \dots + (T_n - T_{n-1}) - T_n$$

'7' of 1st expression and T_n of second expression will be left as single.

We get

$$0 = 7 + (5 + 8 + 11 + 14 + 17 + \dots \text{ up to } (n - 1) \text{ terms}) - T_n$$

Then

$$T_n = 7 + (5 + 8 + 11 + 14 + 17 + \dots \text{ up to } (n - 1) \text{ terms})$$

$$T_n = 7 + \frac{n-1}{2} [2(5) + (n-1-1)3] \quad (\because S_n = \frac{n}{2} [2a + (n-1)d])$$

$$= 7 + \frac{n-1}{2} [10 + (n-2)3]$$

$$= 7 + \frac{n-1}{2} [3n + 4]$$

$$= \frac{14 + (n-1)(3n+4)}{2}$$

$$= \frac{14 + 3n^2 + 4n - 3n - 4}{2}$$

$$T_n = \frac{3n^2 + n + 10}{2}$$

So,

$$S_n = \sum T_n = \sum \frac{3n^2 + n + 10}{2}$$

$$= \frac{3}{2} \sum n^2 + \frac{1}{2} \sum n + \frac{10}{2} \sum 1$$

$$= \frac{3}{2} \cdot \frac{n(n+1)(2n+1)}{6} + \frac{1}{2} \cdot \frac{n(n+1)}{2} + 5n$$

$$= \frac{n}{4} [(n+1)(2n+1) + n + 1 + 20]$$

$$S_n = \frac{n}{4} [n^2 + 2n + 11]$$

Example: Find the n th term and sum of n terms of the series:

$$1 + 3 + 7 + 15 + 31 + \dots$$

Solution: Let n th term and sum of n terms of the series be T_n and S_n respectively.

$$S_n = 1 + 3 + 5 + 7 + 15 + 31 + \dots + T_{n-1} + T_n \quad (i)$$

Also,

$$S_n = 1 + 3 + 5 + 7 + 15 + 31 + \dots + T_{n-2} + T_{n-1} + T_n \quad (ii)$$

Subtracting (i) and (ii), we have

$$0 = 1 + (3 - 1) + (7 - 3) + (15 - 7) + (31 - 15) + \dots + (T_n - T_{n-1}) + T_n$$

We get

$$T_n = 1 + 2 + 4 + 8 + 16 + \dots \text{ up to } (n-1) \text{ terms}$$

and

$$T_n = 1 + 2 + 4 + 8 + 16 + \dots \text{ up to } n \text{ terms}$$

This is a geometric series with $a = 1, r = 2, n = n$

$$T_n = 1 \cdot \frac{(2^n - 1)}{2 - 1} \quad \left(\because S_n = \frac{r^n - 1}{r - 1} \right)$$

$$T_n = 2^n - 1$$

$$S_n = \sum T_n = \sum (2^n - 1)$$

$$= \sum 2^n - \sum 1$$

$$= 2 + 2^2 + 2^3 + \dots + 2^n - n$$

$$= \frac{2(2^n - 1)}{2 - 1} - n$$

$$S_n = 2(2^n - 1) - n$$

4.9.1 Summation of Series by Partial Fractions

This method is used to find the sum of series $T_1 + T_2 + T_3 + \dots$ up to n terms, when each term T_n can be expressed as the difference of two consecutive terms of a new series i.e.

$$T_n = V_n - V_{n-1}$$

$$\Rightarrow S_n = \sum T_n = (V_1 - V_0) + (V_2 - V_1) + (V_3 - V_2) + \dots + (V_n - V_{n-1})$$

$$S_n = V_n - V_0$$

We can convert rational algebraic fractions into partial fractions, which can be written as a difference of two or more fractions in such a way that an addition of the fractions in successive

terms cancel. This is also called **telescoping series**. This technique will be used to find the sum of given series.

Example: Find the sum of n th term $T_n = \frac{1}{n(n+1)}$.

Solution: Given n th term is

$$T_n = \frac{1}{n(n+1)}$$

First, we will convert into partial fractions.

$$\frac{1}{n(n+1)} = \frac{A_1}{n} + \frac{A_2}{n+1}$$

This implies that: $1 = A_1(n+1) + A_2n$

After comparing coefficient, we have

$$A_1 = 1, \quad A_2 = -1$$

We have

$$\begin{aligned} \frac{1}{n(n+1)} &= \frac{1}{n} - \frac{1}{n+1} \\ \sum_{k=1}^n T^k &= \sum_{k=1}^n \frac{1}{k(k+1)} \\ &= \sum_{k=1}^n \frac{1}{k} - \sum_{k=1}^n \frac{1}{k+1} \end{aligned}$$

Applying sigma property, we have:

$$= \left[\left(1 - \frac{1}{2}\right) + \left(\frac{1}{2} - \frac{1}{3}\right) + \left(\frac{1}{3} - \frac{1}{4}\right) + \dots + \left(\frac{1}{n} - \frac{1}{n+1}\right) \right]$$

After cancelling like terms, we have:

$$\begin{aligned} \sum_{k=1}^n T^k &= \left(1 - \frac{1}{n+1}\right) = \frac{n+1-1}{n+1} = \frac{n}{n+1} \\ S_n &= \frac{n}{n+1} \end{aligned}$$

Example: Find the sum of the series

$$\frac{1}{1 \cdot 3} + \frac{1}{3 \cdot 5} + \frac{1}{5 \cdot 7} + \dots \text{ to infinity.}$$

Solution: The given series is

$$\frac{1}{1 \cdot 3} + \frac{1}{3 \cdot 5} + \frac{1}{5 \cdot 7} + \dots \text{ to infinity} \quad (i)$$

Here, 1, 3, 5... are in A.P., with $a = 1, d = 2$, whose general term is:

$$a + (n-1)d = 1 + (n-1)(2) = 2n - 1$$

Similarly, for 3, 5, 7... $a = 3, d = 2$, and the general term is:

$$a + (n-1)d = 3 + (n-1)(2) = 2n + 1$$

The n th term of (i) is,

$$T_n = \frac{1}{(2n-1)(2n+1)}$$

To find sum of infinity

$$S_\infty = \sum_{k=1}^{\infty} T^k = \sum_{k=1}^{\infty} \frac{1}{(2k-1)(2k+1)} \quad (ii)$$

We make partial fractions of $\frac{1}{(2k-1)(2k+1)}$ and write the expression as:

$$\frac{1}{(2k-1)(2k+1)} = \frac{1}{2} \left[\frac{1}{2k-1} - \frac{1}{2k+1} \right]$$

Equation (ii), can be written as:

$$\begin{aligned} S_{\infty} &= \sum_{k=1}^{\infty} T^k = \sum_{k=1}^{\infty} \frac{1}{2} \left[\frac{1}{2k-1} - \frac{1}{2k+1} \right] \\ &= \frac{1}{2} \sum_{k=1}^{\infty} \left[\frac{1}{2k-1} - \frac{1}{2k+1} \right] \\ &= \frac{1}{2} \left[\left(\frac{1}{1} - \frac{1}{3} \right) + \left(\frac{1}{3} - \frac{1}{5} \right) + \left(\frac{1}{5} - \frac{1}{7} \right) + \dots \right] \\ &= \frac{1}{2} [1] = \frac{1}{2} \end{aligned}$$

Sum of infinite series is $\frac{1}{2}$.

Exercise 4.8

Using the method of difference, find the sum of the following series:

1. $3 + 7 + 13 + 21 + \dots$ to n terms
2. $1 + 4 + 10 + 22 + \dots$ to n terms
3. $1 + 4 + 13 + 40 + 121 + \dots$ to n terms
4. $1 + 2 + 4 + 7 + 11 + 16 + \dots$ to n terms
5. $3 + 4 + 6 + 10 + 18 + 34 + 66 + \dots$ to n terms
6. $1 + 4 + 8 + 14 + 24 + 42 + 76 + \dots$ to n terms

Find the sum of n terms of the series:

7. $\frac{1}{1 \times 4} + \frac{1}{4 \times 7} + \frac{1}{7 \times 10} + \dots$
8. $\frac{1}{1 \times 6} + \frac{1}{6 \times 11} + \frac{1}{11 \times 16} + \dots$

Evaluate the sum of the following series:

9. $\frac{1}{1 \cdot 3} + \frac{1}{2 \cdot 5} + \frac{1}{3 \cdot 7} + \dots$ up to ∞
10. $\sum_{k=3}^n \frac{1}{(k+1)(k+2)}$
11. $\sum_{k=1}^n \frac{1}{k(k+2)}$
12. $\frac{1}{1 \cdot 4} + \frac{1}{4 \cdot 7} + \frac{1}{7 \cdot 10} + \dots$ to infinity
13. $\frac{1}{5 \cdot 11} + \frac{1}{7 \cdot 13} + \frac{1}{9 \cdot 15} + \dots$ to n terms
14. $\sum_{k=1}^n \frac{1}{9k^2 + 2k - 2}$
15. $\sum_{k=2}^n \frac{1}{k^2 - k}$

4.10 Applications of Sequence and Series

Sequences and series have their own importance in many areas of Mathematics such as finance, statistics, population growth and physics. Most of the society and reality around us is based upon sequence after sequence, changing and repeating themselves over and over again. Common examples of this are time and calendrical system. Time (seconds, minutes, hours) always follow the same sequence, which always contains the same number of elements. Our lives are ruled over by sequences such as the routines that we follow every day without knowing leading to their great importance in the structure and function of the modern world.

Example: Khalid is saving for a new car. He deposits Rs. 100,000 into his account and then each month he deposits in Rs. 10,000 more than the month before. If the price of the car is Rs.1,260,000; find:

- The amount Khalid has saved in four months.
- The time in which Khalid reaches his goal of Rs. 1,260,000.

Solution:

- Since Khalid deposits same amount every month, therefore, we will use arithmetic series.

$$\text{Let } a_1 = 100000, d = 10000, S_4 = ?$$

$$S_n = \frac{n}{2}[2a + (n-1)d]$$

$$S_4 = \frac{4}{2}[2(a) + (4-1)d]$$

$$S_4 = 2[2(100000) + (3)10000]$$

$$S_4 = 2[200000 + 30000]$$

$$S_4 = 460000$$

Therefore, amount saved in 4 months = Rs. 460,000

- Let $S_n = 126,0000, d = 10000, a = 100000, n = ?$

$$S_n = \frac{n}{2}[2a + (n-1)d]$$

$$126,0000 = \frac{n}{2} [2(100000) + (n-1)10000]$$

$$= n[190000n + 100000]$$

$$2520000 = 190000n + 10000n^2$$

$$n^2 + 19n - 252 = 0$$

$$n^2 + 28n - 9n - 252 = 0$$

$$n(n + 28) - 9(n + 28) = 0$$

$$(n - 9)(n + 28) = 0$$

$$n = 9, n = -28 \text{ (n cannot be negative)}$$

∴ Khalid will reach Rs. 1,200,000 in the 9th month.

Example: A new virus is on a remote area. On day one, there were 10 people infected, with the number of new infections increasing at a rate of 40% per day.

- i. Find the expected number of infected people on the 7th day.
- ii. Find the expected number of infected people during week (7 days).

Solution:

- i. As the infection is increasing in percentage, therefore it is the problem of geometric sequence series.

Let $a_1 = 10$, $r = 1.4$ [40% increasing so $r = (100 + 40)\% = 140\% = 1.4$], $a_7 = ?$

Formula for nth term of a geometric progression.

$$a_n = ar^{n-1}$$

$$a_7 = ar^6$$

$$a_7 = 10(1.4)^6$$

$$a_7 = 75.29$$

∴ Expected number of new infections = 75 after seven days

- ii. Total infected people after one week are S_7 .

$$S_n = \frac{a(r^n - 1)}{r - 1}; r > 1$$

$$S_7 = \frac{a(r^7 - 1)}{r - 1}$$

$$S_7 = \frac{10(1.4^7 - 1)}{1.4 - 1}$$

$$S_7 = 238.53$$

∴ Expected number of total infections = 239

Exercise 4.9

- 1. A rocket rises 20 feet in the first second, 60 feet in the 2nd second and 100 feet in the third second. If it continues at this rate, how many feet will it rise in the 20th second?
- 2. On the results declaration day, the school wants to invite parents as well as students. Auditorium has 21 seats in the first row and each of the other rows has one more seat than the one in front of it. There are 30 rows of seats in total. If they anticipate that 1200 people will come that day, will there be a seat for everyone? Justify your answer.
- 3. Majid retired after 30 years of employment. If his salary was Rs. 4500 in the first year and he received an increment of Rs. 820 at the end of each year of service. What was his total salary after 30 years?

4. You save Rs. 1 in the first day. Then each day thereafter, save double the amount you saved the day before. Find the amount you should save in the 20th day of your plan.
5. A vacuum pump removes $\frac{1}{5}$ of the air from a sealed container on each stroke of its piston. What percent of the air remains after five strokes of the piston?
6. Aslam borrows Rs. 20000 at 11% interest compounded annually. If he pays off the loan in full at the end of four years, how much does he pay?
7. A property dealer estimates that a piece of land will increase its value at a rate of 10% each year. If the original value of land is Rs. 450000, what will be its value in 8 years?
8. A man deposits in a bank Rs. 2000 in the first year, Rs. 4000 in the second year, Rs. 8000 in the third year and so on. Find the amount he will have deposited in the bank by the fifth year.
9. The number of bacteria in a culture increased geometrically from 16000 to 1215000 in 5 days. Find the daily rate of increase assuming the rate to be constant.
10. A car loan is in the amount of Rs. 600000 from the bank. Interest is 9% compounded annually and the entire amount is to be paid after 10 years. How much is to be paid back?
11. Zain bought a new car and got policy from insurance company. He will pay 5000 the first year, 6125 the second year, 7250 the third year and so on, for 10 years. How much he will pay to insurance company for vehicle?
12. Naveed takes a vehicle from bank after paying down payment. He deposits Rs. 13000 in a bank in first month, Rs. 14500 in the second month, Rs. 16000 in the third month and so on. Find how much total amount he has to deposit in the bank at the end of two years.
13. A man borrows a loan Rs. 1000000 for leasing a car and agrees to repay with a total 20 installments. Each installment is less than the preceding by Rs. 2000. What is his first installment?
14. Sara pays her first installment Rs. 8000 to insurance company for the vehicle. Each installment will increase by 5%. What total amount she will pay in 24 installments?

I have Learnt

- Defining an arithmetic sequence and finding its general term.
- Knowing arithmetic mean between two numbers. Also insert n arithmetic means between them.
- Defining an arithmetic series and establishing the formula to find the sum to n terms of the series.
- Showing that sum of n arithmetic means between two numbers is equal to n times their AM.
- Solving real life problems involving arithmetic sequence, arithmetic mean and arithmetic series.
- Defining a geometric sequence and finding its general term.
- Knowing geometric mean between two numbers. Also inserting n geometric means between them.
- Defining a geometric series and finding the sum of n terms of a geometric series.
- Finding the sum of an infinite geometric series.

- (ix) Geometric means between 1 and $\frac{1}{3}$ is:
 a. 3 b. $\frac{1}{\sqrt{3}}$ c. $\sqrt{3}$ d. $\frac{1}{3}$
- (x) $\sum_{k=1}^3 k^2$ is equal to:
 a. 14 b. 13 c. 5 d. 30
- (xi) The sigma notation for the sum $-2 + 4 - 6 + 8$ is:
 a. $\sum_{k=1}^3 (-1)^k (k + 1)$ b. $\sum_{k=1}^5 (-1)^k 2k$
 c. $\sum_{k=1}^4 (-1)^k 2k$ d. $\sum_{k=2}^5 (-1)^k 2k$
- (xii) $\sum_{k=1}^n 5$ is equal to:
 a. n b. $5n$ c. 5 d. 5^n
- (xiii) The general term of the given series $\frac{1}{1 \cdot 3} + \frac{1}{2 \cdot 5} + \frac{1}{3 \cdot 7} + \dots$ is:
 a. $\frac{1}{n(2n+1)}$ b. $\frac{1}{(n+1)(2n-1)}$ c. $\frac{1}{n(n+2)}$ d. $\frac{1}{(n-1)(2n+1)}$
- (xiv) In $\frac{1}{4 \cdot 7} + \frac{1}{7 \cdot 10} + \frac{1}{10 \cdot 13} + \dots$, the n th term is:
 a. $\frac{1}{(3n-1)(3n+1)}$ b. $\frac{1}{(3n-2)(3n+4)}$
 c. $\frac{1}{(3n+1)(3n+4)}$ d. $\frac{1}{(n+2)(n+6)}$
- (xv) The sum $\sum_{r=2}^{\infty} \frac{1}{r^2 - 1}$ represents:
 a. 1 b. $\frac{3}{4}$ c. $\frac{4}{3}$ d. $\frac{1}{4}$
- (xvi) Sum of the series $1 + 3 + 5 + 7 + 9 + 11 + \dots$ is:
 a. n b. n^2 c. $n(n+1)$ d. $(n-1)$
- (xvii) $\sum_{k=1}^{10} 3$ is equal to:
 a. 10 b. 103 c. 300 d. 30

2. The sum of four numbers in A.P. is 24 and their product is 945. Find the numbers.
3. Find four numbers in A.P., whose sum is 6 and sum of whose square is 14.
4. Insert 20 A.Ms. between 2 and 86.
5. Evaluate $3 + 33 + 333 + \dots$ up to n terms.
6. If the product of three numbers in G.P be 216 and their sum be 19, then find the numbers.

7. Insert 4 G.Ms. between 2 and 486.

8. Find n so that $\frac{a^{n+1} + b^{n+1}}{a^n + b^n}$ may be the harmonic means between a and b .

9. Find the H.P., whose 3rd and 14th terms are $\frac{6}{7}$ and $\frac{1}{3}$ respectively.

10. Evaluate the sum:

(i) $\sum_{k=1}^{10} \frac{2^k}{2^{k+1}}$

(ii) $\sum_{k=1}^8 (-1)^{k+1} 3^k$

Sum to n terms of the following (arithmetico-geometric series):

11. $4 + 14 + 30 + 52 + 82 + \dots$

12. $1 + 4 + 10 + 21 + 39 + \dots$

FBISE SOLVED PAST PAPERS

UNIT
05

POLYNOMIALS

After studying this unit, students will be able to:

- State and prove remainder theorem and explain through examples.
- Find remainder (without dividing) when a polynomial is divided by a linear polynomial.
- Define zeros of a polynomial.
- State and prove factor theorem.
- Use factor theorem to factorize a cubic polynomial.
- Apply concepts of remainder and factor theorem to real world problems.



Use of letters to represent an unknown quantity was introduced by “Rene Descartes”, a French Mathematician, in 1637. Today 'x' is used by most of the mathematicians as the standard letter for a single unknown. In fact x-rays were so named because the scientists who discovered them did not know what they were and thus labeled them the 'unknown rays' or x-rays.

Algebra is a branch of Mathematics, which uses letters to represent unknown quantities, numbers and variable quantities. It helps to solve a wide variety of problems. It is basically an extension of Arithmetics.

History a Mystery



Muhammad Bin Musa Al-Khwarizimi was the first Muslim mathematician who introduced Algebra and wrote a book entitled Hisab-Al-Jabr Wal Muqabala in 820 A.D. He is known as 'Father of Algebra'.

5.1 Algebraic Expressions

A statement in which variables or constants or both are connected by arithmetic operations (i.e. +, -, ×, ÷) is called an algebraic expression.

For example,

$$\frac{-5x^2 + 4}{4}, 3(a + b) - 4, 0, -5$$

$$r - \sqrt{2}t, \frac{1}{x}, \sqrt{b^2 - 4ac} \text{ etc.}$$

5.1.1 Kinds of Algebraic Expressions

Algebraic expressions are of three kinds.

1. Polynomial Expressions
2. Rational Expressions
3. Irrational Expressions

1. Polynomial Expressions (Polynomials)

Polynomials are algebraic expressions consisting of one or more terms in which exponents of the variables involved are whole numbers.

For example,

$$0, -2, \frac{3}{4}x + \frac{3}{4}y^2z, -\sqrt{\frac{3}{9}}y^3, \sqrt{2}x^4 - \pi x^2 - \sqrt{10} \text{ etc.}$$

The expressions $x^{-3}, y^2 + \frac{1}{y^2}, \sqrt[3]{y^4}, 2y^{\frac{1}{2}}$ are not polynomials because their exponents are not positive integers (whole numbers).

Types of Polynomials w.r.t. Degree

- Zero polynomial or no degree polynomial:

'0' is called a polynomial of no degree. Also, $0x^3 + 0x$ is a no degree polynomial, because coefficients are always zero in zero polynomial.

Enlighten Yourself



Components of an algebraic expression are:

- Numbers
- Signs of operations (+, -, ×, ÷)
- Variables (a, b, c, ..., x, y, z)
- Grouping symbols —, (), { }, []

Key Facts



The highest exponent of the variable involved in a polynomial is called its degree. If more than one variables are being multiplied in terms of a polynomial, then the degree of that polynomial is the maximum sum of the exponents of the variables involved in the terms.

Constant Polynomial: A polynomial having degree zero is called a constant polynomial.

e.g. 2, -5 , $\frac{1}{2}$, $\sqrt{5}$ are all constant polynomials.

• **Linear Polynomial:** A polynomial having degree one is called a linear polynomial.

e.g., x , $2x - y$, $-7xy^0$ etc.

• **Quadratic Polynomial:** A polynomial having degree two is called a quadratic polynomial.

e.g., $2x^2 + 7$, $ax + 2xy + 3$, $-\frac{3}{4}xyz^0$ etc.

• **Cubic Polynomial:** A polynomial having degree three is called a cubic polynomial.

e.g. $9x^3 - 7x + 5$, $-9xzy$, $3x^2y - \frac{3}{4}z$ etc.

All other polynomials have no specific name w.r.t. degree but simply, we call them polynomials of degree four, degree five and so on.

2. Rational Expression

An algebraic expression of the form $\frac{P(x)}{Q(x)}$, where $P(x)$ and $Q(x)$ are polynomials and $Q(x) \neq 0$ (i.e.

it is not a zero polynomial) is called a Rational Expression.

For example, $1\frac{1}{2}$, $\frac{3}{4x^2}$, $\frac{2x-1}{x^2+3}$, $\frac{2x+4}{x^2+5x+6}$, $\frac{x^2+x}{x^3+x}$, 5 etc.

3. Irrational Expression

An algebraic expression which cannot be expressed in the form $\frac{P(x)}{Q(x)}$, where $P(x)$ and $Q(x)$ are

polynomials but Q is not a zero polynomial is called an irrational expression.

For example: $\frac{x}{\sqrt{y}}$, $x^2y - 7$, $\sqrt{x} - \frac{1}{\sqrt{y}}$, $\sqrt{x^2 + y^2}$, $24x^{\frac{3}{2}}y^{-2} + \frac{9}{y^2} - 7$ etc.

5.2 Remainder Theorem and Factor Theorem

If we have two polynomials

$p(x) = x^3 - 6x^2 + 14x - 8$ and $d(x) = x - 2$, then dividing $p(x)$ by $d(x)$, we can find the quotient and remainder as follows.

$$\begin{array}{r}
 x^2 - 4x + 6 \leftarrow \text{Quotient} \\
 \text{Divisor} \rightarrow x - 2 \overline{) x^3 - 6x^2 + 14x - 8} \leftarrow \text{Dividend} \\
 \underline{+ x^3 - 2x^2} \\
 -4x^2 + 14x \\
 \underline{-4x^2 + 8x} \\
 6x - 8 \\
 \underline{+ 6x - 12} \\
 4 \leftarrow \text{remainder}
 \end{array}$$

So, quotient = $x^2 - 4x + 6$ and remainder = 4
 Similarly, here

$$\begin{aligned} \text{quotient} \times \text{divisor} + \text{remainder} &= (x^2 - 4x + 6)(x - 2) + 4 \\ &= x(x^2 - 4x + 6) - 2(x^2 - 4x + 6) + 4 \\ &= x^3 - 4x^2 + 6x - 2x^2 + 8x - 12 + 4 \\ &= x^3 - 6x^2 + 14x - 8 \\ &= \text{dividend} \end{aligned}$$

Here, $(x - 2)$ is the divisor of $x^3 - 6x^2 + 14x - 8$.

If we put $x = 2$ in the dividend, we have,

$$\begin{aligned} p(2) &= (2)^3 - 6(2)^2 + 14(2) - 8 \\ &= 8 - 6(4) + 28 - 8 \\ &= 8 - 24 + 28 - 8 \\ &= 36 - 32 \\ &= 4 \leftarrow \text{remainder} \end{aligned}$$

Key Facts



When you put $x = 2$ in $p(x)$ then the factor $x - 2$ is just zero.

Hence, $p(2)$ gives us same remainder which we have got by long division.

i.e. $p(2) = \text{remainder}$

\therefore We can deduce that, if a polynomial $x^3 - 6x^2 + 14x - 8$ is divided by a polynomial $x - 2$, the remainder is 4 and the value of dividend at $x = 2$ also equals remainder.

Conclusion: If $p(x) = x^3 - 6x^2 + 14x - 8 \leftarrow \text{dividend}$

$$d(x) = x - 2 \leftarrow \text{divisor}$$

then, remainder = $p(2) = 4$

5.2.1 Remainder Theorem

Statement: If a polynomial $p(x)$ is divided by $x - c$ (where c is a constant), then the remainder is $p(c)$.

Proof: We know that:

$$\text{dividend} = \text{divisor} \times \text{quotient} + \text{remainder.}$$

Let $q(x)$ be the quotient and r be the remainder when $p(x)$ is divided by $(x - c)$, then

$$p(x) = (x - c)q(x) + r \dots\dots (i)$$

Substituting $x = c$ in result (i), we have

$$\begin{aligned} p(c) &= (c - c)q(c) + r \\ &= 0 + r = r, \text{ which is the remainder.} \end{aligned}$$

Hence, $p(c)$ is the remainder when $p(x)$ is divided by $x - c$.

Example: Find remainder if $x^3 - 5x^2 + 7x - 6$ is divided by $x - 3$.

Solution: Let $p(x) = x^3 - 5x^2 + 7x - 6$

$$d(x) = x - 3$$

By using the Remainder Theorem,

$$p(x) = x^3 - 5x^2 + 7x - 6$$

$$\text{Remainder} = p(3)$$

Key Facts



Remainder theorem provides us a helpful tool for finding remainder instead of doing long division.

$$\begin{aligned}
 &= (3)^3 - 5(3)^2 + 7(3) - 6 \\
 &= 27 - 5(9) + 21 - 6 \\
 &= 27 - 45 + 21 - 6 \\
 &= 48 - 51 = -3
 \end{aligned}$$

Example: Find the value of p , when $3x^4 - 4px^2 + 5x - p$ is divided by $x + 2$ and the remainder is 4.

Solution: Let $f(x) = 3x^4 - 4px^2 + 5x - p$; $d(x) = x + 2$

By using remainder theorem,

$$\text{Remainder} = f(-2) = 3(-2)^4 - 4p(-2)^2 + 5(-2) - p$$

$$4 = 3(16) - 4p(4) - 10 - p$$

$$4 = 48 - 16p - 10 - p$$

$$4 = 38 - 17p$$

$$38 - 4 = 17p$$

$$34 = 17p$$

$$p = \frac{34}{17} = 2$$

Hence, the value of p is 2.



- Pay Heed**
- Degree of dividend is always greater than or equal to the degree of divisor
 - Degree of remainder is always less than the degree of divisor.

5.2.2 Zeros of a Polynomial

Consider an equation, $2x + 5 = 9$

$$2x + 5 = 9$$

$$2x + 5 - 5 = 9 - 5$$

$$2x = 4$$

$$\text{or } x = 2$$

Here '2' is called the root of $2x + 5 = 9$, as it satisfies the equation.

Hence, the roots of a polynomial $p(x)$ means the values of x that satisfies $p(x) = 0$. These roots are called 'zeros of the polynomial'.

The values of x which satisfy $p(x) = 0$ are called 'Zeros of the Polynomial $p(x)$ '.

For example 5 and -5 are the zeros of the polynomial $p(x) = x^2 - 25$, because

$$\begin{aligned}
 p(5) &= (5)^2 - 25 \\
 &= 25 - 25 = 0
 \end{aligned}$$

$$\begin{aligned}
 \text{and } p(-5) &= (-5)^2 - 25 \\
 &= 25 - 25 = 0
 \end{aligned}$$

Basically, when we are finding zeros of a polynomial, we are looking for those values of x which cause the values of polynomial equal to zero.

Example:

Is -3 a zero of polynomial $p(x) = 2x^4 + 7x^3 - 4x^2 - 27x - 18$?

Solution: '-3' will be a zero of $p(x) = 2x^4 + 7x^3 - 4x^2 - 27x - 18$,

$$\text{If } p(-3) = 0$$

$$\begin{aligned}
 \text{So } p(-3) &= 2(-3)^4 + 7(-3)^3 - 4(-3)^2 - 27(-3) - 18 \\
 &= 2(81) + 7(-27) - 4(9) - 27(-3) - 18 \\
 &= 162 - 189 - 36 + 81 - 18 \\
 &= 243 - 243 = 0
 \end{aligned}$$

Hence, '-3' is the zero of $p(x)$.



Memory Plus
The zeros of $p(x) = x^2 - 9$ are the same as the solution to the equation $x^2 - 9 = 0$.

Example: If zeros of a polynomial are 0, 6, -1, find the polynomial.

Solution: Let required polynomial be $g(x)$. Then setting $x = 0, 6, -1$, we have

$$\begin{aligned} g(x) &= (x - 0)(x - 6)(x + 1) \\ &= x(x^2 - 6x + x - 6) \\ &= x^3 - 5x^2 - 6x \end{aligned}$$

Example: If one zero of $g(x) = 2x^3 + x^2 - 2x - 1$ is $-\frac{1}{2}$, find its other zeros.

Solution: If one zero of the given polynomial is $-\frac{1}{2}$, then its other zeros can be found by

factorizing it. Setting $x = -\frac{1}{2}$, so that $2x + 1$ is the factor of $g(x)$.

First divide $g(x)$ by $2x + 1$ for getting its quadratic factor.

$$\begin{array}{r} x^2 - 1 \\ 2x + 1 \overline{) 2x^3 + x^2 - 2x - 1} \\ \underline{\pm 2x^3 \pm x^2} \\ - 2x - 1 \\ \underline{- 2x - 1} \\ + + \\ 0 \end{array}$$

So, $2x^3 + x^2 - 2x - 1 = (2x + 1)(x^2 - 1)$
 $= (2x + 1)(x - 1)(x + 1)$ ← factorizing

Hence, its other zeros are 1 and -1. ← setting $x - 1 = 0$ and $x + 1 = 0$
 i.e. $x = 1$ and $x = -1$

5.3 Factor Theorem

Factor Theorem is a result of Remainder Theorem and is based on the same reasoning.

Statement: A polynomial $p(x)$ has a factor $x - c$, if and only if $p(c) = 0$.

Proof: Let $q(x)$ be the quotient and r be the remainder when $p(x)$ is divided by $(x - c)$ then, $p(x) = (x - c)q(x) + r$ (i)

If $x - c$ is a factor of $p(x)$, then $r = 0$.

Now by Remainder Theorem, $r = p(c)$

∴ remainder = $p(c) = 0$

Conversely, if $p(c) = 0$, that means, remainder = 0

Therefore, result (i) reduces to

$$p(x) = (x - c)q(x)$$

∴ $(x - c)$ is a factor of $p(x)$.

Hence, $(x - c)$ will be the factor of $p(x)$ if and only if $p(c) = 0$.

Key Facts



Every factor is a divisor but every divisor is not a factor of polynomial.
 Factor of a polynomial divides it completely.

Example: Show that $y - 1$ is a factor of $y^4 - 24y^2 - 13y + 36$.

Solution: Let $f(y) = y^4 - 24y^2 - 13y + 36$ (i)

By Factor Theorem, $y - 1$ will be a factor of $f(y)$, if $f(1) = 0$.

So, first we find $f(1)$.

$$\begin{aligned} f(1) &= (1)^4 - 24(1)^2 - 13(1) + 36 \quad \longrightarrow \text{substituting } y = 1 \text{ in} \\ f(1) &= 1 - 24 - 13 + 36 \\ &= 37 - 37 \\ &= 0 \end{aligned}$$

i.e. remainder = 0

Hence, $y - 1$ is a factor of $y^4 - 24y^2 - 13y + 36$.

Example: Determine the value of k for which $x + 3$ is a factor of $(x + 2)^5 + (3x + k)$.

Solution: Let $f(x) = (x + 2)^5 + (3x + k)$, $d(x) = x + 3$

As $x + 3$ is a factor of $f(x)$, so by Factor Theorem,

$$\begin{aligned} \text{i.e.} \quad f(-3) &= 0 \\ (-3 + 2)^5 + [3(-3) + k] &= 0 \\ (-1)^5 + (-9 + k) &= 0 \\ -1 - 9 + k &= 0 \\ -10 + k &= 0 \quad \text{or } k = 10 \end{aligned}$$

Exercise 5.1

- Find the remainder of the following by using 'Remainder Theorem' when
 - $2x^3 + 3x^2 - 4x + 1$ is divided by $x + 2$.
 - $x^4 + 2x^3 - x^2 + 2x + 3$ is divided by $x - 2$.
- Show that $x - 3$ is a factor of $x^3 - 2x^2 - 5x + 6$.
- Decide whether $x - 3$ is a factor of $x^3 - 2x^2 - 5x + 1$ or not.
- If $4y^3 - 4y^2 + 10 + 2y$ is completely divisible by any of its factor such that the quotient is $4y^2 - 8y + 10$, then find other factor.
- Find the value of 'q' if $x^3 + qx^2 - 7x + 6$ is exactly divisible by $(x + 1)$.
- Find the value of 'm' in the polynomial $2x^3 + 3x^2 - 3x - m$ which when divided by $x - 2$ gives the remainder of 16.
- Check whether 1 and -2 are the zeros of $x^3 - 7x + 6$.
- Find zeros of the polynomial $2x^3 + 3x^2 - 11x - 6$.
- Express $f(x) = x^3 - x^2 - 14x + 8$ in the form $f(x) = (x - a)q(x) + r$, where $a = 4$.
- A rectangular room has a volume of $(x^3 + 11x^2 + 34x + 24)$ cubic feet. The height of the room is $(x + 1)$ feet. Find the area of its floor.
(Hint: Volume of room = area of floor \times height.)

5.4 Factorization of a Cubic Polynomial

By using Factor Theorem together with some intelligent guessing, we can factorize polynomials of higher degree. Consider a cubic polynomial,

$$f(x) = x^3 - 2x^2 - 5x + 6$$

The process of factorizing above polynomial is explained as under.

Step-I: Obtain one factor by hit and trial.

First try, $x - 1$.

Here, $x - 1$ will be the factor of $f(x)$ if $f(1) = 0$ \longrightarrow by Factor Theorem

$$\begin{aligned} f(1) &= (1)^3 - 2(1)^2 - 5(1) + 6 \\ &= 1 - 2 - 5 + 6 \\ &= 7 - 7 = 0 \end{aligned}$$

Hence, $(x - 1)$ is a factor of $f(x)$.

Step-II: Divide $x^3 - 2x^2 - 5x + 6$ by $x - 1$ to find its other factor $q(x)$.

$$\begin{array}{r} x^2 - x - 6 \\ x-1 \overline{) x^3 - 2x^2 - 5x + 6} \\ \underline{+ x^3 - x^2} \\ -x^2 - 5x + 6 \\ \underline{+ x^2 + x} \\ -6x + 6 \\ \underline{+ 6x + 6} \\ 0 \end{array}$$

So, $(x^3 - 2x^2 - 5x + 6) = (x - 1)(x^2 - x - 6)$.

Step-III: Factorize quadratic factor (if possible) for other linear factors.

$$\begin{aligned} & \downarrow \\ & x^3 - 2x^2 - 5x + 6 \\ &= (x - 1)(x^2 - x - 6) \\ &= (x - 1)(x^2 - 3x + 2x - 6) \\ &= (x - 1)[x(x - 3) + 2(x - 3)] & (-1)(+2)(-3) = +6 \\ &= (x - 1)(x - 3)(x + 2) \end{aligned}$$

Hence,

$$x^3 - 2x^2 - 5x + 6 = (x - 1)(x - 3)(x + 2)$$



Example: If two linear factors of the polynomial $2y^3 + y^2 - 8y - 4$ are $(2y + 1)$ and $(y - 2)$, find its third factor. unknown factor

Solution: $2y^3 + y^2 - 8y - 4 = (2y + 1)(y - 2)(?)$
 $2y^3 + y^2 - 8y - 4 = (2y^2 + y - 4y - 2)(?)$
 $2y^3 + y^2 - 8y - 4 = (2y^2 - 3y - 2)(?)$
 $\frac{2y^3 + y^2 - 8y - 4}{2y^2 - 3y - 2} = (?)$

$$\begin{array}{r}
 \overline{) 2y^3 + y^2 - 8y - 4} \\
 + 2y^3 - 3y^2 - 2y \\
 \underline{- + +} \\
 4y^2 - 6y - 4 \\
 + 4y^2 - 6y - 4 \\
 \underline{- + +} \\
 0
 \end{array}$$

Hence, missing factor is $(y + 2)$.

$\therefore 2y^3 + y^2 - 8y - 4 = (2y + 1)(y - 2)(y + 2)$

Example: Factorize $x^3 - 5x - 2$ by factor theorem.

Solution: Let $f(x) = x^3 - 5x - 2$

Step-I For $x = -2$, $f(-2) = (-2)^3 - 5(-2) - 2$
 $= -8 + 10 - 2 = 0$

Hence, $x + 2$ is one of the factors of $x^3 - 5x - 2$.

Step-II: Now, we divide $x^3 - 5x - 2$ by $(x + 2)$.

So, $x^3 - 5x - 2 = (x + 2)(x^2 - 2x - 1)$

Hence, $x^3 - 5x - 2 = (x + 2)(x^2 - 2x - 1)$

$$\begin{array}{r}
 \overline{) x^3 - 5x - 2} \\
 \pm x^3 \pm 2x^2 \\
 \underline{- 5x - 2 - 2x^2} \\
 - 4x - 2x^2 \\
 \underline{+ +} \\
 - x - 2 \\
 \underline{- x - 2} \\
 \underline{+ +} \\
 0
 \end{array}$$

Key Facts



By inspecting, if $f(x)$ is of degree three, we would expect it to have three linear factors at most, so that $f(x) = (x + a)(x + b)(x + c)$, where a , b and c can be positive or negative numbers. Also, by multiplying the last term of each factor, $a b c$ numerically equals the last term of the polynomial.

Exercise 5.2

Factorize the following by using factor theorem.

1. $y^3 - 7y - 6$ 2. $2x^3 - x^2 - 2x + 1$ 3. $2x^3 + 5x^2 - 9x - 18$
4. $3x^3 - 5x^2 - 36$ 5. $t^3 + t^2 + 3t - 5$
6. If $(x - 2)$ is one of the factor of $2x^3 - 15x^2 + 16x + 12$, find its other factors.
7. Factorize $2x^3 - 15x^2 + 27x - 10$ if $\frac{1}{2}$ is one of its zero.
8. If $h(x) = 4x^3 + 4x^2 + 73x + 36$ and $h\left(\frac{-1}{2}\right) = 0$, then factorize $h(x)$.

5.5 Applications of Remainder Theorem

If you give 10 pencils to five students out of 11, each will get 2 pencils. Only one pencil will remain with you and this leftover 1 pencil is called the remainder. 11 is the dividend, 5 is the divisor, 2 is the quotient and 1 is the remainder.

A remainder theorem formula is a powerful tool that can be used to solve a variety of mathematical problems. A remainder formula is used to differentiate the polynomials.

Suppose Nasir hits a high fast ball straight up over home plate. The function that describes the height of the ball after t seconds is

$$h(t) = -16t^2 + 80t + 5$$

The roots of the function tell us that at what times the ball is theoretically in the ground. When $t = 0$, the height of the ball is 5 feet. This is the point at which he hits the ball.

Suppose we find the height of the ball after 4 seconds.

$$h(t) = -16t^2 + 80t + 5$$

$$h(4) = -16(4)^2 + 80(4) + 5 \quad \text{replace } t \text{ with } 4.$$

$$h(4) = 69$$

After 4 seconds, the height of the ball is 69 feet.

Notice that the value of $h(4)$ is the same as the remainder when polynomial is divided by $t - 4$.

Example: The volume of a rectangular solid is 72 cubic units. The width is twice the height and the length is 7 units more than the height. Find the dimensions of the solid.

Let x be the height of the solid.

$$\text{volume} = (2x)(x + 7)(x)$$

$$72 = 2x^3 + 14x^2$$

$$x^3 + 7x^2 - 36 = 0$$

Trace the possible zeros.

The zero is 2.

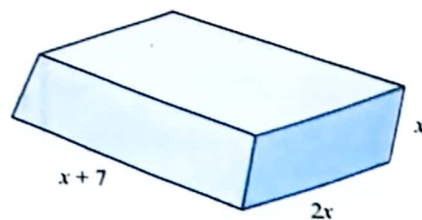
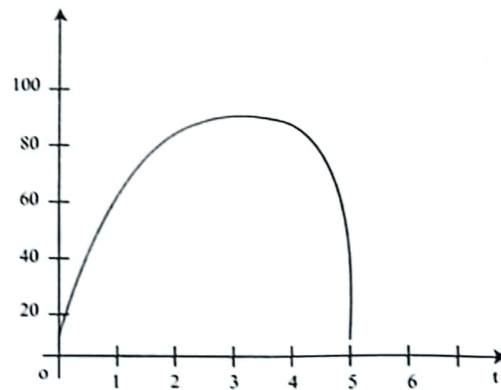

$$(2)^3 + 7(2)^2 - 36 = 0$$

$$0 = 0$$

So,

$$\text{height} = x = 2$$

$$\text{width} = 2x = 4$$

$$\text{length} = x + 7 = 9$$

Exercise 5.3

- The volume of a drinking water bottle is 120 cubic centimeters. The bottle is 7 centimeters longer than it is tall. Find the dimensions of the bottle.
- In the cricket match season, the number of tickets sold during the match can be modeled by $t(x) = x^3 - 12x^2 + 48x + 74$, where x is the number of games played. Find the number of tickets sold during the twelfth game of the cricket season.
- A rectangular solid has a volume of 14 cubic units. The width is twice the height and the length is 2 units more than the width. Find the dimensions of the solid.
- The volume of a rectangular solid is 2475 cubic units. The length of the box is three units more than twice the width of the box. The height is 2 units less than width. Find the dimensions of the box.
- The area of rectangle ACED is represented by $6x^2 + 38x + 56$. Its width is represented by $2x + 8$. Point B is the midpoint of AC. A BFG is a square. Find the length of rectangle ACED and the area of square ABFG.
- The volume of the box is $y^3 - 2y^2 - y + 2$. If the length of one side is $y - 2$, find the length of the other two sides.

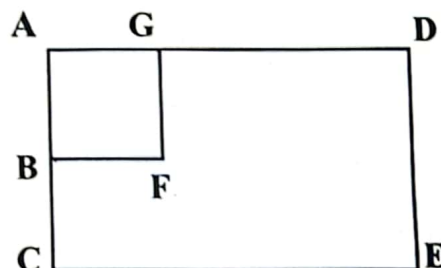

I have Learnt

- Stating and proving remainder theorem and explaining through examples.
- Finding remainder (without dividing) when a polynomial is divided by a linear polynomial.
- Defining zeros of a polynomial.
- Stating and proving factor theorem.
- Using factor theorem to factorize a cubic polynomial.
- Applying concepts of remainder and factor theorem to real world problems.

Miscellaneous Exercise

1. Encircle the correct option in the following.

(i) Factors of $-2 - x + x^2$ are:

- (a) $(x-2)(x-1)$ (b) $(x+1)(x+2)$ (c) $(x+2)(x-1)$ (d) $(x+1)(x-2)$

(ii) Divide $9y^2 + 9y - 10$ by $3y - 2$, then remainder is:

- (a) 0 (b) 1 (c) 2 (d) 3

(iii) $\frac{x^2 - x - 9}{x - 3} = x + 2 + \frac{?}{x - 3}$

- (a) -27 (b) -3 (c) $\frac{3}{x-3} + x + 2$ (d) 3

(iv) If $3x^3 - 2x^2 + 5$ is divided by $x + 1$, then $x + 1$ will be its:

- (a) divisor as well as factor (b) dividend
(c) quotient (d) remainder

(v) If 2 is a zero of the polynomial $x^3 + 5x^2 - 4x + k$, then the value of k will be:

- (a) -4 (b) -20 (c) 20 (d) 0

(vi) If $x - b$ is the factor of $q(x)$, then $q(b)$ is:

- (a) factor (b) divisor (c) remainder (d) dividend

(vii) If the expression $2x^3 + 3px^2 - 4x$ has a remainder of 4 when divided by $x + 2$, then $p =$

- (a) -2 (b) 1 (c) -1 (d) 0

(viii) If $f(x)$ is divided by $x - 2$, then remainder is 12. What is $f(2)$?

- (a) -12 (b) $f(-2)$ (c) 12 (d) zero

2. $(64y^3 - 8) \div (4y - 2)$ 3. $(125y^3 - 8) \div (5y - 2)$

4. Is $3y - 2$ a factor of $6y^3 - y^2 - 5y + 2$?

5. If zeros of a polynomial are $4, \frac{3}{5}, -2$, find the polynomial.

6. Find the value of 'k' so that the remainder upon dividing $(x^2 + 8x + k)$ by $(x - 4)$ is zero.

7. Suppose that the quotient upon dividing one polynomial by another is

$$3x^2 - x + 32 - \frac{121}{x + 4}$$

What is the dividend?

8. If two linear factors of the polynomial $y^3 + 6y^2 - y - 30$ are $(y - 2)$ and $(y + 3)$, find its third factor.

UNIT
06

PERMUTATION AND COMBINATION

After studying this unit, students will be able to:

- Know Kramp's factorial notation to express the product of first n natural numbers by $n!$.
- Recognize the fundamental principle of counting and illustrate this principle using tree diagram.
- Define the permutation of n different objects taken r at a time and proof of formula of permutation.
- Find out the arrangement of different objects including around a circle.
- Define the combination of n different objects taken r at a time.
- Prove formula of combination and solve problems involving combination.
- Apply the above formulas for permutation and combination to solve the real world word problems.

The history of counting is as old as the humanity is. Counting is a basic tool. How to count correctly and quickly is very important in our daily life. For this purpose, we develop the techniques for computing number of elements in sets without listing them. To determine a general rule, we consider a coin and a dice. A coin has two outcomes that is head and tail while a die has six outcomes 1, 2, 3, 4, 5 and 6. Then the outcomes of tossing a coin and rolling a die are $(H, 1), (H, 2), (H, 3), (H, 4), (H, 5), (H, 6), (T, 1), (T, 2), (T, 3), (T, 4), (T, 5), (T, 6)$.

These outcomes are 12 in number. We can also find this number 12 without listing all outcomes. We know that a coin has two outcomes while a die has six outcomes. So, the total outcomes are the product of values of two things that is $2 \times 6 = 12$.



6.1 Rule of Product

If A can happen in m ways and B can happen in n ways then the pair (A, B) can happen in $m \times n$ or mn ways. If we have three objects A, B and C which can happen in m , n and p ways respectively. Then the triplet (A, B, C) can be written in $m \times n \times p$ or mnp ways. In this unit, we will develop formulae and techniques for counting the number of objects. Then these formulae will be used to calculate the number of arrangements of the objects.

6.2 Factorial Notation

Factorial notation was introduced by French mathematician Christian Kramp in 1808. Factorial of an integer n is denoted by

$$n! = 1 \times 2 \times 3 \dots (n-1)n$$

and is defined as the product of all the positive integers from n down to 1.

Factorials for First 6 Numbers

$$\begin{aligned} 0! &= 1, 1! = 1 \\ 2! &= 2 \times 1 = 2, 3! = 3 \times 2 \times 1 = 6 \\ 4! &= 4 \times 3 \times 2 \times 1 = 24 \\ 5! &= 5 \times 4 \times 3 \times 2 \times 1 = 120 \\ 6! &= 6 \times 5 \times 4 \times 3 \times 2 \times 1 = 720 \end{aligned}$$

Key Fact

All the scientific calculators have a factorial key commonly locate on the top of x^{-1} have sign $x!$ is used with shift button. For example, $4! = 24$.



Point to be Noted

$$2! \times 4! = (2 \times 1)(4 \times 3 \times 2 \times 1) = 48$$

$$(2 \times 4)! = 8! = 40320$$

In general; $(m \times n)! \neq m! \times n!$
 $(m + n)! \neq m! + n!$

Example: Simplify the following.

(i) $\frac{8!}{5!}$ (ii) $\frac{1}{4! \times 3!} + \frac{7}{5! \times 2!}$ (iii) $\frac{(n+1)!}{(n-2)!}$

Solution:

(i) $\frac{8!}{5!} = \frac{8 \cdot 7 \cdot 6 \cdot 5!}{5!} = 8 \cdot 7 \cdot 6 = 336$

(ii) $\frac{1}{4! \times 3!} + \frac{7}{5! \times 2!} = \frac{5}{5 \cdot 4! \times 3!} + \frac{7 \times 3}{5! \times 3 \cdot 2!}$
 $= \frac{5}{5! \times 3!} + \frac{21}{5! \times 3!} = \frac{5+21}{120 \times 6} = \frac{26}{720} = \frac{13}{360}$

(iii) $\frac{(n+1)!}{(n-2)!} = \frac{(n+1)n(n-1)(n-2)!}{(n-2)!} = (n+1)n(n-1) = n^3 - n$

Example: Write the following in factorial form.

(i) $\frac{13 \cdot 12 \cdot 11 \cdot 9 \cdot 5}{6 \cdot 5 \cdot 4}$ (ii) $\frac{(n-4)(n-3)(n-1)}{n(n-1)}$

Solution:

(i) $\frac{13 \cdot 12 \cdot 11 \cdot 9}{6 \cdot 5 \cdot 4} = \frac{13 \cdot 12 \cdot 11 \cdot 10! \cdot 9 \cdot 8!}{6 \cdot 5 \cdot 4 \cdot 3!} \times \frac{3!}{10! \cdot 8!} = \frac{13! \cdot 9! \cdot 3!}{10! \cdot 8! \cdot 6!}$

(ii) $\frac{(n-4)(n-3)(n-2)}{n(n-1)} = \frac{(n-2)(n-3)(n-4)(n-5)!}{n(n-1)(n-2)!} \times \frac{(n-2)!}{(n-5)!}$
 $= \frac{(n-2)!(n-2)!}{n!(n-5)!} = \frac{[(n-2)!]^2}{n!(n-5)!}$

Exercise 6.1

1. Evaluate the following:

(i) $10!$ (ii) $\frac{12!}{7!3!2!}$ (iii) $\frac{4!-2!}{3!+5!}$ (iv) $\frac{(n-1)!}{(n-2)!}$ (v) $\frac{8!}{(6!)^2}$

2. Write the following in factorial form:

(i) $14.13.12.11$ (ii) $1.3.5.7.9$ (iii) $n(n^2 - 1)$ (iv) $\frac{(n-3)(n-2)(n-1)}{n(n-4)}$

3. Prove the following:

(i) $\frac{1}{5!} + \frac{3}{6!} + \frac{1}{7!} = \frac{4}{315}$ (ii) $\frac{(n-1)!}{(n-3)!} = n^2 - 3n + 2$

4. Show that:

(i) $\frac{(2n)!}{n!} = 2^n(1.3.5 \dots (2n-1))$ (ii) $\frac{(2n-1)!}{n!} = 2^{n-1}(1.3.5 \dots (2n-1))$

5. Find the values of n in the following.

(i) $\frac{n}{(n-4)!} = \frac{3.3!}{(n-3)!}$ (ii) $\frac{n!}{(n-4)!} : \frac{(n-1)!}{(n-3)!} = 36 : 2$

6. Prove the following for $n \in \mathbb{N}$,

(i) $(2n)! = 2^n(n!)[1.3.5 \dots (2n-1)]$
 (ii) $(n+1)[n!n + (n-1)!(2n-1) + (n-2)!(n-1)!] = (n+2)!$
 (iii) $\frac{n!}{r!(n-r)!} + \frac{n!}{(r-1)!(n-r+1)!} = \frac{(n+1)!}{r!(n-r+1)!}$
 (iv) $\frac{n!}{r!} = n(n-1)(n-2) \dots (r+1)$
 (v) $(n-r+1) \cdot \frac{n!}{(n-r+1)!} = \frac{n!}{(n-r)!}$
 (vi) $33!$ is divisible by 2^{15}
 (vii) $\frac{2n!}{[(n-1)!]^2} = \frac{n(n+1)(n+2)\dots(2n-1)(2n)}{(n-1)!}$
 (viii) $(n! + 1)$ is not divisible by any natural number between 2 and n .
 (ix) $(n!)^2 \leq n^n \cdot n! < (2n)!$

7. Find n , if

(i) $\frac{n!}{(n-2)!} = 930, n \geq 2$ (ii) $\frac{n!}{(n-5)!} = 20 \cdot \frac{n!}{(n-3)!}, n \geq 5$
 (iii) $(n+2)! = 60 \cdot (n-1)!$ (iv) $(n+2)! = 132 \cdot n!$
 (v) $(n+2)! = 56 \cdot n!$ (vi) $\frac{1}{9!} + \frac{1}{10!} = \frac{n}{11!}$
 (vii) $n! = 990 \cdot (n-3)!$ (viii) $(n+1)! = 6 \cdot (n-1)!$
 (ix) $\frac{(n+2)!}{(2n-1)!} = \frac{(n+3)!}{(2n+1)!} \cdot \frac{72}{7}$ (x) $\frac{(2n)!}{4!(2n-3)!} \cdot \frac{4!(n-4)!}{n!} = 52$
 (xi) $\frac{1}{2(n-2)!} : \frac{1}{4!(n-4)!} = 2, n \geq 4$

6.3 Permutation

The number of ways in which r objects out of n objects $0 \leq r \leq n$ can be arranged in a definite order is called permutation.

Example: If a vehicle number plate consists of four digits; then the different number plates consisting of distinct digits from 1, 2, 3, 4, 5, 6 can be counted as follows.



For the first digit, we have 6 choices of digits 1, 2, 3, 4, 5, 6. For the second digit, we have 5-choices; because the selected digit cannot be selected again. Similarly, for the third digit, there are 4-choices and for the fourth digit, we are left with 3-choices.

So, the total number of plates = $6 \times 5 \times 4 \times 3 = 360$

Example: Suppose a student has four different subject's books and wish to arrange them on a shelf. In how many ways he can arrange the books, can be counted as follows.

For the first place he has 4 choices, for the second place he has 3 choices, for the third place he has 2 choices and for the fourth place he has 1 choice.

Hence total number of arrangements are = $4 \times 3 \times 2 \times 1 = 24 = 4!$

So, we can conclude that if we have n distinct objects then total number of arrangements are $n!$.

6.3.1. Permutation of n Distinct Objects Taken r at a Time ($0 \leq r \leq n$)

Here we are going to generalize the above discussed counting process.

Let we have n number of distinct objects and we want to arrange r of them in some order.

We denote such arrangement by ${}^n P_r$ and read it as n -permutation- r .

For the first object, we have n choices.

For the second object, we have $n - 1$ choices.

For the third object, we have $n - 2$ choices.

For the third object, we have $n - 2$ choices, and so on.

For the r^{th} object, we have $[n - (r - 1)] = (n - r + 1)$.

We write ${}^n P_r$ in factorial form as:

$$\begin{aligned}
 {}^n P_r &= n(n-1)(n-2) \dots (n-r+1) \times \frac{(n-r)(n-r-1)(n-r-2) \dots 3.2.1}{(n-r)(n-r-1)(n-r-2) \dots 3.2.1} \\
 &= \frac{n(n-1)(n-2) \dots (n-r+1)(n-r)(n-r-1)(n-r-2) \dots 3.2.1}{(n-r)(n-r-1)(n-r-2) \dots 3.2.1} = \frac{n!}{(n-r)!}
 \end{aligned}$$

$${}^n P_r = \frac{n!}{(n-r)!}$$

Deductions

(i) If $r = n$; then

$$\begin{aligned} {}^n P_n &= n(n-1)(n-2) \dots (n-n+1) \\ &= n(n-1)(n-2) \dots 1 = n! \\ {}^n P_n &= \frac{n!}{(n-n)!} = \frac{n!}{0!} \end{aligned}$$

(ii) Since, ${}^n P_n = n!$

Therefore, $n! = \frac{n!}{0!} \Rightarrow 0! = \frac{n!}{n!} = 1$

$0! = 1$

Example: In how many ways can 6 peoples out of 8 can be seated in a row?

Solution: Total number of people = $n = 8$

People to be seated = $r = 6$

$$\begin{aligned} \text{Total number of ways} &= {}^n P_r = {}^8 P_6 = \frac{8!}{(8-6)!} = \frac{8!}{2!} \\ &= \frac{8 \cdot 7 \cdot 6 \cdot 5 \cdot 4 \cdot 3 \cdot 2!}{2!} = 20160 \end{aligned}$$

6.3.2. Permutation of n Objects When Some of Them are Alike (not Distinct)

Let we have total 'n' number of objects which are all not distinct. Suppose that there are n_1 objects in 1st similar objects category, n_2 objects in the 2nd similar objects category, and similarly, n_k objects in the kth similar objects category.

So, $n = n_1 + n_2 + n_3 + \dots + n_k$.

Let X be the total number of permutations in this situation. If we consider all similar objects as distinct objects in all the categories, then number of permutations for 1st category are $n_1!$, for 2nd category $n_2!$ and for the kth category $n_k!$.

∴ We have $X \cdot n_1! \cdot n_2! \dots n_k!$ number of permutations.

But total number of permutations are $n!$, therefore

$$\begin{aligned} X \cdot n_1! \cdot n_2! \dots n_k! &= n! \\ \Rightarrow X &= \frac{n!}{n_1! \cdot n_2! \dots n_k!} \\ {}^n P_n &= \frac{n!}{n_1! \cdot n_2! \dots n_k!} \end{aligned}$$

Example: How many different arrangements of the letter used in the word EVENING can be made by using all the letters?

Solution: The total number of letters in the word 'EVENING' = 7

Here, E is repeated 2 times, N is repeated 2 times

Thus, number of permutations are ${}^7 P_7 = \frac{7!}{2! \cdot 2!} = \frac{7 \cdot 6 \cdot 5 \cdot 4 \cdot 3 \cdot 2!}{2! \cdot 2!} = 1260$

6.3.3. Circular Permutation

Some times we have to find the number of permutations while arranging the objects about the circle.

Observe these four arrangements; $abcd, bcda, cdab, dabc$

All are distinct along a line but all are same along a circle. Since

the position of each object with reference to other is same,

$$\therefore \text{Number of arrangements} = \frac{4!}{4} = \frac{4 \cdot 3 \cdot 2 \cdot 1}{4} = 6$$

So, if we have n number of objects which are all to be arranged in a circle, then

$$\text{Number of ways} = \frac{n!}{n} = \frac{n(n-1)!}{n} = (n-1)!$$

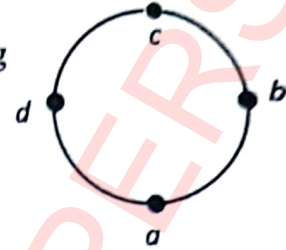

Check Point



In how many different ways can the letters of the word 'OPTICAL' be arranged so that the vowels always come together?

Example: In how many ways 8 people can sit around a circular table for dinner.

Solution:

$$\text{Total number of people} = n = 8$$

$$\text{Number of permutations} = (8-1)! = 7! = 5040 \text{ ways}$$

Example: There are 5 men and 5 women in a party. Find the number of ways in which they can be seated at a round table if:

- (i) anyone can occupy any seat, (ii) men and women have alternate seats.

Solution:

- (i) Total number of persons = $5 + 5 = 10$

Since there is no restriction, so they can sit in $(10-1)! = 9!$ ways.

- (ii) We can start either with men or women. If we start with men then they can be seated in $(5-1)!$ ways

So, the total number of ways that 5 men and 5 women be seated at round table such that they occupy alternative seats = $4! \times 5! = 24 \times 120 = 2880$

Now we consider the case in which the objects are arranged in a circular manner but we can flip or turned over them.

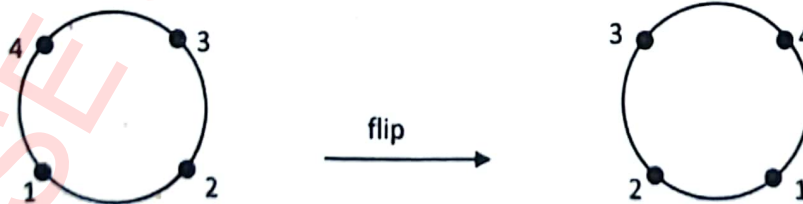

The arrangements which were anticlockwise are now in clockwise direction after flipping but are same. So, number of arrangements are $\frac{(4-1)!}{2} = \frac{3!}{2} = \frac{6}{2} = 3$

Use of Permutation in Cryptography

Permutations are used in the cryptography as explained in the following example.

Let we have to encrypt the word "PAK". Label P as 1, A as 2 and K as 3. Total number of encrypted words are as follow:

| | | | |
|-----|----|---|----|
| PAK | (1 | 2 | 3) |
| PKA | (1 | 3 | 2) |
| AKP | (2 | 3 | 1) |
| APK | (2 | 1 | 3) |
| KAP | (3 | 2 | 1) |
| KPA | (3 | 1 | 2) |

Let we want it to be encrypted as

APK i.e.; 2 1 3

It is decrypted as 1 2 3

= PAK

Exercise 6.2

1. Prove the following for $n \in \mathbb{N}$.

(i). ${}^n P_r = \frac{n!}{(n-r)!}$

(ii). ${}^n P_n = {}^n P_{n-1}$

(iii). ${}^n P_r = n \cdot {}^{n-1} P_{r-1}$

(iv). ${}^n P_r = {}^{n-1} P_{r+r} \cdot {}^{n-1} P_{r-1}$

(v). ${}^n P_n = 2 \cdot {}^n P_{n-2}$

2. Find n , if:

(i). ${}^n P_4 = 20 \cdot {}^n P_2$

(ii). $2^n P_3 = 100 \cdot {}^n P_2$

(iii). $16 \cdot {}^n P_3 = 13 \cdot {}^{n+1} P_3$

(iv). ${}^n P_5 = 20 \cdot {}^n P_3$

(v). $30 \cdot {}^n P_6 = {}^{n+2} P_7$

(vi). ${}^n P_5 : {}^{n-1} P_4 = 6 : 1$

(vii). ${}^n P_4 : {}^{n-1} P_3 = 9 : 1$

(viii). ${}^{n-1} P_3 : {}^{n+1} P_3 = 5 : 12$

(ix). ${}^{2n-1} P_n : {}^{2n+1} P_{n-1} = 22 : 7$

3. Find r , if:

(i). ${}^6 P_{r-1} = {}^5 P_4$

(ii). ${}^{10} P_r = 2 \cdot {}^9 P_r$

(iii). ${}^{15} P_r = 210$

(iv). ${}^{10} P_r = 3 \cdot {}^{10} P_{r-1}$

(v). $4 \cdot {}^6 P_r = {}^6 P_{r+1}$

(vi). $2 \cdot {}^6 P_{r-1} = {}^5 P_r$

(vii). ${}^{54} P_{r+3} : {}^{56} P_{r+6} = 1 : 30800$

- How many 3-digit even numbers can be formed from the digits 1, 2, 3, 4, 5, 6, if the digits are not repeated?
- How many 7-digits mobile number can be made using the digits 0 to 9, if each number starts with 5 and no digit is repeated?
- How many 4-digit numbers can be formed with the digits 1, 2, 3, 4, 5, 6 when the repetition of the digits is allowed?

7. How many numbers can be formed with the digits 1, 1, 2, 2, 3, 3, 4 so that the even digits always occupy the even places, using all the digits and no digit is repeated?
8. In how many ways can a party of 4 men and 5 women be seated at a round table so that no two women are adjacent?
9. How many different signals can be made with 2 blue, 3 yellow and 4 green flags using all at a time.
10. How many words can be formed from the letters of the word FRIDAY? How many of them will end with F?
11. How many different permutations of the word STATESMAN can be formed using all letters at a time?
12. Find the number of arrangement of letters of the word VOWEL in which vowels may occupy odd places?
13. In how many ways can letters of word MACHINE be arranged so that all the vowels are never together?
14. How many 3 letter words (with or without meaning) can be formed out of the letter of the word ENGLISH, if the repetition of the letter is not allowed.
15. Fatima wants to arrange 5 Mathematics, 3 English and 2 Urdu books on book shelf. If the books on the same subjects are together, find all possible arrangements.
16. How many odd numbers can be formed by using the digits 1, 2, 3, 4, 5, 6 when repetition of digits is not allowed.
17. How many 4-digit odd numbers can be formed using the digits 1, 2, 3, 4 and 5 if no digit is repeated.
18. How many odd numbers less than 10,000 can be formed using the digits 0, 2, 3, 5, 6 without repeating the digits.
19. The chief secretary of Sindh calls a meeting of 10 secretaries. In how many ways they be seated at a round table if three particular secretaries want to sit together?
20. Find the number of ways that 6 men and 6 women seated at a round table such that they occupy alternative seats.
21. Make all the permutations of the following words
WHY, SAD, TWO, MADE
22. Encrypt the word LAHORE by using the permutation:
$$(3 \ 4 \ 6 \ 1 \ 5 \ 2)$$

By labelling L as 1, A as 2 and so on.
23. Decrypt the word "TNLUMA" by using the permutation:
$$(4 \ 6 \ 3 \ 2 \ 1 \ 5)$$

6.4 Combinations

In permutation we arrange the objects in some definite order. If in the arrangements of objects their order is not important then this arrangement of objects is called **combination**.

Let, we have three objects a, b and c then $abc, acb, bac, bca, cab, cba$ all are same. In permutation we consider them all distinct, so there are 6 arrangements, but in combination all these are same (since order is not important). Hence, we consider all these arrangements same and consider them a single combination. The combination of r objects taken out of n distinct objects is denoted by ${}^n C_r$ or $\binom{n}{r}$.

6.4.1 Prove that ${}^n C_r = \binom{n}{r} = \frac{n!}{r!(n-r)!}$

Proof: Let we have n distinct objects and we want to take r at a time where, $0 \leq r \leq n$. Let the total number of combinations be . i.e. X we take these r objects in some order then total number of ways are $r!$. But in combinations all these $r!$ ways will be treated as same that is one way.

$$\begin{aligned} \text{i.e. } r! \text{ combination} &= 1 \text{ permutations} \\ \Rightarrow r! X &= 1 \text{ permutation} \end{aligned}$$

Since, total number of permutations are ${}^n P_r$. So,

$$\begin{aligned} \therefore X r! &= {}^n P_r \\ \Rightarrow X &= \frac{1}{r!} {}^n P_r = \frac{1}{r!} \cdot \frac{n!}{(n-r)!} \\ \Rightarrow {}^n C_r &= \binom{n}{r} = \frac{n!}{r!(n-r)!} \end{aligned}$$

Deductions

(i) $\binom{n}{n} = \binom{n}{0} = 1$
Since, $\binom{n}{r} = \frac{n!}{r!(n-r)!}$
Putting $r = n$; we have
$$\binom{n}{n} = \frac{n!}{n!(n-n)!} = \frac{n!}{n!0!} = \frac{1}{0!} = \frac{1}{1} = 1$$

Now taking $r = 0$; we have

$$\binom{n}{0} = \frac{n!}{0!(n-0)!} = \frac{n!}{1 \cdot n!} = \frac{1}{1} = 1$$

Thus $\binom{n}{n} = \binom{n}{0} = 1$

(ii) $\binom{n}{r} = \binom{n}{n-r}$

Since, $\binom{n}{r} = \frac{n!}{r!(n-r)!}$

Replacing r by $n-r$, we have

$$\begin{aligned} \therefore \binom{n}{n-r} &= \frac{n!}{(n-r)![n-(n-r)]!} = \frac{n!}{(n-r)!(n-n+r)!} \\ &= \frac{n!}{(n-r)!r!} = \binom{n}{r} \end{aligned}$$

$$\begin{aligned} \therefore \binom{n}{n-r} &= \binom{n}{r} \\ \text{(iii)} \quad \binom{n}{1} &= \binom{n}{n-1} = n \end{aligned}$$

Since, $\binom{n}{r} = \frac{n!}{r!(n-r)!}$

Putting $r = 1$; we have

$$\binom{n}{1} = \frac{n!}{1!(n-1)!} = \frac{n(n-1)!}{(n-1)!} = n$$

Now put $r = n - 1$

$$\binom{n}{n-1} = \frac{n!}{(n-1)!(n-(n-1))!} = \frac{n(n-1)!}{(n-1)!(n-n+1)!} = \frac{n(n-1)!}{(n-1)!1!} = n$$

Hence, $\binom{n}{1} = \binom{n}{n-1} = n$

$$\text{(iv)} \quad \binom{n}{r} + \binom{n}{r-1} = \binom{n+1}{r}$$

Since, $\binom{n}{r} = \frac{n!}{r!(n-r)!}$ (1)

Replacing r by $r - 1$

$$\binom{n}{r-1} = \frac{n!}{(r-1)!(n-(r-1))!} = \frac{n!}{(r-1)!(n-r+1)!}$$
 (2)

Adding (1) and (2)

$$\begin{aligned} \binom{n}{r} + \binom{n}{r-1} &= \frac{n!}{r!(n-r)!} + \frac{n!}{(r-1)!(n-r+1)!} \\ &= \frac{n!}{r(r-1)!(n-r)!} + \frac{n!}{(r-1)!(n-r+1)(n-r)!} \\ &= \frac{n!}{(r-1)!(n-r)!} \left[\frac{1}{r} + \frac{1}{n-r+1} \right] \\ &= \frac{n!}{(r-1)!(n-r)!} \cdot \frac{n-r+1+r}{r(n-r+1)} \\ &= \frac{n!}{(r-1)!(n-r)!} \cdot \frac{n+1}{r(n-r+1)} \\ &= \frac{n!(n+1)}{(r-1)!r(n-r)!(n-r+1)} = \frac{(n+1)!}{r!(n+1-r)!} \\ &= \binom{n+1}{r} \end{aligned}$$

Example: 10 students applied for 6 HEC scholarships. In how many ways can these 6 be chosen?

Solution:

Total number of students = $n = 10$

Number of students to be chosen = $r = 6$

Because for this selection order of the students is not necessary.

So, this selection can be made in:

$${}^{10}C_6 = \frac{10!}{6!(10-6)!} = \frac{10!}{6!4!} = \frac{10 \cdot 9 \cdot 8 \cdot 7 \cdot 6!}{6!4 \cdot 3 \cdot 2 \cdot 1} = 210 \text{ ways}$$

Example: Find the value of n if ${}^nC_2 = 10$

Solution: Given ${}^nC_2 = 10$

$$\begin{aligned} \frac{n!}{2!(n-2)!} &= 10 \\ \Rightarrow \frac{n(n-1)(n-2)!}{(n-2)!} &= 10 \times 2 \\ \Rightarrow n(n-1) &= 20 \\ \Rightarrow n^2 - n - 20 &= 0 \\ \Rightarrow n^2 - 5n + 4n - 20 &= 0 \\ \Rightarrow n(n-5) + 4(n-5) &= 0 \\ \Rightarrow (n-5)(n+4) &= 0 \\ \Rightarrow n-5 = 0 \text{ or } n+4 &= 0 \\ \Rightarrow n = 5 \text{ or } n = -4 \end{aligned}$$

$n = -4$ is not possible as value of n is positive.

Hence, $n = 5$

Check Point



There are 8 men and 10 women and you need to form a committee of 5 men and 6 women. In how many ways can the committee be formed?

Exercise 6.3

1. Prove the following for $n \in \mathbb{N}$.

(i) ${}^nC_r = \frac{n!}{r!(n-r)!}$ (ii) $n \cdot {}^{n-1}C_{r-1} = (n-r+1) {}^nC_{r-1}$ (iii) $r {}^nC_r = (n-r+1) {}^nC_{r-1}$

(iv) ${}^{n-1}C_{r-1} + {}^{n-1}C_r = {}^nC_r$ (v) ${}^nC_r + {}^nC_{r-1} = {}^{n+1}C_r$ (vi) $2^n C_n = \frac{2^n \cdot [1 \cdot 3 \cdot 5 \cdots (2n-1)]}{n!}$

(vii) ${}^nC_p = {}^nC_q \Rightarrow p = q$ or $p + q = n$ (viii) ${}^nC_r + 2 {}^nC_{r-1} + {}^nC_{r-2} = {}^{n+2}C_r$

(ix) $r {}^nC_r = n {}^{n-1}C_{r-1}$ (x) The product of k consecutive integers is divisible by $k!$.

2. Find n , if:

(i) ${}^nC_5 = {}^nC_8$ (ii) ${}^nC_{15} = {}^nC_7$ (iii) ${}^nC_{50} = {}^nC_1$ (iv) $2^n C_3 : {}^nC_3 = 11 : 1$

(v) ${}^nC_6 : {}^{n-3}C_3 = 33 : 4$ (vi) $2^n C_3 : {}^nC_2 = 12 : 1$

3. Find r , if:

(i) ${}^{15}C_{3r} = {}^{15}C_{r+3}$ (ii) ${}^8C_r - {}^7C_3 = {}^7C_2$ (iii) ${}^{16}C_r = {}^{16}C_{r+4}$ (iv) ${}^{15}C_r : {}^{15}C_{r-1} = 11 : 5$

4. Find n and r , if:

(i) ${}^n C_{r-1} : {}^n C_r : {}^n C_{r+1} = 6 : 14 : 21$

(ii) ${}^n C_{r-1} : {}^n C_r : {}^n C_{r+1} = 3 : 4 : 5$

(iii) ${}^{n+1} C_{r+1} : {}^n C_r : {}^{n-1} C_{r-1} = 22 : 12 : 6$

(iv) ${}^n C_r : {}^n C_{r+1} : {}^n C_{r+2} = 1 : 2 : 3$

5. In how many ways can 11 players be chosen out of 16 if

(i) there is no restriction.

(ii) a particular player is always chosen.

6. Out of 5 men and 3 women, a committee of 3 is to be formed. In how many ways can it be formed if at least one man is selected?

7. A committee of 5 members is to be formed out of 6 men and 4 women. In how many ways can it be done if it has (i) exactly 2 women (ii) at least 2 women (iii) at most 2 women?

8. There are 10 points on a circle. Find the number of (i) lines (ii) triangles that can be drawn?

9. Find the number of diagonals in n sided polygon?

10. In how many ways a group of 10 girls can be divided into two groups of 3 and 7 girls.

11. Number of diagonals in n -sided polygon is 35. Find the number n ?

12. For the post of 6 officers, there are 100 applicants, 2 posts are reserved for serving candidates and remaining for others. There are 20 serving candidates among the applicants. In how many ways this selection can be made?

13. In an examination, a candidate has to pass in each of 6 subjects. In how many ways he cannot qualify the examination?

14. A question paper has three parts A, B and C each containing 8 questions. If a student has to choose 5 questions from A, and 3 questions each from B and C. In how many ways can he choose the questions?

I have Learnt

- Knowing Kramp's factorial notation to express the product of first n natural numbers by $n!$.
- Recognizing the fundamental principle of counting and illustrating this principle using tree diagram.
- Defining permutation of n different objects taken r at a time and proof of formula of permutation.
- Finding out the arrangement of different objects including around a circle.
- Defining combination of n different objects taken r at a time.
- Proving formula of combination and solving problems involving combination.
- Applying the above formulas for permutation and combination to solve the real world word problems.

Review Exercise

1. Select the correct option in the following.
 - (i) If ${}^3P_3 = {}^nP_4$ then value of n is:
a. 5 b. 6 c. 7 d. 8
 - (ii) Number of ways of arrangement of the word "GARDEN":
a. 480 b. 600 c. 720 d. 840
 - (iii) The product of r consecutive positive numbers is divisible by:
a. $r!$ b. $(r+1)!$ c. $r! + 1$ d. $2r!$
 - (iv) The total number of 6-digit number in which all the odd and only odd digits appear is:
a. $\frac{5}{2}6!$ b. $6!$ c. $\frac{1}{2}6!$ d. $\frac{3}{2}6!$
 - (v) Let $A = \{1, 2, 3, \dots, 20\}$. Find the number of ways that the integer chosen is a prime number is:
a. 3 b. 5 c. 7 d. 8
 - (vi) From $A = \{1, 3, 5, 7, 9\}$ and $B = \{2, 4, 6, 8\}$ if a cartesian product $A \times B$ is chosen, then the number of ways that $a + b = 9$ is:
a. 0 b. 2 c. 3 d. 4
 - (vii) A student has to answer 10 out of 12 questions in an examination such that he must choose at least 4 from first five questions. The number of choices is:
a. 30 b. 35 c. 40 d. 45
 - (viii) If ${}^nC_4 = {}^nC_{10}$ then value of n is:
a. 10 b. 12 c. 13 d. 14
 - (ix) If ${}^{15}C_{3r} = {}^{15}C_{r+3}$ then value of r is:
a. 1 b. 2 c. 3 d. 4
 - (x) The number of ways in which r letters can be posted in n letter boxes in a town is:
a. nC_r b. nP_r c. r^n d. n^r
2. How many words can be formed by using four distinct alphabets?
3. How many 3-digit numbers are there which have 0 at unit place?
4. How many six-digit numbers can be formed using the digits 0, 2, 3, 4, 5, 7 without repeating.
5. The number of ways of arranging 7 keys in a key chain.
6. Twelve persons are seated at a round table. Find the number of ways of their arrangement if two particular persons don't want to sit together.

UNIT
07

MATHEMATICAL INDUCTION AND BINOMIAL THEOREM

After studying this unit, students will be able to:

- Describe a mathematical argument, identify the base case, induction of hypothesis and a precise conclusion.
- Apply the principle of mathematical induction to prove statements, identities, divisibility of numbers and summation formulae.
- Evaluate and justify conclusions, communicating a position clearly in an appropriate mathematical form in daily life.
- State and apply the Binomial Theorem to expand expressions of the form $(a + b)^n$ where n is a positive integer.
- Describe Binomial Theorem as expansion of binomial powers restricted to the set of natural numbers.
- Calculate binomial coefficients using Pascal's triangle.
- Expand using the binomial theorems, and use appropriate techniques to simplify the expression.
- Find an approximate value using binomial theorem.
- Use binomial theorem to find the remainder when a number to some large exponent is divided by a number.
- Use binomial theorem to find the last digit of a number, test the divisibility by a number and compare two large numbers.
- Apply concepts of Mathematical induction and binomial theorem to real world problems such as (puzzles, domino effects, Pascal's triangle, Economic forecasting, Rankings, Variable subletting).

The concept of mathematical induction was first utilized by the Italian scientist Francesco Maurolico in 1575. During the seventeenth century, both Pierre de Fermat and Blaise Pascal also employed this technique, with Fermat referring to it as the "method of infinite descent." In 1883, Augustus De Morgan, renowned for De Morgan's laws, provided a meticulous description of the process and named it mathematical induction.

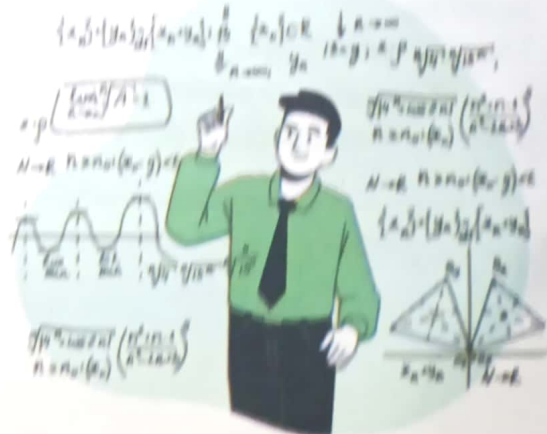

7.1 Mathematical Induction

To illustrate the idea of mathematical induction, envision an infinite sequence of dominoes arranged in a line, where if one domino falls backward, it causes the next one to fall backward as well. Now, suppose the first domino falls backward. What occurs next? . . . They all fall down.

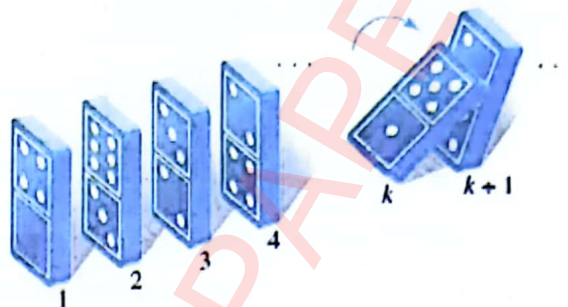

(Figure 7.1)

If the k th domino falls backward, it will also push the $(k + 1)$ th domino backward.

To establish the connection between this visualization and the principle of mathematical induction, consider the sentence "The n th domino falls backward", denoted as $P(n)$. It is known that for every $k \geq 1$, if $P(k)$ is true (the k th domino falls backward), then $P(k + 1)$ is also true (the $(k + 1)$ th domino falls backward). Additionally, it is given that $P(1)$ is true (the first domino falls backward). Hence, according to the principle of mathematical induction, $P(n)$ (the n th domino falls backward) is true for every integer $n \geq 1$.

7.1.2 Principle of Mathematical Induction

Example: Use the method of mathematical induction to prove that

$$1.2 + 2.3 + 3.4 + \dots + n(n + 1) = \frac{n(n + 1)(n + 2)}{3}$$

for all positive integers ' n '.

Solution:

Here the proposition $P(n)$ is:

$$1.2 + 2.3 + 3.4 + \dots + n(n + 1) = \frac{n(n + 1)(n + 2)}{3}$$

Step 1: (Basis Step)

$P(1)$ is true; since

$$1.2 = \frac{1(1+1)(1+2)}{3}$$

$$\Rightarrow 2 = 2$$

Step 2: (Inductive Step)

$P(k + 1)$ is true whenever $P(k)$ is true.

Let $P(n)$ is true for $n = k$. i.e.;

$$1.2 + 2.3 + 3.4 + \dots + k(k + 1) = \frac{k(k + 1)(k + 2)}{3}$$

Now we prove that $P(k + 1)$ is also true. For this we add $(k + 1)(k + 1 + 1)$ on both sides.

$$\begin{aligned} 1.2 + 2.3 + 3.4 + \dots + k(k + 1) + (k + 1)(k + 1 + 1) \\ = \frac{k(k + 1)(k + 2)}{3} + (k + 1)(k + 1 + 1) \end{aligned}$$

Key Facts



The two steps are involved in the mathematical induction. First one is known as basis step and next one is known as inductive step.

$$\begin{aligned}
 1.2 + 2.3 + 3.4 + \dots + k(k+1) + (k+1)(k+1+1) &= \frac{k(k+1)(k+2)}{3} + (k+1)(k+2) \\
 &= (k+1)(k+2) \left[\frac{k}{3} + 1 \right] = (k+1)(k+2) \left[\frac{k+3}{3} \right] \\
 &= \frac{(k+1)(k+1+1)(k+1+2)}{3}
 \end{aligned}$$

This shows that $P(k+1)$ is true. Thus, it is true for all positive integers.

Example: Use the method of mathematical induction to prove that

$$\left(1 - \frac{1}{2}\right) \left(1 - \frac{1}{3}\right) \left(1 - \frac{1}{4}\right) \dots \left(1 - \frac{1}{n+1}\right) = \frac{1}{n+1}$$

for all positive integers 'n'.

Solution:

Here the proposition $P(n)$ is:

$$\left(1 - \frac{1}{2}\right) \left(1 - \frac{1}{3}\right) \left(1 - \frac{1}{4}\right) \dots \left(1 - \frac{1}{n+1}\right) = \frac{1}{n+1}$$

Step 1: (Basis Step)

For $n = 1$; $P(1)$ is

$$\begin{aligned}
 \left(1 - \frac{1}{2}\right) &= \frac{1}{1+1} \\
 \Rightarrow \frac{1}{2} &= \frac{1}{2}
 \end{aligned}$$

This shows that $P(1)$ is true.

Step 2: (Inductive Step)

In this step we will prove that $P(k+1)$ is true whenever $P(k)$ is true.

Let it is true for $n = k$; i.e.;

$$\left(1 - \frac{1}{2}\right) \left(1 - \frac{1}{3}\right) \left(1 - \frac{1}{4}\right) \dots \left(1 - \frac{1}{k+1}\right) = \frac{1}{k+1}$$

Now multiply both sides by $\left(1 - \frac{1}{k+1+1}\right)$.

$$\begin{aligned}
 \left(1 - \frac{1}{2}\right) \left(1 - \frac{1}{3}\right) \left(1 - \frac{1}{4}\right) \dots \left(1 - \frac{1}{k+1}\right) \left(1 - \frac{1}{k+1+1}\right) &= \left(\frac{1}{k+1}\right) \left(1 - \frac{1}{k+1+1}\right) \\
 &= \left(\frac{1}{k+1}\right) \left(1 - \frac{1}{k+2}\right) = \left(\frac{1}{k+1}\right) \left(\frac{k+2-1}{k+2}\right) = \left(\frac{1}{k+1}\right) \left(\frac{k+1}{k+2}\right) = \frac{1}{k+2} \\
 &= \frac{1}{k+1+1}
 \end{aligned}$$

This shows that it is true for $n = k+1$ i.e.; $P(k+1)$ is true.

Thus, it is true for all positive integers n .

Example: Use the method of mathematical induction to show that $n^2 - 3n + 4$ is an even (i.e.; divisible by 2) for all positive integers n .

Solution:

The proposition $P(n)$ $n^2 - 3n + 4$ is an even number for all positive integers.

Step 1: (Basis Step)

For $n = 1$; $P(1)$ is $1^2 - 3(1) + 4 = 2$ which is an even number. Thus $P(1)$ is true.

Step 2: (Inductive Step)

$P(k + 1)$ is true when $P(k)$ is true.

Let $P(k)$ is true i.e.; $k^2 - 3k + 4$ is an even. Now $P(k + 1)$ is:

$$\begin{aligned}
(k + 1)^2 - 3(k + 1) + 4 &= k^2 + 2k + 1 - 3k - 3 + 4 \\
&= (k^2 - 3k + 4) + (2k + 1 - 3) \\
&= (k^2 - 3k + 4) + (2k - 2) \\
&= (k^2 - 3k + 4) + 2(k - 1)
\end{aligned}$$

Which is an even because it is sum of two even numbers $(k^2 - 3k + 4)$ and $2(k - 1)$.

$\Rightarrow P(k + 1)$ is true. Thus, it is true for all positive integers n .

Example: Use the method of mathematical induction to show that $3^n > n^2$ for all positive integers n .

Solution:

The proposition $P(n)$ is $3^n > n^2$ for all positive integers n .

Step 1: (Basis Step)

For $n = 1$

$P(1)$ is $3^1 > 1^2 \Rightarrow 3 > 1$

$\Rightarrow P(1)$ is true.

Step 2: (Inductive Step)

$P(k + 1)$ is true when $P(k)$ is true.

Let it is true for $n = k$. i.e.;

$$3^k > k^2$$

Now $3^{k+1} = 3 \times 3^k = 3^k + 3^k + 3^k > 3^k + 3^k$

$$\Rightarrow 3^{k+1} > k^2 + 3^k \quad \because 3^k > k^2 \text{ is true for } n = k$$

Also $3^k > 2k + 1$ for $k > 1$

$$\Rightarrow 3^{k+1} > k^2 + 2k + 1$$

$$\Rightarrow 3^{k+1} > (k + 1)^2$$

This shows that $P(k + 1)$ is true. Thus, true for all positive integers n .

Example: Use the method of mathematical induction to show that

$$4 + 4.6 + 4.6^2 + 4.6^3 + \dots + 4.6^n = \frac{4(6^{n+1}-1)}{5} \text{ for all positive integers } n.$$

Solution:

We have to prove the proposition $P(n)$ that $4 + 4.6 + 4.6^2 + 4.6^3 + \dots + 4.6^n = \frac{4(6^{n+1}-1)}{5}$

by mathematical induction.

Step 1: (Basis Step)

For $n = 0$

$$4 = \frac{4(6^{0+1} - 1)}{5} = 4 \times \frac{5}{5} = 4$$

$\Rightarrow P(0)$ is true

Step 2: (Inductive Step)

$P(k + 1)$ is true when $P(k)$ is true.

Let it is true for $n = k$. i.e.;

$$4 + 4.6 + 4.6^2 + 4.6^3 + \dots + 4.6^k = \frac{4(6^{k+1} - 1)}{5} \quad (1)$$

Now we have to show that proposition is true for $n = k + 1$.

Adding 4.6^{k+1} on both sides of equation (1), we get:

$$\begin{aligned} 4 + 4.6 + 4.6^2 + 4.6^3 + \dots + 4.6^k + 4.6^{k+1} &= \frac{4(6^{k+1} - 1)}{5} + 4.6^{k+1} \\ &= \frac{4. (6^{k+1} - 1 + 5.6^{k+1})}{5} \\ &= \frac{4. (6.6^{k+1} - 1)}{5} = \frac{4. (6^{k+2} - 1)}{5} \end{aligned}$$

This shows that $P(k + 1)$ is true. Thus, true for all positive integers n .

Exercise 7.1

By the method of the mathematical induction prove the following when n is an integer.

1. $1 + 2 + 3 + \dots + n = \frac{n(n+1)}{2} \quad \forall n \geq 1$
2. $1^2 + 2^2 + 3^2 + \dots + n^2 = \frac{n(n+1)(2n+1)}{6} \quad \forall n \geq 1$
3. $1^3 + 2^3 + 3^3 + \dots + n^3 = \frac{n^2(n+1)^2}{4} \quad \forall n \geq 1$
4. $\frac{1}{1.4} + \frac{1}{4.7} + \frac{1}{7.10} + \dots + \frac{1}{(3n-2)(2n+1)} = \frac{n}{3n+1} \quad \forall n \geq 1$
5. $1^2 + 3^2 + 5^2 + \dots + (2n-1)^2 = \frac{n(4n^2-1)}{3} \quad \forall n \geq 1$
6. $4^3 + 4^4 + 4^5 + \dots + 4^n = \frac{n(4^n-16)}{3} \quad \forall n \geq 3$
7. $\frac{1}{1.2} + \frac{1}{2.3} + \frac{1}{3.4} + \dots + \frac{1}{n(n+1)} = \frac{n}{n+1} \quad \forall n \geq 1$
8. $\frac{3}{1.2.2} + \frac{4}{2.3.2^2} + \frac{5}{3.4.2^3} + \dots + \frac{n+2}{n(n+1).2^n} = 1 - \frac{1}{(n+1).2^n} \quad \forall n \geq 1$
9. $\frac{5}{1.2.3} + \frac{6}{2.3.4} + \frac{7}{3.4.5} + \dots + \frac{n+4}{n(n+1)(n+2)} = \frac{n(3n+7)}{2(n+1)(n+2)} \quad \forall n \geq 1$
10. $7 + 77 + 777 + \dots + 777 \dots 7_n \text{ times} = \frac{7}{81} (10^{n+1} - 9n - 10) \quad \forall n \geq 1$
11. $1^3 + 3^3 + 5^3 + \dots + (2n+1)^3 = (n+1)^2(2n^2 + 4n + 1) \quad \forall n \geq 0$
12. $1.2^0 + 2.2^1 + 3.2^2 + \dots + n.2^{n-1} = (n-1).2^n + 1 \quad \forall n \geq 1$

13. $1 \cdot 1! + 2 \cdot 2! + 3 \cdot 3! + \dots + n \cdot n! = (n + 1)! - 1$ $\forall n \geq 1$
14. $\left(1 - \frac{1}{2^2}\right) \left(1 - \frac{1}{3^2}\right) \left(1 - \frac{1}{4^2}\right) \dots \left(1 - \frac{1}{n^2}\right) = \frac{n+1}{2n}$ $\forall n \geq 2$
15. $\left(\frac{1}{1} \cdot \frac{1}{2}\right) \left(\frac{1}{3} \cdot \frac{1}{4}\right) \left(\frac{1}{5} \cdot \frac{1}{6}\right) \dots \left(\frac{1}{2n+1} \cdot \frac{1}{2n+2}\right) = \frac{1}{(2n+2)!}$ $\forall n \geq 0$
16. $1 - 2 + 2^2 - 2^3 + \dots + (-1)^n 2^n = \frac{1 - (-2)^{n+1}}{3}$ $\forall n \geq 1$
17. $\binom{n}{0} + \binom{n}{1} + \binom{n}{2} + \dots + \binom{n}{n} = 2^n$ $\forall n \geq 0$
18. $\binom{n}{1} + 2 \binom{n}{2} + 3 \binom{n}{3} + \dots + n \binom{n}{n} = n \cdot 2^{n-1}$ $\forall n \geq 1$
19. $\binom{n}{0} + \frac{1}{2} \binom{n}{1} + \frac{1}{3} \binom{n}{2} + \dots + \frac{1}{n+1} \binom{n}{n} = \frac{2^{n+1} - 1}{n+1}$ $\forall n \geq 0$

Prove the followings by mathematical induction

20. $n^3 + 2n$ is divisible by 3 $\forall n \geq 1$
21. 6 is a factor of $n(n^2 + 5)$ $\forall n \geq 1$
22. $\frac{n(3n^4 + 5n^2 + 7)}{15}$ is a rational number.
23. $4^n + 15n - 1$ is divisible by 9 $\forall n \geq 1$
24. $7^n - 2^n$ is divisible by 5 $\forall n \geq 0$

Prove the followings inequalities by using the method of mathematical induction.

25. $2^n < (n + 1)!$ $\forall n \geq 2$
26. $5^n + 9 < 6^n$ $\forall n \geq 2$
27. If $h > -1$ then $1 + nh \leq (1 + h)^n$ $\forall n \geq 0$
28. $\binom{2n}{n} < 2^{2n-2}$ $\forall n \geq 5$
29. $\sqrt[n]{n} < 2 - \frac{1}{n}$ $\forall n \geq 2$
30. $1 + 3n \leq 4^n$ $\forall n \geq 0$
31. $n^3 > 2n + 1$ $\forall n \geq 2$
32. $n! > n^2$ $\forall n \geq 4$

7.2 Binomial Theorem

'Bi' mean two and 'nominal' mean terms. So, binomial mean an algebraic expression consisting of two terms. e.g., $(x + y)$, $\left(\frac{1}{x} - \frac{1}{2}\right)$, $\left(x^2 + \frac{1}{x}\right)$ etc all are binomials.

Often, we need some positive integral powers of binomial like square, cube or even higher powers. Higher is the power the longer will be the expansion. To handle such problem we use binomial theorem. General form of binomial expression is $(a + b)^n$ where n is a positive integer. We can expand the expression $(a + b)^n$ by using binomial theorem. Another way to expand $(a + b)^n$ is the use of Pascal's triangle.

7.2.1 Pascal's Triangle

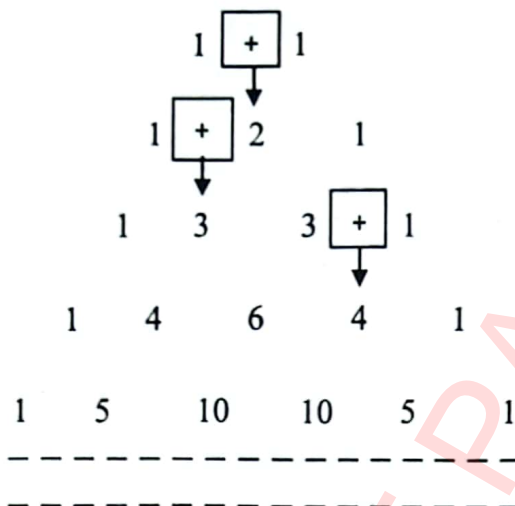

This triangle of positive integers is known as Pascal's triangle. How the Pascal triangle is helpful in the binomial expansion; observe some positive integral powers of $(a + b)^n$.

for $n = 1$ $(a + b)^1 = a + b$
 for $n = 2$ $(a + b)^2 = a^2 + 2ab + b^2$
 for $n = 3$ $(a + b)^3 = a^3 + 3a^2b + 3ab^2 + b^3$
 for $n = 4$ $(a + b)^4 = a^4 + 4a^3b + 6a^2b^2 + 4ab^3 + b^4$

Observe that the binomial coefficients in the above expansion are.

for $n = 1$ 1 1
 for $n = 2$ 1 2 1
 for $n = 3$ 1 3 3 1
 for $n = 4$ 1 4 6 4 1

Which are same as the first four rows of the Pascal's triangle.

In this way we can find the binomial coefficients from the Pascal triangle by considering its n^{th} row; for the expansion of $(a + b)^n$. Also from the above expansion note that, expansion starts with a^n and in each next term exponent of a is decreased by 1 and the exponent of b is increased by 1. The expansion ends with the term b^n .

Key Facts



Expansion by using Pascal's triangle is convenient when n is a small positive integer.

Example: Expand $(1 + 2x)^6$ with the help of pascal's triangle.

Solution:

Here $a = 1$; $b = 2x$ and $n = 6$. For the binomial coefficients we need the 6th row of the Pascal's triangle.

Here $a = 1$; $b = 2x$ and $n = 6$. For the binomial coefficients we need the 6th row of the Pascal's triangle.

| | | | | | | |
|---------------------|---|---|---|---|---|---|
| 1 st Row | → | 1 | 1 | | | |
| 2 nd Row | → | 1 | 2 | 1 | | |
| 3 rd Row | → | 1 | 3 | 3 | 1 | |
| 4 th Row | → | 1 | 4 | 6 | 4 | 1 |

| | | | | | | | | |
|---------------------|--|---|---|----|----|----|---|---|
| 5 th Row | | 1 | 5 | 10 | 10 | 5 | 1 | |
| 6 th Row | | 1 | 6 | 15 | 20 | 15 | 6 | 1 |

Thus

$$\begin{aligned}
 (1 + 2x)^2 &= 1(1)^6 + 6(1)^5(2x) + 15(1)^4(2x)^2 + 20(1)^3(2x)^3 + 15(1)^2(2x)^4 + 6(1)^1(2x)^5 + 1(2x)^6 \\
 &= 1(1) + 6(2x) + 15(4x^2) + 20(8x^3) + 15(16x^4) + 6(32x^5) + 64x^6 \\
 &= 1 + 12x + 60x^2 + 160x^3 + 240x^4 + 192x^5 + 64x^6
 \end{aligned}$$

Example: Expand $(2 - \frac{1}{x})^5$ with the help of Pascal's triangle.

Solution:

$$\left(2 - \frac{1}{x}\right)^5 = \left[2 + \left(-\frac{1}{x}\right)\right]^5$$

Here $a = 2$; $b = -\frac{1}{x}$ and $n = 5$. For binomial coefficients we need 5th row of the Pascal's triangle.

| | | | | | | | |
|---------------------|--|---|---|----|----|---|---|
| 1 st Row | | 1 | 1 | | | | |
| 2 nd Row | | 1 | 2 | 1 | | | |
| 3 rd Row | | 1 | 3 | 3 | 1 | | |
| 4 th Row | | 1 | 4 | 6 | 4 | 1 | |
| 5 th Row | | 1 | 5 | 10 | 10 | 5 | 1 |

Therefore

$$\begin{aligned}
 \left[2 + \left(-\frac{1}{x}\right)\right]^5 &= 1(2)^5 + 5(2)^4\left(-\frac{1}{x}\right) + 10(2)^3\left(-\frac{1}{x}\right)^2 + 10(2)^2\left(-\frac{1}{x}\right)^3 + 5(2)^1\left(-\frac{1}{x}\right)^4 + 1\left(-\frac{1}{x}\right)^5 \\
 &= 1(32) + 5(16)\left(-\frac{1}{x}\right) + 10(8)\left(\frac{1}{x^2}\right) + 10(4)\left(-\frac{1}{x^3}\right) + 5(2)\left(\frac{1}{x^4}\right) + 1\left(-\frac{1}{x^5}\right) \\
 &= 32 - \frac{80}{x} + \frac{80}{x^2} - \frac{40}{x^3} + \frac{10}{x^4} - \frac{1}{x^5}
 \end{aligned}$$

7.2.2 Binomial Theorem

Statement: If a and b are any two real numbers and n is a positive integer then

$$(a + b)^n = \binom{n}{0} a^n b^0 + \binom{n}{1} a^{n-1} b^1 + \binom{n}{2} a^{n-2} b^2 + \dots + \binom{n}{n-1} a^1 b^{n-1} + \binom{n}{n} a^0 b^n$$

Proof:

We will prove this with the help of mathematical induction.

Step 1: (Basis Step)

For $n = 1$

$$(a + b)^1 = \binom{1}{0} a^1 b^0 + \binom{1}{1} a^{1-1} b^1 = (1)a(1) + (1)(1)b = a + b$$

True for $n = 1$

Step 2: (Inductive Step)

Let it is true for $n = k$. i.e.;

$$(a + b)^k = \binom{k}{0} a^k b^0 + \binom{k}{1} a^{k-1} b^1 + \binom{k}{2} a^{k-2} b^2 + \dots + \binom{k}{k-1} a b^{k-1} + \binom{k}{k} a^0 b^k$$

Now we will prove that it is true for $n = k + 1$. For this multiply the above equation by $a + b$ on both sides.

$$\begin{aligned} (a + b)(a + b)^k &= (a + b) \left[\binom{k}{0} a^k b^0 + \binom{k}{1} a^{k-1} b^1 + \binom{k}{2} a^{k-2} b^2 + \dots + \binom{k}{k-1} a b^{k-1} + \binom{k}{k} a^0 b^k \right] \\ \Rightarrow (a + b)^{k+1} &= a \left[\binom{k}{0} a^k b^0 + \binom{k}{1} a^{k-1} b^1 + \binom{k}{2} a^{k-2} b^2 + \dots + \binom{k}{k-1} a b^{k-1} + \binom{k}{k} a^0 b^k \right] \\ &\quad + b \left[\binom{k}{0} a^k b^0 + \binom{k}{1} a^{k-1} b^1 + \binom{k}{2} a^{k-2} b^2 + \dots + \binom{k}{k-1} a b^{k-1} + \binom{k}{k} a^0 b^k \right] \\ &= \left[\binom{k}{0} a^{k+1} b^0 + \binom{k}{1} a^k b^1 + \binom{k}{2} a^{k-1} b^2 + \dots + \binom{k}{k-1} a b^{k-1} + \binom{k}{k} a^0 b^k \right] \\ &\quad + \left[\binom{k}{0} a^k b^1 + \binom{k}{1} a^{k-1} b^2 + \binom{k}{2} a^{k-2} b^3 + \dots + \binom{k}{k-1} a b^k + \binom{k}{k} a^0 b^{k+1} \right] \end{aligned}$$

By collecting the like terms, we have,

$$\begin{aligned} (a + b)^{k+1} &= \binom{k}{0} a^{k+1} b^0 + \left[\binom{k}{1} + \binom{k}{0} \right] a^k b + \left[\binom{k}{2} + \binom{k}{1} \right] a^{k-1} b^2 + \dots + \left[\binom{k}{k-1} + \binom{k}{k} \right] a b^k \\ &\quad + \binom{k}{k} a^0 b^{k+1} \end{aligned}$$

Since,

$$\begin{aligned} \binom{k}{0} &= 1 = \binom{k+1}{0} \\ \binom{k}{k} &= 1 = \binom{k+1}{k+1} \\ \binom{k}{r-1} + \binom{k}{r} &= \binom{k+1}{r} \quad \text{for } 0 \leq r \leq k \end{aligned}$$

Thus

$$\begin{aligned} (a + b)^{k+1} &= \binom{k+1}{0} a^{k+1} b^0 + \binom{k+1}{1} a^k b + \binom{k+1}{2} a^{k-1} b^2 + \dots + \binom{k+1}{k+1-1} a b^k \\ &\quad + \binom{k+1}{k+1} a^0 b^{k+1} \end{aligned}$$

This shows that it is true for $n = k + 1$; hence it is true for all positive integer n .

Some Properties of Binomial Expansion

1. The number of terms in the expansion of $(a + b)^n$ is one more than the index n .
2. The sum of exponents of a and b in each term of the expansion of $(a + b)^n$ is n .
3. The coefficients of the terms equidistant from the beginning and the end are same.
4. If n is even then there will be odd number of terms in the expansion of $(a + b)^n$. So the middle term in this expansion is the $\left(\frac{n}{2} + 1\right)^{th} = \binom{n+2}{2}^{th}$ term.

5. If n is odd then there will be even number of terms in the expansion of $(a + b)^n$. So there will be two middle terms in the expansion; these are $\binom{n+1}{2}^{th}$ and $\binom{n+3}{2}^{th}$ terms of the expansion.
6. In the expansion of $(a + b)^n$, exponent of a is n and the exponent of b is zero in the first term. In each next term exponent of a is decreased by 1 and the exponent of b is increased by 1. In the last term exponent a becomes zero and the exponent of b is reached to n .
7. Any particular $(r + 1)^{th}$ term from beginning also known as **general term** in the expansion of $(a + b)^n$ is given by

$$T_{r+1} = \binom{n}{r} a^{n-r} b^r$$

8. A term which is at r^{th} position from the end in the expansion of $(a + b)^n$ is at $(n + 2 - r)^{th}$ position from the beginning.

Example: Expand $(x - y)^5$ using binomial theorem.

Solution:

$$\begin{aligned} (x - y)^5 &= [x + (-y)]^5 \\ &= \binom{5}{0} x^5 (-y)^0 + \binom{5}{1} x^4 (-y)^1 + \binom{5}{2} x^3 (-y)^2 + \binom{5}{3} x^2 (-y)^3 + \binom{5}{4} x^1 (-y)^4 \\ &\quad + \binom{5}{5} x^0 (-y)^5 \end{aligned} \tag{1}$$

Now the binomial coefficients are;

$$\begin{aligned} \binom{5}{0} &= \frac{5!}{0!(5-0)!} = \frac{5!}{1 \times 5!} = 1 \\ \binom{5}{1} &= \frac{5!}{1!(5-1)!} = \frac{5!}{1 \times 4!} = \frac{5 \times 4!}{4!} = 5 \\ \binom{5}{2} &= \frac{5!}{2!(5-2)!} = \frac{5!}{2! \times 3!} = \frac{5 \times 4 \times 3!}{2 \times 1 \times 3!} = 10 \\ \binom{5}{3} &= \frac{5!}{3!(5-3)!} = \frac{5!}{3! \times 2!} = \frac{5 \times 4 \times 3!}{3! \times 2 \times 1} = 10 \\ \binom{5}{4} &= \frac{5!}{4!(5-4)!} = \frac{5!}{4! \times 1!} = \frac{5 \times 4!}{4! \times 1} = 5 \\ \binom{5}{5} &= \frac{5!}{0!(5-0)!} = \frac{5!}{1 \times 5!} = 1 \end{aligned}$$

Substituting values in equation (1)

$$\begin{aligned} &= (1)x^5(-y)^0 + (5)x^4(-y)^1 + (10)x^3(-y)^2 + (10)x^2(-y)^3 + (5)x^1(-y)^4 \\ &\quad + (1)x^0(-y)^5 \\ &= x^5 - 5x^4y + 10x^3y^2 - 10x^2y^3 + 5xy^4 - y^5 \end{aligned}$$

Example: Find the constant term in the expansion of $\left(x + \frac{2}{x}\right)^{10}$.

Solution:

The constant term in the expansion is independent of ' x '.

Here $a = x$; $b = \frac{2}{x}$ and $n = 10$

The general term of binomial expansion is

$$T_{r+1} = \binom{n}{r} a^{n-r} b^r$$

Substituting the values

$$\begin{aligned} T_{r+1} &= \binom{10}{r} x^{10-r} \left(\frac{2}{x}\right)^r = \binom{10}{r} x^{10-r} \frac{2^r}{x^r} \\ &= \binom{10}{r} x^{10-2r} 2^r \end{aligned} \quad (1)$$

Term will be independent of x if the exponent of x is zero i.e.; $10 - 2r = 0 \Rightarrow 2r = 10$
 $\Rightarrow r = 5$

Putting value of r in equation (1), we have

$$\begin{aligned} T_{5+1} &= \binom{10}{5} x^0 2^5 = \frac{10!}{5!(10-5)!} \cdot (1)(32) = \frac{10!}{5!5!} \cdot 32 = \frac{10 \cdot 9 \cdot 8 \cdot 7 \cdot 6 \cdot 5!}{5 \cdot 4 \cdot 3 \cdot 2 \cdot 1 \cdot 5!} \quad (32) \\ T_6 &= 8064 \end{aligned}$$

Example: Find the 3rd term from the end in the expansion of $\left(2 - \frac{5}{\sqrt{x}}\right)^5$.

Solution: Here $a = 2$, $b = \frac{-5}{\sqrt{x}}$, $n = 5$

3rd term from the end is at $5 + 2 - 3 = 4^{\text{th}}$ from the beginning.

$$T_{r+1} = \binom{n}{r} a^{n-r} b^r$$

For fourth term, $r = 3$

Substituting the values;

$$\begin{aligned} T_{3+1} &= \binom{5}{3} 2^{5-3} \left(\frac{-5}{\sqrt{x}}\right)^3 = \frac{5!}{3!(5-3)!} 2^2 \left(\frac{-125}{x^{\frac{3}{2}}}\right) = \frac{5!}{3!2!} (4) \left(\frac{-125}{x^{\frac{3}{2}}}\right) = \frac{5 \cdot 4 \cdot 3!}{3! \cdot 2 \cdot 1} \left(\frac{-500}{x^{\frac{3}{2}}}\right) \\ T_4 &= 10 \left(-500x^{-\frac{3}{2}}\right) = -5000x^{-\frac{3}{2}} \end{aligned}$$

Example:

Find the remainder when 7^{101} is divided by 25.

Solution:

$$\begin{aligned} \frac{7^{101}}{25} &= \frac{7 \cdot 7^{100}}{25} = \frac{7 \cdot (7^2)^{50}}{25} = \frac{7(49)^{50}}{25} = \frac{7}{25} (50 - 1)^{50} \\ &= \frac{7}{25} \left[\binom{50}{0} (50)^{50} (-1)^0 + \binom{50}{1} (50)^{49} (-1)^1 + \binom{50}{2} (50)^{48} (-1)^2 + \dots + \binom{50}{49} (50)^1 (-1)^{49} \right. \\ &\quad \left. + \binom{50}{50} (50)^0 (-1)^{50} \right] \\ &= \frac{7}{25} \left[\left\{ \binom{50}{50} (50)^{50} (-1)^0 + \binom{50}{1} (50)^{49} (-1)^1 + \binom{50}{2} (50)^{48} (-1)^2 + \dots + \binom{50}{49} (50)^1 (-1)^{49} \right\} \right. \\ &\quad \left. + \binom{50}{50} \right] \end{aligned}$$

$$= \frac{7}{25} \left[(50)^{50}(-1)^0 + \binom{50}{1} (50)^{49}(-1)^1 + \binom{50}{2} (50)^{48}(-1)^2 + \dots + \binom{50}{49} (50)^1(-1)^{49} \right] + \frac{7}{25}$$

Thus, the remainder is 7.

Example: The fourth term in the expansion of $(ax + \frac{1}{x})^n$ is $\frac{5}{2}$

Find the values of a and n .

Solution:

General term of the binomial expansion is

$$T_{r+1} = \binom{n}{r} a^{n-r} b^r$$

The fourth term in the expansion of $(ax + \frac{1}{x})^n$ is

$$\Rightarrow T_{3+1} = \binom{n}{3} (ax)^{n-3} \left(\frac{1}{x}\right)^3 = \binom{n}{3} a^{n-3} x^{n-6}$$

Given that fourth term is $\frac{5}{2}$; thus

$$\binom{n}{3} a^{n-3} x^{n-6} = \frac{5}{2} \tag{1}$$

Now right side of (1) is independent of x , this needs exponent of x to be zero. i.e.; $n - 6 = 0$

$$\Rightarrow n = 6$$

Putting value of n in equation (1), we get

$$\binom{6}{3} a^{6-3} x^0 = \frac{5}{2} \Rightarrow \frac{6!}{3!(6-3)!} a^3 = \frac{5}{2} \Rightarrow \frac{6.5.4.3!}{3.2.13!} a^3 = \frac{5}{2}$$

$$\Rightarrow 20a^3 = \frac{5}{2} \Rightarrow a^3 = \frac{5}{40}$$

$$\Rightarrow a^3 = \frac{1}{8} = \left(\frac{1}{2}\right)^3$$

$$\Rightarrow a = \frac{1}{2}$$

7.2.3 Use of Pascal's Triangle and Binomial Theorem in Real World Problems

Pascal triangle and binomial theorem are used in the real-world problems such as cryptography, calculating the number of matches played in a tournament where n teams are playing, calculating the possible number of protein structure and DNA sequence.

Example: Use pascal triangle to find the possible number of heads when three coins are tossed simultaneously.

Solution:

When three coins are tossed together the following are the possible results.

HHH HHT HTH HTT THH THT TTH TTT

0 Heads = one result

1 Head = 3 results

2 Heads = 3 results

3 Heads = one result

By pascal triangle we have

Illustration

If we divide 25 by 7 the remainder is 4. We may write

$$\frac{25}{7} = 3 + \frac{4}{7}$$

Numerator of the fractional part is the remainder.

By pascal triangle we have

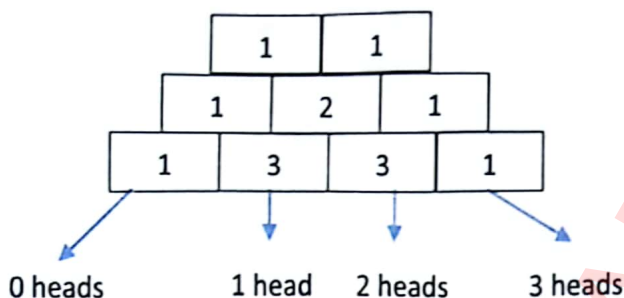

Exercise 7.2

- Expand the following with the help of Pascal's triangle.
 - $(2\sqrt{x} + \frac{1}{\sqrt{x}})^5$
 - $(\frac{3}{x} + \frac{y}{2})^6$
 - $(2 - x^{3/2})^7$
 - $(\frac{x^2}{y^2} - \sqrt{\frac{y}{x}})^5$
- Expand the followings by using binomial theorem.
 - $(\frac{2x}{3} - \frac{3}{2x})^5$
 - $(-x + y^{-1})^6$
 - $(3u - 1)^7$
 - $(a\sqrt{2} + b\sqrt{3})^5$
 - $(1 + 2x - y)^4$
 - $(\frac{1}{x} + \frac{2}{y} + \frac{3}{z})^4$
- Expand and simplify.
 - $(1 + 10x)^4 + (1 - 10x)^4$
 - $(2 - \frac{3}{x})(1 + 4x^2)$
 - $(1 + 2x + 2x^2)(1 - x)^5$
 - $(.99)^3 + (1.01)^4$
 - $(\frac{2}{x} - \frac{x}{4})^4 + (\frac{2}{x} + \frac{x}{4})^4$
 - $(a^2 + \sqrt{a^2 - 1})^4 - (a^2 - \sqrt{a^2 - 1})^4$
- Find the coefficient of the 8th term in the expansion of $(x^2 + \frac{y}{2})^{10}$.
- Find the middle term in the expansion of the following.
 - $(3x^2 - \frac{1}{2x})^{10}$
 - $(2x^2 - \frac{1}{5x})^{11}$
 - $(\frac{a}{\sqrt{x}} + \sqrt{x})^8$
 - $(a - \frac{3}{x^2})^{12}$
- Find the specified term in the following expansions.
 - Term involving b^6 in the expansion of $(\frac{a^2}{2} + 2b^2)^{10}$
 - Term involving q^8 in the expansion of $(\frac{p^2}{2} + 6q^2)^{12}$
 - Term involving x^4y^3 in the expansion of $(3x^4 - y)^4$
 - Term involving y^8x^3 in the expansion of $(y^4 - 3x)^5$
- Find the term independent of x in the expansions of the following.
 - $(2x^2 - \frac{1}{x})^{12}$
 - $(\sqrt{x} + \frac{1}{3x^2})^{10}$
- Find the r^{th} term from the end in the expansion of $(a + b)^n$ where $0 \leq r \leq n$.

9. Prove that sum of all the binomial coefficients in the expansion of $(a + b)^n$ is 2^n ; hence or otherwise prove that sum of odd coefficients is 2^{n-1} .
10. The sum of coefficients of first three terms in the expansion of $(a - \frac{3}{a^2})^n$ is 559. Find the term involving a^3 in the expansion.
11. If the coefficients of $(r - 5)^{th}$ and $(2r - 1)^{th}$ term in the expansion of $(1 + a)^{34}$ are equal; then find the value of r .
12. If the coefficients of 2nd, 3rd and 4th terms in the expansion of $(1 + x)^{2m}$ are in A.P., show that $2m^2 - 9m + 7 = 0$.
13. If coefficients of three consecutive terms in the expansion of $(1 + x)^n$ are in the ratio 6 : 33 : 110, then find the value of n and the position of terms.
14. Prove that $\binom{n}{0} + \frac{1}{2}\binom{n}{1} + \frac{1}{3}\binom{n}{2} + \dots + \frac{1}{n+1}\binom{n}{n} = \frac{2^{n+1}-1}{n+1}$
15. Prove that $\binom{n}{0} - \frac{1}{2}\binom{n}{1} + \frac{1}{3}\binom{n}{2} - \dots + \frac{(-1)^n}{n+1}\binom{n}{n} = \frac{1}{n+1}$
16. Prove that $\binom{n}{0} + \frac{1}{2}\binom{n}{1} + \frac{1}{2^2}\binom{n}{2} + \dots + \frac{1}{2^n}\binom{n}{n} = (\frac{3}{2})^n$
17. Prove that $\binom{n}{0}^2 + \binom{n}{1}^2 + \binom{n}{2}^2 + \dots + \binom{n}{n}^2 = \binom{2n}{n}$
18. Use pascals triangle to find the number of heads when six coins are tossed simultaneously.
19. If 7 coins are tossed how many times 5 heads will appear.
20. If a coin is tossed 8 times how many times 3 tails will appear.

7.3 Binomial Series

7.3.1 Expansion of $(1 + x)^n$ when n is Positive Integer

Since the index n of $(1 + x)^n$ is a positive integer; so by using the binomial theorem we have,

$$\begin{aligned} (1 + x)^n &= \binom{n}{0} (1)^n x^0 + \binom{n}{1} (1)^{n-1} x^1 + \binom{n}{2} (1)^{n-2} x^2 + \dots + \binom{n}{n} (1)^0 x^n \\ &= \frac{n!}{0!(n-0)!} (1)(1) + \frac{n!}{1!(n-1)!} (1)x + \frac{n!}{2!(n-2)!} (1)x^2 + \dots + \frac{n!}{n!0!} x^n \\ &= \frac{n!}{n!} (1) + \frac{n(n-1)!}{(n-1)!} x + \frac{n(n-1)(n-2)!}{2!(n-2)!} x^2 + \dots + \frac{n!}{n!} x^n \end{aligned}$$

$$(1 + x)^n = 1 + nx + \frac{n(n-1)}{2!} x^2 + \dots + x^n$$

The series on the right is terminating and has $(n + 1)$ number of terms.

7.3.2 Expansion of $(1 + x)^n$ when n is not Positive integers or Fractional Number

When n is not positive or fractional number then expansion of $(1 + x)^n$ is non-terminating. i.e.;

$$(1 + x)^n = 1 + nx + \frac{n(n-1)}{2!} x^2 + \frac{n(n-1)(n-2)}{3!} x^3 + \dots + \infty$$

The above series will be convergent if $|x| < 1$ or $-1 < x < 1$.

Convergent means series has a finite sum otherwise series will be divergent. We will focus only those expansions of $(1+x)^n$ which are convergent.

The series $1 + nx + \frac{n(n-1)}{2!}x^2 + \frac{n(n-1)(n-2)}{3!}x^3 + \dots$ is known as binomial series. The general term of the binomial series is given by

$$T_{r+1} = \frac{n(n-1)(n-2)\dots(n-r+1)}{r!}x^r$$

Exercise 7.3

1. Expand the followings upto four terms and also find the values of x for which the series is convergent.

(i). $(1 - \sqrt{x})^{-3}$ (ii). $(3 + \frac{2}{x})^{-\frac{1}{3}}$ (iii). $(\frac{5}{2} - \frac{3}{x^2})^{\frac{1}{2}}$
 (iv). $\frac{3+x}{3-x}$ (v). $\frac{1-2x}{\sqrt{3+\frac{x}{2}}}$ (vi). $\frac{\sqrt{x+1}}{\sqrt{1-x}}$

2. Approximate the value upto four places of decimal.

(i). $\sqrt[6]{65}$ (ii). $\sqrt{\frac{5}{3}}$ (iii). $(1.03)^{\frac{1}{3}}$ (iv). $(.95)^{\frac{2}{7}}$

3. Find the term involving x^{14} in the product of $(1+x^2)(2+\sqrt{3}x^3)^{-\frac{1}{2}}$.

4. If x is so small that its square and higher powers may be neglected then prove that:

(i) $\frac{\sqrt{2+x}(1-x)^{3/2}}{3+x} \approx \frac{\sqrt{2}}{3} (1 - \frac{19}{12}x)$ (ii) $\frac{(1+\frac{2}{3}x)^{-5} + \sqrt{4+2x}}{(4+x)^{3/1}} \approx \frac{1}{8} (3 - \frac{95}{24}x)$
 (iii) $\frac{\sqrt{9-x} + (1+\frac{3}{4}x)^{-5}}{2+x} \approx 2 - \frac{67}{24}x$

5. If x is so small that its cube and higher powers may be neglected then show that:

(i) $\frac{(1+x)^{3/2} - (1+x^2)^3}{\sqrt{1-x}} \approx -\frac{3x^2}{8}$ (ii) $\frac{(4+x)^{-2} + (1-2x)^{-5}}{(1+2x)^2} \approx \frac{3}{2} + \frac{15}{4}x + \frac{1251}{32}x^2$

6. If x is so large that $(\frac{1}{x})^2$ and higher powers may be neglected then show that:

$$\sqrt{x^2 + 25} - \sqrt{x^2 + 9} \approx \frac{8}{x}$$

7. Find the term involving x^n while simplifying $\frac{(2+x)^2}{(1+x)^3}$.

8. Identify as binomial series and find the sum of the following:

(i) $1 - \frac{3}{7} + 4. (\frac{3}{7})^2 - 8. (\frac{3}{7})^3 + \dots$

(ii) $1 - \frac{1}{15} + \frac{4}{2!.15^2} - \frac{4.7}{3!.15^3} + \dots$

(iii) $1 - \frac{2.4}{5} + \frac{3.4^2}{5^2} - \frac{4.4^3}{5^3} + \dots$

(iv) $3 - \frac{3}{18} - \frac{3}{2!.18^2} - \frac{3^2}{3!.18^3} - \dots$

9. (i) If $y = \frac{3}{2^2.1!} + \frac{3}{2^4.2!} - \frac{3}{2^6.3!} + \dots$, then show that $8y^2 + 16y - 19 = 0$.

(ii) If $\frac{2}{y} = \frac{1}{3} + \frac{1.3}{3.6} + \frac{1.3.5}{3.6.9} + \dots$ then show that $y^2 - 2y - 2 = 0$.

10. (i) If x is very nearly equal to 1 then show that $\frac{ax^b - bx^a}{x^b - x^a} \approx \frac{1}{1-x}$.

(ii) If p and q are approximately equal; then prove that $\frac{q+2p}{p+2q} \approx \left(\frac{p}{q}\right)^{1/3}$.

Hence approximate the value of $\left(\frac{2.01}{2}\right)^{1/3}$.

Applications of Binomial Theorem

The binomial theorem has a wide range of applications in Mathematics, like finding the remainder, finding the digits of a number, etc. The most common binomial theorem applications are as follows:

Finding the Last or Unit Place digit of an exponential number

Consider the table given below in which numbers are written in first column while their exponents are written in the first row and it is showing only the unit place digits.

| Powers → Numbers ↓ | 1 | 2 | 3 | 4 | 5 | 6 | 7 | 8 | 9 |
|-----------------------|---|---|---|---|---|---|---|---|---|
| 0 | 0 | 0 | 0 | 0 | 0 | 0 | 0 | 0 | 0 |
| 1 | 1 | 1 | 1 | 1 | 1 | 1 | 1 | 1 | 1 |
| 2 | 2 | 4 | 8 | 6 | 2 | 4 | 8 | 6 | 2 |
| 3 | 3 | 9 | 7 | 1 | 3 | 9 | 7 | 1 | 3 |
| 4 | 4 | 6 | 4 | 6 | 4 | 6 | 4 | 6 | 4 |
| 5 | 5 | 5 | 5 | 5 | 5 | 5 | 5 | 5 | 5 |
| 6 | 6 | 6 | 6 | 6 | 6 | 6 | 6 | 6 | 6 |
| 7 | 7 | 9 | 3 | 1 | 7 | 9 | 3 | 1 | 7 |
| 8 | 8 | 4 | 2 | 6 | 8 | 4 | 2 | 6 | 8 |
| 9 | 9 | 1 | 9 | 1 | 9 | 1 | 9 | 1 | 9 |

From the table, the unit place digits for 2 are as $2^1 = 2, 2^2 = 4, 2^3 = 8, 2^4 = 16$ and $2^5 = 32$. Since the unit digit is same as that of the number 2 therefore the cyclicity of 2 is $5 - 1 = 4$. In the same manner we can find the cyclicity of other numbers. The cyclicity of 3, 7 and 8 is also 4. For 1, 5 and 6 the unit digit remains the same for all the exponents and for 4 the unit place digit is either 4 or 6 whereas for 9 it is 9 or 1 only. Hence, we can say that if the exponent is of the form $4n, 4n + 1, 4n + 2$ or $4n + 3$ then we can easily find the value of the unit place digits of all the numbers.

Example: Find the unit digit of: (i) 17^{203} (ii) 29^{26} (iii) 36^{307}

Solution:

(i) 17^{203}

Now 203 can be written as:

$$203 = 4 \times 50 + 3$$

Since, the remainder is 3 so, $7^3 = 343$

Hence the unit place digit of 17^{203} is 3.

(ii) 29^{26}

As in case of 9 from the table we can see that there are only two values i.e.; 9 and 1.

So, write 26 as $4 \times 6 + 2$. Hence remainder is 2 that is $9^2 = 81$. Unit place digit of 9^{26} is 1.

(iii) 36^{307}

As the unit place digit is 6 which always remains 6 at unit place, so 36^{307} has 6 at unit place.

Finding Remainder Using Binomial Theorem

Example: Find the remainder when 7^{103} is divided by 25.

Solution:

$$\begin{aligned} \frac{7^{103}}{25} &= \frac{7(49)^{51}}{25} = \frac{7(50 - 1)^{51}}{25} \\ &= \frac{7(25k - 1)}{25} = \frac{175k - 25 + 25 - 7}{25} \\ &= \frac{25(7k - 1) + 18}{25} \end{aligned}$$

\therefore The remainder = 18

Example: If the fractional part of the number $\frac{2^{403}}{15}$ is $\frac{k}{15}$, then find k .

Solution:

$$\frac{2^{403}}{15} = \frac{2^3 (2^4)^{100}}{15}$$

$$= \frac{8}{15} (16)^{100} = \frac{8}{15} (15 + 1)^{100} = \frac{8}{15} (15\lambda + 1) = 8\lambda + \frac{8}{15}$$

$\therefore 8\lambda$ is an integer, fractional part = $\frac{8}{15}$

So, $k = 8$

Example Find the unit digit of (i) 17^{203} (ii) 29^{26} (iii) 36^{307}

Finding Digits of a Number

Example: Find the last two digits of the number $(13)^{10}$.

Solution:

$$(13)^{10} = (169)^5 = (170 - 1)^5$$

$$= {}^5C_0 (170)^5 - {}^5C_1 (170)^4 + {}^5C_2 (170)^3 - {}^5C_3 (170)^2 + {}^5C_4 (170) - {}^5C_5$$

$$= {}^5C_0 (170)^5 - {}^5C_1 (170)^4 + {}^5C_2 (170)^3 - {}^5C_3 (170)^2 + {}^5C_4 (170) - 1$$

A multiple of 100 + $5(170) - 1 = 100k + 849$

\therefore The last two digits are 49.

Relation between Two Numbers

Example: Which one is greater $99^{50} + 100^{50}$ or 101^{50} ?

Solution:

101^{50} can be written as:

$$101^{50} = (100 + 1)^{50} = 100^{50} + 50 \cdot 100^{49} + 25 \cdot 49 \cdot 100^{48} + \dots$$

99^{50} can be written as:

$$\Rightarrow 99^{50} = (100 - 1)^{50} = 100^{50} - 50 \cdot 100^{49} + 25 \cdot 49 \cdot 100^{48} - \dots$$

$$\text{Now, } 101^{50} - 99^{50} = 2[50 \cdot 100^{49} + 25(49)(16) 100^{47} + \dots]$$

$$= 100^{50} + 50 \cdot 49 \cdot 16 \cdot 100^{47} + \dots > 100^{50}$$

$$\therefore 101^{50} - 99^{50} > 100^{50}$$

$$\Rightarrow 101^{50} > 100^{50} + 99^{50}$$

Divisibility Test

Example: Show that $11^9 + 9^{11}$ is divisible by 10.

Solution:

$$\begin{aligned} 11^9 + 9^{11} &= (10 + 1)^9 + (10 - 1)^{11} \\ &= [{}^9C_0 \times 10^9 + {}^9C_1 \times 10^8 + \dots + {}^9C_9] + [{}^{11}C_0 \times 10^{11} - {}^{11}C_1 \times 10^{10} + \dots + {}^{11}C_{11}] \\ &= {}^9C_0 \times 10^9 + {}^9C_1 \times 10^8 + \dots + {}^9C_8 \times 10 + 1 + 10^{11} - {}^{11}C_1 \times 10^{10} + \dots + {}^{11}C_{10} \times 10 - 1 \\ &= 10[{}^9C_0 \times 10^8 + {}^9C_1 \times 10^7 + \dots + {}^9C_8 + {}^{11}C_0 \times 10^{10} - {}^{11}C_1 \times 10^9 + \dots + {}^{11}C_{10}] \\ &= 10k, \text{ which is divisible by 10.} \end{aligned}$$

Exercise 7.4

- Find the unit place digits in 27^{304} , 108^{33} , 54^{203} and 503^{43} .
- Find the remainder when:
 - 9^{205} is divided by 31.
 - 8^{205} is divided by 48.
- If fractional part of number $\frac{2^{510}}{31}$ is $\frac{k}{31}$, then find the value of k.
- Find the last one or two digits of the number where applicable.
 - 15^8
 - 37^7
 - 29^{10}
- Which of the following is a larger number?
 - $98^{50} + 100^{50}$ or 102^{50}
 - $47^{30} + 50^{30}$ or 53^{30}
- Show that $12^{15} + 8^{15}$ is divisible by 10.
- Show that $22^{25} + 18^{25}$ is divisible by 20.
- Use binomial theorem to find the remainder when 5^{103} is divided by 13.
- What is the remainder when $17^{17^{17}}$ is divided by 9.
- Using Binomial Theorem, indicate which number is larger $(1.1)^{10000}$ or 1000.
- Show that $9^{n+1} - 8n - 9$ is divisible by 64, whenever n is a positive integer.
- If a and b are distinct integers, prove that $a - b$ is a factor of $a^n - b^n$, whenever n is a positive integer.
- Show that $6^{n+3} - 8n - 6$ is divisible by 6.

I have Learnt

- Describing a mathematical argument and identifying the base case, induction of hypothesis and a precise conclusion.
- Applying the principle of mathematical induction to prove statements, identities, divisibility of numbers and summation formulae.
- Evaluating and justifying conclusions, communicating a position clearly in an appropriate mathematical form in daily life.
- Stating and applying the Binomial Theorem to expand expressions of the form $(a + b)^n$ where n is a positive integer.
- Describing Binomial Theorem as expansion of binomial powers restricted to the set of natural numbers.
- Calculating binomial coefficients using Pascal's triangle.
- Expanding the binomial theorems, and using appropriate techniques to simplify the expression.
- Finding an approximate value using binomial theorem.
- Using binomial theorem to find the remainder when a number to some large exponent is divided by a number.
- Using binomial theorem to find the last digit of a number, testing the divisibility by a number and compare two large numbers.
- Applying concepts of Mathematical induction and binomial theorem to real world problems such as (puzzles, domino effects, Pascal's triangle, Economic forecasting, Rankings, Variable subletting).

Review Exercise

1. Select the correct option:
 - (i) Mathematical induction is used to check a proposition for all n where n is a/an:
(a) real number (b) rational number (c) integer (d) positive integer
 - (ii) A mathematical statement which is true for all positive integers is also true for all:
(a) negative integers (b) positive numbers (c) whole numbers (d) none
 - (iii) If n is even positive integer then the middle term in the expansion of $(a + b)^n$ is:
(a) $\binom{n}{2}^{th}$ term (b) $\binom{n+1}{2}^{th}$ term (c) $\binom{n-1}{2}^{th}$ term (d) $\left(\frac{n}{2} + 1\right)^{th}$ term
 - (iv) In the expansion of $(a + b)^{20}$ a term is at the 11th position. Its position from the end is:
(a) 9th (b) 10th (c) 11th (d) 12th
 - (v) The coefficient of the 3rd last term in the expansion of $(1 + x)^{300}$ is:
(a) 277 (b) 44850 (c) 303 (d) 4305600
 - (vi) $\binom{11}{0} + \binom{11}{2} + \binom{11}{4} + \dots + \binom{11}{10}$ is equal to
(a) 2^{11} (b) 2^{12} (c) 2^{10} (d) $2^{11} - 1$

- (vii) If the third term in the expansion of $(1+x)^p$ is $-\frac{1}{8}x^2$ then the value of p is:
(a) 2 (b) $\frac{1}{2}$ (c) 4 (d) 3
- (viii) The coefficient of x^n in the expansion of $(1+x+x^2+\dots)^{-n}$ where n is an even number:
(a) 1 (b) -1 (c) n (d) $-n+1$
- (ix) The greatest coefficient in the expansion of $(1+x)^{10}$ is:
(a) 2^x (b) $\binom{10}{5}$ (c) $\binom{10}{6}$ (d) 2^{10}
- (x) Binomial series $(2+3x)^{-1/2}$ is valid when:
(a) $|x| \leq 1$ (b) $|x| < 1$ (c) $|x| < \frac{2}{3}$ (d) $|x| < \frac{3}{2}$
2. Using principle of mathematical induction prove that for all positive integers n :
$$\frac{1}{1.2.3} + \frac{1}{2.3.4} + \dots + \frac{1}{n(n+1)(n+2)} = \frac{n(n+3)}{4(n+1)(n+2)}$$
3. The ratio of coefficients of three consecutive terms in the binomial expansion of $(1+x)^n$ is $2 : 15 : 70$. Find the average of the three coefficients.
4. Show that the expansion of $(x^2 + \frac{1}{x})^{12}$ does not contain any term involving $\frac{1}{x}$.
5. If α and β are nearly equal then show that $(\frac{3\beta}{5\alpha-2\beta})^{-1/3} \approx \frac{\alpha}{\alpha+2\beta} + \frac{\alpha+\beta}{3\beta}$
6. If ${}^{22}C_r$ is the largest coefficient in the expansion of $(1+x)^{22}$ then find ${}^{13}C_r$.
7. Use binomial theorem to prove that $6^n - 5^n$ leaves a remainder 1, when divided by 5.

UNIT
08

FUNDAMENTALS OF TRIGONOMETRY

After studying this unit, students will be able to:

- ❖ Use distance formula to establish fundamental law of trigonometry:
 - $\cos(\alpha - \beta) = \cos \alpha \cos \beta + \sin \alpha \sin \beta$, and deduce that
 - $\cos(\alpha + \beta) = \cos \alpha \cos \beta - \sin \alpha \sin \beta$,
 - $\sin(\alpha \pm \beta) = \sin \alpha \cos \beta \pm \cos \alpha \sin \beta$,
 - $\tan(\alpha \pm \beta) = \frac{\tan \alpha \pm \tan \beta}{1 \mp \tan \alpha \tan \beta}$
- ❖ Define allied angles and use fundamental law and its deductions to derive trigonometric ratios of allied angles.
- ❖ Express $a \sin \theta + b \cos \theta$ in the form $r \sin(\theta + \phi)$ where $a = r \cos \phi$ and $b = r \sin \phi$.
- ❖ Derive double angle, half angle and triple angle identities from fundamental law and its deductions.
- ❖ Express the product (of sines and cosines) as sums or differences (of sines and cosines).
- ❖ Express the sums or differences (of sines and cosines) as products (of sines and cosines).



Trigonometry has a wide range of applications in the sciences, such as, in the measurement of distances between celestial bodies or in satellite navigation systems.

The solar system has fascinated human beings everywhere since the start of civilization. We use trigonometry to find heights of high buildings, trees and mountains etc. and distance of the shore from a point in the sea. Astronomers use trigonometry to calculate how far stars and planets are from Earth. Even though, we know the distances between planets and stars.

8.1 Distance Formula

The formula for the distance between two points whose coordinates are (x_1, y_1) and (x_2, y_2) is:

$$d = AB = \sqrt{(x_1 - x_2)^2 + (y_1 - y_2)^2}$$

This is called the distance formula.

For example, if $A(5, 4)$ and $B(3, 2)$ are two points in the plane then distance between A and B is:

$$\begin{aligned} AB &= \sqrt{(x_1 - x_2)^2 + (y_1 - y_2)^2} = \sqrt{(5 - 3)^2 + (4 - 2)^2} \\ &= \sqrt{(2)^2 + (2)^2} = \sqrt{8} \text{ units} \end{aligned}$$



8.2 Fundamental Law of Trigonometry

Its law is stated as:

$$\cos(\alpha - \beta) = \cos \alpha \cos \beta + \sin \alpha \sin \beta \text{ where } \alpha > \beta$$

Proof:

Consider a unit circle with centre at O as shown in the figure below. \overline{OC} and \overline{OD} are terminal sides of angles α and β respectively in standard position where $\alpha > \beta$.

The coordinates of points D and C are respectively $(\cos \alpha, \sin \alpha)$ and $(\cos \beta, \sin \beta)$.

Measure of $\angle COD$ is $\alpha - \beta$. An angle $\angle AOB$ equal to measure of $\angle COD = \alpha - \beta$ is constructed in standard position in the same unit circle.

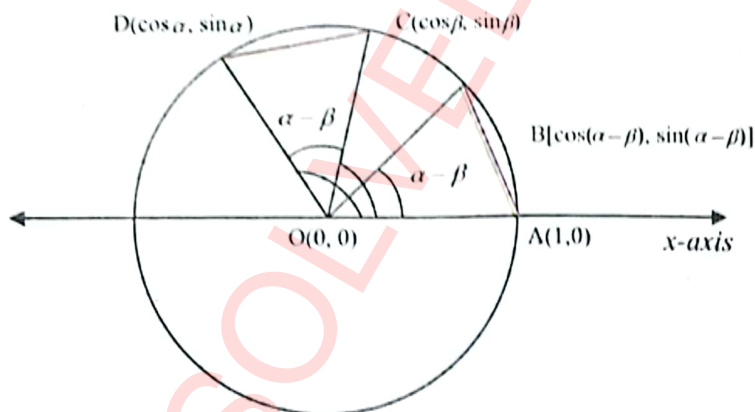

As $\angle COD = \angle AOB = \alpha - \beta$, therefore

$$CD = AB$$

$$\sqrt{(\cos \alpha - \cos \beta)^2 + (\sin \alpha - \sin \beta)^2} = \sqrt{[\cos(\alpha - \beta) - 1]^2 + [\sin(\alpha - \beta) - 0]^2}$$

Taking square on both sides, we have:

$$\begin{aligned} (\cos \alpha - \cos \beta)^2 + (\sin \alpha - \sin \beta)^2 &= [\cos(\alpha - \beta) - 1]^2 + [\sin(\alpha - \beta) - 0]^2 \\ \Rightarrow \cos^2 \alpha + \cos^2 \beta - 2 \cos \alpha \cos \beta + \sin^2 \alpha + \sin^2 \beta - 2 \sin \alpha \sin \beta \\ &= \cos^2(\alpha - \beta) + 1 - 2 \cos(\alpha - \beta) + \sin^2(\alpha - \beta) \end{aligned}$$

$$\begin{aligned} &\Rightarrow \cos^2 \alpha + \sin^2 \alpha + \cos^2 \beta + \sin^2 \beta - 2 \cos \alpha \cos \beta - 2 \sin \alpha \sin \beta \\ &= \cos^2(\alpha - \beta) + \sin^2(\alpha - \beta) + 1 - 2 \cos(\alpha - \beta) \quad \dots\dots \text{(Rearranging)} \\ &\Rightarrow 1 + 1 - 2 \cos \alpha \cos \beta - 2 \sin \alpha \sin \beta = 1 + 1 - 2 \cos(\alpha - \beta) \quad \dots\dots \text{(as } \cos^2 \theta + \sin^2 \theta = 1) \\ &\Rightarrow -2 \cos \alpha \cos \beta - 2 \sin \alpha \sin \beta = -2 \cos(\alpha - \beta) \end{aligned}$$

After simplification, we get

$$\cos(\alpha - \beta) = \cos \alpha \cos \beta + \sin \alpha \sin \beta \quad \dots\dots\dots (1)$$

This law is known as fundamental law of trigonometry.

Does the identity (1) make it possible to find

$\cos(90^\circ - 60^\circ) = ?$ Let us check.

$$\cos(90^\circ - 60^\circ) = \cos 90^\circ \cos 60^\circ + \sin 90^\circ \sin 60^\circ$$

$$\cos 30^\circ = 0 \times 0.5 + 1 \times 0.866$$

$$0.866 = 0.866 \text{ which is true.}$$

Now replacing β by $-\beta$ in the above law, we get:

$$\cos(\alpha + \beta) = \cos \alpha \cos(-\beta) + \sin \alpha \sin(-\beta)$$

$$\cos(\alpha + \beta) = \cos \alpha \cos \beta - \sin \alpha \sin \beta \quad \dots\dots\dots (2)$$

Before proving the other identities, we deduce some important results from the fundamental law.

(i) Letting $\alpha = 0$ in the fundamental law, we get:

$$\cos(0 - \beta) = \cos 0 \cos \beta + \sin 0 \sin \beta$$

$$\Rightarrow \cos(-\beta) = 1 \times \cos \beta + 0 \times \sin \beta$$

$$\cos(-\beta) = \cos \beta$$

(ii) Substituting $\alpha = \frac{\pi}{2}$ in the fundamental law, we have:

$$\cos\left(\frac{\pi}{2} - \beta\right) = \cos \frac{\pi}{2} \cos \beta + \sin \frac{\pi}{2} \sin \beta$$

$$\Rightarrow \cos\left(\frac{\pi}{2} - \beta\right) = 0 \times \cos \beta + 1 \times \sin \beta$$

$$\cos\left(\frac{\pi}{2} - \beta\right) = \sin \beta$$

(iii) Now substituting $\beta = -\frac{\pi}{2}$ in the fundamental law, we have:

$$\cos\left(\alpha - \left(-\frac{\pi}{2}\right)\right) = \cos \alpha \cos\left(-\frac{\pi}{2}\right) + \sin \alpha \sin\left(-\frac{\pi}{2}\right)$$

$$\Rightarrow \cos\left(\alpha + \frac{\pi}{2}\right) = \cos \alpha \times 0 + \sin \alpha \times (-1)$$

$$\cos\left(\frac{\pi}{2} + \alpha\right) = -\sin \alpha$$

Key Facts



Trigonometric identities are used in simplifying complicated problems in various fields such as calculus, physical and social sciences.



Check Point

- Are the equations $\sin \alpha = \cos(90^\circ - \alpha)$ and $\cos \alpha = \sin(90^\circ - \alpha)$ true for all real numbers or only for values of α in the interval $0 < \alpha < 90^\circ$?
- Amna said that, without finding the values on a calculator, she knows that $\sin 100^\circ = \cos(-10^\circ)$. Do you agree with her? Explain why or why not.

(iv) Replacing β with $\frac{\pi}{2} + \alpha$, the identity $\cos\left(\frac{\pi}{2} - \beta\right) = \sin \beta$ gives:

$$\cos\left(\frac{\pi}{2} - \left(\frac{\pi}{2} + \alpha\right)\right) = \sin\left(\frac{\pi}{2} + \alpha\right)$$

$$\Rightarrow \cos(-\alpha) = \sin\left(\frac{\pi}{2} + \alpha\right)$$

$$\sin\left(\frac{\pi}{2} + \alpha\right) = \cos \alpha$$

(v) Replacing α with $\frac{\pi}{2} + \alpha$, the identity (2) gives:

$$\cos\left(\frac{\pi}{2} + \alpha + \beta\right) = \cos\left(\frac{\pi}{2} + \alpha\right)\cos \beta - \sin\left(\frac{\pi}{2} + \alpha\right)\sin \beta$$

$$\Rightarrow \cos\left(\frac{\pi}{2} + (\alpha + \beta)\right) = \cos\left(\frac{\pi}{2} + \alpha\right)\cos \beta - \sin\left(\frac{\pi}{2} + \alpha\right)\sin \beta$$

$$\sin(\alpha + \beta) = \sin \alpha \cos \beta + \cos \alpha \sin \beta \quad \dots\dots\dots (3)$$

Now replacing β by $-\beta$ in identity (3), we get:

$$\sin(\alpha + (-\beta)) = \sin \alpha \cos(-\beta) + \cos \alpha \sin(-\beta)$$

$$\sin(\alpha - \beta) = \sin \alpha \cos \beta - \cos \alpha \sin \beta \quad \dots\dots\dots (4)$$

Example: Prove that:

$$\tan(\alpha + \beta) = \frac{\tan \alpha + \tan \beta}{1 - \tan \alpha \tan \beta}$$

Solution:

$$\tan(\alpha + \beta) = \frac{\sin(\alpha + \beta)}{\cos(\alpha + \beta)}$$

$$\frac{\sin \alpha \cos \beta + \cos \alpha \sin \beta}{\cos \alpha \cos \beta - \sin \alpha \sin \beta}$$

Dividing numerator and denominator by $\cos \alpha \cos \beta$, we get:

$$\frac{\frac{\sin \alpha \cos \beta + \cos \alpha \sin \beta}{\cos \alpha \cos \beta}}{\frac{\cos \alpha \cos \beta - \sin \alpha \sin \beta}{\cos \alpha \cos \beta}} = \frac{\frac{\sin \alpha \cos \beta}{\cos \alpha \cos \beta} + \frac{\cos \alpha \sin \beta}{\cos \alpha \cos \beta}}{\frac{\cos \alpha \cos \beta}{\cos \alpha \cos \beta} - \frac{\sin \alpha \sin \beta}{\cos \alpha \cos \beta}}$$

$$= \frac{\frac{\sin \alpha}{\cos \alpha} + \frac{\sin \beta}{\cos \beta}}{1 - \frac{\sin \alpha \times \sin \beta}{\cos \alpha \times \cos \beta}} = \frac{\tan \alpha + \tan \beta}{1 - \tan \alpha \tan \beta}$$

$$\therefore \tan(\alpha + \beta) = \frac{\tan \alpha + \tan \beta}{1 - \tan \alpha \tan \beta}$$

Check Point

Prove that:

(i) $\sin(-\alpha) = -\sin \alpha$

(ii) $\tan(-\alpha) = -\tan \alpha$

(iii) $\tan(\alpha - \beta) = \frac{\tan \alpha - \tan \beta}{1 + \tan \alpha \tan \beta}$

Key Facts

The identities of tangent ratio are true for all values of α and β for which $\cos \alpha \neq 0$ and $\cos \beta \neq 0$, and for which $\tan(\alpha + \beta)$ or $\tan(\alpha - \beta)$ are defined.



8.3 Trigonometric Ratios of Allied Angles

The angles connected with basic angles of measure θ by a right angle or its multiple, are called allied angles.

If θ is a basic angle, then angles of measure $\frac{\pi}{2} \pm \theta, \pi \pm \theta, \frac{3\pi}{2} \pm \theta, 2\pi \pm \theta$ etc. are called allied angles.

The following trigonometric ratios can be derived easily with the help of fundamental theorem of trigonometry and its deductions.

| | | |
|---|--|--|
| $\sin\left(\frac{\pi}{2} - \theta\right) = \cos \theta$ | $\sin\left(\frac{\pi}{2} + \theta\right) = \cos \theta$ | $\sin(\pi \mp \theta) = \pm \sin \theta$ |
| $\cos\left(\frac{\pi}{2} - \theta\right) = \sin \theta$ | $\cos\left(\frac{\pi}{2} + \theta\right) = -\sin \theta$ | $\cos(\pi \pm \theta) = -\cos \theta$ |
| $\tan\left(\frac{\pi}{2} - \theta\right) = \cot \theta$ | $\tan\left(\frac{\pi}{2} + \theta\right) = -\cot \theta$ | $\tan(\pi \pm \theta) = \pm \tan \theta$ |
| $\sin\left(\frac{3\pi}{2} \pm \theta\right) = -\cos \theta$ | $\cos\left(\frac{3\pi}{2} \pm \theta\right) = \pm \sin \theta$ | $\tan\left(\frac{3\pi}{2} \pm \theta\right) = \mp \cot \theta$ |
| $\sin(2\pi \pm \theta) = \pm \sin \theta$ | $\cos(2\pi \pm \theta) = \cos \theta$ | $\tan(2\pi \pm \theta) = \pm \tan \theta$ |

Key Facts

- 
- (i) A trigonometric ratio changes to its co-ratio when allied angle contains an odd multiple of right angle. For example sine ratio changes to cosine ratio and vice versa.
 - (ii) A trigonometric ratio does not change when allied angle contains an even multiple of right angle.
 - (iii) The sign of ratio will change according the position of terminal arm of angle in the quadrant.
 - (iv) The above results are also valid for the reciprocals of ratios of sine, cosine and tangent.

Example: Use $(60^\circ - 45^\circ) = 15^\circ$ to find the exact value of:

- (i) $\cos 15^\circ$ (ii) $\sin 15^\circ$ (iii) $\tan 15^\circ$

Solution: Letting $\alpha = 60^\circ$ and $\beta = 45^\circ$, we have:

(i) $\cos(\alpha - \beta) = \cos \alpha \cos \beta + \sin \alpha \sin \beta$

$$\cos 15^\circ = \cos(60^\circ - 45^\circ) = \cos 60^\circ \cos 45^\circ + \sin 60^\circ \sin 45^\circ$$

$$\cos 15^\circ = 0.5 \times 0.707 + 0.866 \times 0.707$$

$$\cos 15^\circ = 0.3535 + 0.6123 = 0.966$$

(ii) $\sin(\alpha - \beta) = \sin \alpha \cos \beta - \cos \alpha \sin \beta$

$$\sin 15^\circ = \sin(60^\circ - 45^\circ) = \sin 60^\circ \cos 45^\circ - \cos 60^\circ \sin 45^\circ$$

$$\sin 15^\circ = 0.866 \times 0.707 - 0.5 \times 0.707$$

$$\sin 15^\circ = 0.6123 - 0.3535 = 0.259$$

$$(iii) \tan 15^\circ = \frac{\sin 15^\circ}{\cos 15^\circ} = \frac{0.259}{0.966} = 0.268$$

Example: Given that A and B are second-quadrant angles. If $\sin A = \frac{1}{5}$, and $\sin B = \frac{1}{3}$, find $\cos(A+B)$. In which quadrant does the terminal arm of angle $(A+B)$ lie?

Solution: We use the identity $\cos^2 \theta = 1 - \sin^2 \theta$ to find $\cos A$ and $\cos B$.

$$\cos^2 A = 1 - \sin^2 A$$

$$\cos^2 A = 1 - \left(\frac{1}{5}\right)^2 = 1 - \frac{1}{25} = \frac{24}{25}$$

$$\cos A = -\frac{\sqrt{24}}{5} \quad (\text{Terminal arm of angle is in QII.})$$

Similarly, $\cos^2 B = 1 - \sin^2 B$

$$\cos^2 B = 1 - \left(\frac{1}{3}\right)^2 = 1 - \frac{1}{9} = \frac{8}{9}$$

$$\cos B = -\frac{\sqrt{8}}{3} \quad (\text{Terminal arm of angle is in QII.})$$

Now

$$\cos(A+B) = \cos A \cos B - \sin A \sin B$$

$$\cos(A+B) = \left(-\frac{\sqrt{24}}{5}\right) \times \left(-\frac{\sqrt{8}}{3}\right) - \left(\frac{1}{5}\right) \times \left(\frac{1}{3}\right)$$

$$\cos(A+B) = \frac{\sqrt{192}}{15} - \frac{1}{15} = \frac{8\sqrt{3}-1}{15}$$

As the value of $(A+B)$ is positive, therefore terminal arm of angle lies in fourth quadrant.

Example: If α, β, γ are interior angles of a triangle, then prove that:

$$\cot \beta \cot \gamma + \cot \alpha \cot \gamma + \cot \alpha \cot \beta = 1$$

Solution: Given that $\alpha + \beta + \gamma = 180^\circ$

$$\alpha + \beta = 180^\circ - \gamma$$

$$\cot(\alpha + \beta) = \cot(180^\circ - \gamma)$$

$$\frac{1}{\tan(\alpha + \beta)} = \frac{1}{\tan(180^\circ - \gamma)} \Rightarrow \tan(\alpha + \beta) = \tan(180^\circ - \gamma)$$

$$\Rightarrow \frac{\tan \alpha + \tan \beta}{1 - \tan \alpha \tan \beta} = -\tan \gamma \Rightarrow \tan \alpha + \tan \beta = -\tan \gamma(1 - \tan \alpha \tan \beta)$$

$$\Rightarrow \tan \alpha + \tan \beta = -\tan \gamma + \tan \alpha \tan \beta \tan \gamma \Rightarrow \tan \alpha + \tan \beta + \tan \gamma = \tan \alpha \tan \beta \tan \gamma$$

Check Point

Find the exact value of $\tan y$, when



$$\tan(y - 45^\circ) = \frac{1}{3}$$

Check Point

Find the exact value of



$$(i) \cos 105^\circ \quad (ii) \cos \left(\frac{\pi}{3} - \frac{\pi}{4} \right)$$

Dividing both sides by $\tan \alpha \tan \beta \tan \gamma$.

$$\frac{\tan \alpha}{\tan \alpha \tan \beta \tan \gamma} + \frac{\tan \beta}{\tan \alpha \tan \beta \tan \gamma} + \frac{\tan \gamma}{\tan \alpha \tan \beta \tan \gamma} = \frac{\tan \alpha \tan \beta \tan \gamma}{\tan \alpha \tan \beta \tan \gamma}$$

$$\cot \beta \cot \gamma + \cot \alpha \cot \gamma + \cot \alpha \cot \beta = 1$$

8.4 Expressing $a \sin \theta + b \cos \theta$ in the form $r \sin(\theta + \phi)$

Let $P(a, b)$ be a point in the coordinate plane and let θ be the angle that \overrightarrow{OP} makes with x -axis as shown in the figure.

If we let $a = r \cos \phi$ and $b = r \sin \phi$, then

$$\begin{aligned} a \sin \theta + b \cos \theta &= r \cos \phi \sin \theta + r \sin \phi \cos \theta \\ &= r (\cos \phi \sin \theta + \sin \phi \cos \theta) \\ &= r \sin(\theta + \phi) \end{aligned}$$

Where $r = \sqrt{a^2 + b^2}$ and $\phi = \tan^{-1}\left(\frac{b}{a}\right)$.

For more illustration, let us solve following example.

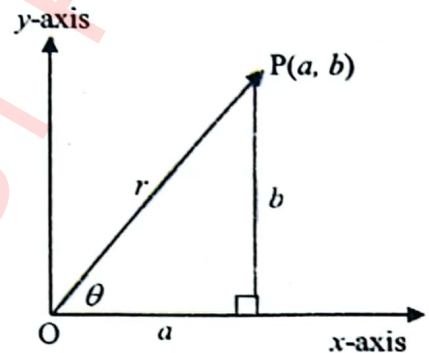

Example:

Express $12 \sin \theta + 5 \cos \theta$ in the form of $r \sin(\theta + \phi)$.

Solution: If we compare $12 \sin \theta + 5 \cos \theta$ with $r \cos \phi \sin \theta + r \sin \phi \cos \theta$, then:

$$a = 12 = r \cos \phi \text{ and } b = 5 = r \sin \phi$$

$$\text{So, } r = \sqrt{a^2 + b^2} = \sqrt{(12)^2 + (5)^2} = \sqrt{169} = 13$$

$$\begin{aligned} \text{Now } 12 \sin \theta + 5 \cos \theta &= 13 \left(\frac{12}{13} \times \sin \theta + \frac{5}{13} \times \cos \theta \right) = 13 \left(\sin \theta \times \frac{12}{13} + \cos \theta \times \frac{5}{13} \right) \\ &= r (\sin \theta \times \cos \phi + \cos \theta \times \sin \phi) = r \sin(\theta + \phi) \end{aligned}$$

$$\text{Where } r = 13 \text{ and } \phi = \tan^{-1}\left(\frac{b}{a}\right) = \tan^{-1}\left(\frac{5}{12}\right).$$

Check Point



Express $\cos \theta + \sin \theta$ in the form of $r \sin(\theta + \phi)$.

Exercise 8.1

- Find the values of $\cos(\alpha \pm \beta)$, $\sin(\alpha \pm \beta)$ and $\tan(\alpha \pm \beta)$ for each given pair of angles.
 - $\alpha = 180^\circ$, $\beta = 60^\circ$
 - $\alpha = 60^\circ$, $\beta = 90^\circ$
 - $\alpha = 180^\circ$, $\beta = 30^\circ$
 - $\alpha = \pi$, $\beta = \frac{2\pi}{3}$
 - $\alpha = \frac{4\pi}{3}$, $\beta = \frac{\pi}{6}$
 - $\alpha = \frac{7\pi}{4}$, $\beta = \frac{3\pi}{4}$
- Find the exact value of $\cos 15^\circ$ by using $\cos(45^\circ - 30^\circ)$.
 - Use the value of $\cos 15^\circ$ found in a to find $\cos 165^\circ$ by using $\cos(180^\circ - 15^\circ)$.
 - Use the value of $\cos 15^\circ$ found in a to find $\cos 345^\circ$ by using $\cos(360^\circ - 15^\circ)$.
 - Use $\cos A = \sin(90^\circ - A)$ to find the exact value of $\sin 75^\circ$ and then find $\tan 75^\circ$.
- Find the exact value of $\cos 120^\circ$ by using $\cos(180^\circ - 60^\circ)$ and $\cos(90^\circ + 30^\circ)$.
 - Find the exact value of $\sin 120^\circ$ and then $\tan 120^\circ$.
 - Find the exact value of $\cos 75^\circ$ by using $\cos(120^\circ - 45^\circ)$.
 - Use the value of $\cos 75^\circ$ found in c to find $\cos 105^\circ$ by using $\cos(180^\circ - 75^\circ)$.
 - Use the value of $\cos 75^\circ$ found in c to find $\cos 285^\circ$ by using $\cos(360^\circ - 75^\circ)$.
 - Find the exact value of $\sin 15^\circ$.
- Rewrite as a single expression.
 - $\cos 6\theta \cos 3\theta - \sin 6\theta \sin 3\theta$
 - $\cos 7\theta \cos 2\theta + \sin 7\theta \sin 2\theta$
 - $\sin\left(\frac{\theta}{3}\right)\cos\left(\frac{\theta}{6}\right) + \cos\left(\frac{\theta}{3}\right)\sin\left(\frac{\theta}{6}\right)$
 - $\sin 138^\circ \cos 46^\circ - \cos 138^\circ \sin 46^\circ$
 - $\frac{\tan 75^\circ - \tan 45^\circ}{1 + \tan 75^\circ \tan 45^\circ}$
 - $\frac{\tan \frac{4\pi}{3} + \tan \frac{2\pi}{3}}{1 - \tan \frac{4\pi}{3} \tan \frac{2\pi}{3}}$
- For $\sin \alpha = \frac{4}{5}$, $\tan \beta = -\frac{5}{12}$ with terminal side of α in QII, find $\cos(\alpha + \beta)$ and $\cos(\alpha - \beta)$.
- For $\cos \alpha = -\frac{7}{25}$ with terminal side of α in QII and $\cot \beta = \frac{15}{8}$ with terminal side of β in QIII, find:
 - $\sin(\alpha - \beta)$
 - $\cos(\alpha - \beta)$
 - $\tan(\alpha - \beta)$
- Given α and β are acute angles with $\sin \alpha = \frac{12}{13}$ and $\tan \beta = \frac{4}{3}$ find:
 - $\sin(\alpha + \beta)$
 - $\cos(\alpha + \beta)$
 - $\tan(\alpha + \beta)$
- If $\sin \alpha = \frac{3}{5}$, where $0 < \alpha < \frac{\pi}{2}$ and $\cos \beta = \frac{12}{13}$, where $\frac{3\pi}{2} < \beta < 2\pi$ find:
 - $\csc(\alpha + \beta)$
 - $\sec(\alpha + \beta)$
 - $\cot(\alpha + \beta)$
- Given α and β are obtuse angles with $\sin \alpha = \frac{1}{\sqrt{2}}$ and $\cos \beta = -\frac{3}{5}$ find:
 - $\sin(\alpha \pm \beta)$
 - $\cos(\alpha \pm \beta)$
 - $\tan(\alpha \pm \beta)$

10. Verify:

(i) $\sin\left(\frac{\pi}{2} - \alpha\right) = \cos \alpha$

(ii) $\cos(\pi - \alpha) = -\cos \alpha$

(iii) $\cos\left(\alpha + \frac{\pi}{4}\right) = \frac{1}{\sqrt{2}}(\cos \alpha - \sin \alpha)$ (iv) $\sin\left(\beta + \frac{\pi}{4}\right) = \frac{\sqrt{2}}{2}(\cos \beta + \sin \beta)$

(v) $\tan\left(\gamma - \frac{\pi}{4}\right) = \frac{\tan \gamma - 1}{\tan \gamma + 1}$ (vi) $\tan\left(\gamma + \frac{\pi}{4}\right) = \frac{1 + \tan \gamma}{1 - \tan \gamma} = \frac{\cos \gamma + \sin \gamma}{\cos \gamma - \sin \gamma}$

(vii) $\cos(x+y) + \cos(x-y) = 2\cos x \cos y$ (viii) $\sin(x+y) - \sin(x-y) = 2\cos x \sin y$

11. Show that:

(i) $\frac{\sin(180^\circ + \lambda)\cos(270^\circ + \lambda)}{\sin(180^\circ - \lambda)\cos(270^\circ - \lambda)} = 1$ (ii) $\frac{\sin(90^\circ + \alpha) - \cos(360^\circ - \alpha) + \cos \alpha}{\sin(180^\circ - \alpha) + \sin(270^\circ - \alpha) + \cos(90^\circ + \alpha)} = -1$

(iii) $\tan \alpha + \tan \beta = \frac{\sin(\alpha + \beta)}{\cos \alpha \cos \beta}$

(iv) $\sin(\alpha + \beta)\sin(\alpha - \beta) = \cos^2 \beta - \cos^2 \alpha = \sin^2 \alpha - \sin^2 \beta$

(v) $\frac{\tan(x+y)}{\cot(x-y)} = \frac{\tan^2 x - \tan^2 y}{1 - \tan^2 x \tan^2 y}$ (vi) $\frac{\cos(\alpha + \beta)}{\cos(\alpha - \beta)} = \frac{1 - \tan \alpha \tan \beta}{1 + \tan \alpha \tan \beta}$

(vii) $\cot(\alpha - \beta) = \frac{\cot \alpha \cot \beta + 1}{\cot \beta - \cot \alpha}$ (viii) $\frac{\cos 4\theta}{\csc \theta} + \frac{\sin 4\theta}{\sec \theta} = \sin 5\theta$

12. If $\alpha + \beta + \gamma = 180^\circ$, prove that:

(i) $\tan \alpha + \tan \beta + \tan \gamma = \tan \alpha \tan \beta \tan \gamma$ (ii) $\cot \frac{\alpha}{2} + \cot \frac{\beta}{2} + \cot \frac{\gamma}{2} = \cot \frac{\alpha}{2} \cot \frac{\beta}{2} \cot \frac{\gamma}{2}$

(iii) $\tan \frac{\alpha}{2} \tan \frac{\beta}{2} + \tan \frac{\beta}{2} \tan \frac{\gamma}{2} + \tan \frac{\gamma}{2} \tan \frac{\alpha}{2} + 1 = 0$

13. Express the following in the form of $r \sin(\theta + \phi)$.

(i) $12\sin \theta - 5\cos \theta$ (ii) $3\sin \theta + 4\cos \theta$ (iii) $\sin \theta - \cos \theta$

14. A telephone pole is braced by two wires that are both fastened to the ground at a point $3m$ from the base of the pole. The shorter wire is fastened to the pole $3m$ above the ground and the longer wire $7m$ above the ground.

- What is the measure, in degrees, of the angle that the shorter wire makes with the ground?
- Let θ be the measure of the angle that the longer wire makes with the ground. Find $\sin \theta$ and $\cos \theta$.
- Find the cosine of the angle between the wires where they meet at the ground.
- Find, to the nearest degree, the measure of the angle between the wires.

8.5 Double, Half and Triple Angle Identities

(i) Double Angle Identities

The double-angle identities for sine, cosine, and tangent can be derived by putting $\alpha = \beta$ in the following identities.

$$\sin(\alpha + \beta) = \sin \alpha \cos \beta + \cos \alpha \sin \beta \dots (1)$$

$$\cos(\alpha + \beta) = \cos \alpha \cos \beta - \sin \alpha \sin \beta \dots (2)$$

$$\tan(\alpha + \beta) = \frac{\tan \alpha + \tan \beta}{1 - \tan \alpha \tan \beta} \dots (3)$$

Putting $\beta = \alpha$ in identity (1), we get:

$$\sin(\alpha + \alpha) = \sin \alpha \cos \alpha + \cos \alpha \sin \alpha$$

$$\sin(2\alpha) = 2\sin \alpha \cos \alpha \dots (A)$$

Now putting $\beta = \alpha$ in identity (2), we get:

$$\cos(\alpha + \alpha) = \cos \alpha \cos \alpha - \sin \alpha \sin \alpha$$

$$\cos(2\alpha) = \cos^2 \alpha - \sin^2 \alpha \dots (B)$$

Using relation $\cos^2 \alpha + \sin^2 \alpha = 1$, the identity (B) becomes:

$$\cos(2\alpha) = 2\cos^2 \alpha - 1 \dots (C)$$

$$\cos(2\alpha) = 1 - 2\sin^2 \alpha \dots (D)$$

Relations (C) and (D) also imply:

$$\cos^2 \alpha = \frac{1 + \cos 2\alpha}{2} \Rightarrow \cos \alpha = \pm \sqrt{\frac{1 + \cos 2\alpha}{2}} \dots (E)$$

$$\sin^2 \alpha = \frac{1 - \cos 2\alpha}{2} \Rightarrow \sin \alpha = \pm \sqrt{\frac{1 - \cos 2\alpha}{2}} \dots (F)$$

Dividing identity (F) by (E), we have:

$$\tan^2 \alpha = \frac{1 - \cos 2\alpha}{1 + \cos 2\alpha} \dots (G)$$

Again putting $\beta = \alpha$ in identity (3), we get:

$$\tan(\alpha + \alpha) = \frac{\tan \alpha + \tan \alpha}{1 - \tan \alpha \tan \alpha}$$

$$\tan(2\alpha) = \frac{2 \tan \alpha}{1 - \tan^2 \alpha} \dots (H)$$

Check Point



Does $\cos 2\theta = \sin 2(90^\circ - \theta)$?

Justify your answer.

Check Point



Use the double angle formula to find the exact value of $\sin 120^\circ$.

(ii) Half Angle Identities

Substituting $\alpha = \frac{\theta}{2}$ in above identities, we get the following relations.

From identity (A), we get:

$$\sin\left(2 \times \frac{\theta}{2}\right) = 2 \sin\left(\frac{\theta}{2}\right) \cos\left(\frac{\theta}{2}\right) \Rightarrow \sin(\theta) = 2 \sin\left(\frac{\theta}{2}\right) \cos\left(\frac{\theta}{2}\right) \dots\dots\dots(I)$$

Similarly, identities (B) to (D) imply:

$$\cos(\theta) = \cos^2\left(\frac{\theta}{2}\right) - \sin^2\left(\frac{\theta}{2}\right) = 2 \cos^2\left(\frac{\theta}{2}\right) - 1 = 1 - 2 \sin^2\left(\frac{\theta}{2}\right) \dots\dots\dots(J)$$

And from identity (H):

$$\tan\left(2 \times \frac{\theta}{2}\right) = \frac{2 \tan\left(\frac{\theta}{2}\right)}{1 - \tan^2\left(\frac{\theta}{2}\right)} \Rightarrow \tan(\theta) = \frac{2 \tan\left(\frac{\theta}{2}\right)}{1 - \tan^2\left(\frac{\theta}{2}\right)} \dots\dots\dots(K)$$

From identities (E) and (F), we have:

$$\cos\left(\frac{\theta}{2}\right) = \pm \sqrt{\frac{1 + \cos \theta}{2}} \dots\dots\dots(L)$$

$$\sin\left(\frac{\theta}{2}\right) = \pm \sqrt{\frac{1 - \cos \theta}{2}} \dots\dots\dots(M)$$

Now dividing identity (M) by (L), we have:

$$\tan\left(\frac{\theta}{2}\right) = \pm \sqrt{\frac{1 - \cos \theta}{1 + \cos \theta}} \dots\dots\dots(N)$$

These identities are useful in simplifying complex trigonometric expressions.

(iii) Triple Angle Identities

$\sin 3\alpha$, $\cos 3\alpha$ and $\tan 3\alpha$ etc. are called triple angle identities. Let's prove these identities.

$$\begin{aligned} (a) \sin(3\alpha) &= \sin(2\alpha + \alpha) = \sin(2\alpha)\cos\alpha + \cos(2\alpha)\sin\alpha \\ &= (2\sin\alpha\cos\alpha)\cos\alpha + (1 - 2\sin^2\alpha)\sin\alpha \dots \text{by (A) and (D)}. \\ &= 2\sin\alpha\cos^2\alpha + \sin\alpha - 2\sin^3\alpha \\ &= 2\sin\alpha(1 - \sin^2\alpha) + \sin\alpha - 2\sin^3\alpha \dots (\because \sin^2\alpha + \cos^2\alpha = 1) \\ &= 2\sin\alpha - 2\sin^3\alpha + \sin\alpha - 2\sin^3\alpha \\ \sin(3\alpha) &= 3\sin\alpha - 4\sin^3\alpha \end{aligned}$$

$$\begin{aligned}
 (b) \cos(3\alpha) &= \cos(2\alpha + \alpha) = \cos(2\alpha)\cos\alpha - \sin(2\alpha)\sin\alpha \\
 &= (2\cos^2\alpha - 1)\cos\alpha - (2\sin\alpha\cos\alpha)\sin\alpha \quad \dots \text{by (A) and (C).} \\
 &= 2\cos^3\alpha - \cos\alpha - 2\sin^2\alpha\cos\alpha \\
 &= 2\cos^3\alpha - \cos\alpha - 2(1 - \cos^2\alpha)\cos\alpha \quad \dots (\because \sin^2\alpha + \cos^2\alpha = 1) \\
 &= 2\cos^3\alpha - \cos\alpha - 2\cos\alpha + 2\cos^3\alpha
 \end{aligned}$$

$$\cos(3\alpha) = 4\cos^3\alpha - 3\cos\alpha$$

$$(c) \tan(3\alpha) = \tan(2\alpha + \alpha)$$

$$\begin{aligned}
 &= \frac{\tan(2\alpha) + \tan\alpha}{1 - \tan(2\alpha)\tan\alpha} = \frac{\frac{2\tan\alpha}{1 - \tan^2\alpha} + \tan\alpha}{1 - \left(\frac{2\tan\alpha}{1 - \tan^2\alpha}\right)\tan\alpha} \quad \dots \text{by (H)}
 \end{aligned}$$

$$\begin{aligned}
 &= \frac{\frac{2\tan\alpha + \tan\alpha(1 - \tan^2\alpha)}{1 - \tan^2\alpha}}{\frac{1 - \tan^2\alpha - 2\tan^2\alpha}{1 - \tan^2\alpha}} = \frac{2\tan\alpha + \tan\alpha - \tan^3\alpha}{1 - 3\tan^2\alpha}
 \end{aligned}$$

$$\tan(3\alpha) = \frac{3\tan\alpha - \tan^3\alpha}{1 - 3\tan^2\alpha}$$

Example: Given $\sin\theta = \frac{3}{5}$, find the values of $\sin 2\theta$, $\cos 2\theta$ and $\tan 2\theta$.

Solution: First we find the value of $\cos\theta$.

$$\cos^2\theta = 1 - \sin^2\theta \Rightarrow \cos^2\theta = 1 - \left(\frac{3}{5}\right)^2 = \frac{16}{25}$$

$$\cos\theta = \frac{4}{5}$$

Now (i) $\sin 2\theta = 2\sin\theta\cos\theta$

$$\sin 2\theta = 2 \times \frac{3}{5} \times \frac{4}{5} = \frac{24}{25}$$

(ii) $\cos 2\theta = 1 - 2 \times \sin^2\theta$

$$\cos 2\theta = 1 - 2 \times \left(\frac{3}{5}\right)^2 = 1 - \frac{18}{25} = \frac{7}{25}$$

Check Point

Find $\sin\left(\frac{\theta}{2}\right)$ when

$$\cos\theta = -\frac{3}{5} \text{ where } \frac{\pi}{2} < \theta < \pi.$$

$$(iii) \tan 2\theta = \frac{\sin 2\theta}{\cos 2\theta} = \frac{24/25}{7/25} = \frac{24}{7}$$

Example: Use the half-angle identities to find exact values for: (a) $\sin 15^\circ$ (b) $\tan 15^\circ$

$$\begin{aligned} \text{Solution: (a) } \sin 15^\circ &= \sin\left(\frac{30^\circ}{2}\right) = \sqrt{\frac{1 - \cos 30^\circ}{2}} = \sqrt{\frac{1 - 0.866}{2}} \\ &= \sqrt{\frac{0.134}{2}} = \sqrt{0.067} = 0.259 \end{aligned}$$

$$\begin{aligned} \text{(b) } \tan 15^\circ &= \tan\left(\frac{30^\circ}{2}\right) = \frac{1 - \cos 30^\circ}{\sin 30^\circ} = \frac{1 - 0.866}{0.5} \\ &= \frac{0.134}{0.5} = 0.268 \end{aligned}$$

Example: For $\cos \alpha = \frac{-7}{25}$ and α in QIII, find values of $\sin\left(\frac{\alpha}{2}\right)$ and $\cos\left(\frac{\alpha}{2}\right)$.

Solution: When $\pi < \alpha < \frac{3\pi}{2}$ then $\frac{\pi}{2} < \frac{\alpha}{2} < \frac{3\pi}{4}$. Thus, $\sin\left(\frac{\alpha}{2}\right) > 0$ and $\cos\left(\frac{\alpha}{2}\right) < 0$.

$$\sin\left(\frac{\alpha}{2}\right) = \sqrt{\frac{1 - \cos \theta}{2}} = \sqrt{\frac{1 - \left(\frac{-7}{25}\right)}{2}} = \sqrt{\frac{16}{25}} = \frac{4}{5}$$

$$\cos\left(\frac{\alpha}{2}\right) = -\sqrt{\frac{1 + \cos \theta}{2}} = -\sqrt{\frac{1 + \left(\frac{-7}{25}\right)}{2}} = -\sqrt{\frac{9}{25}} = -\frac{3}{5}$$

Example: Express $4\sin^4 x$ in terms of an expression containing only cosines to the power 1.

$$\begin{aligned} \text{Solution: } 4\sin^4 x &= 4(\sin^2 x)^2 = 4\left(\frac{1 - \cos 2x}{2}\right)^2 \\ &= 4\left(\frac{1 - 2\cos 2x + \cos^2(2x)}{4}\right) = 1 - 2\cos 2x + \frac{1 + \cos 4x}{2} \\ &= \frac{2 - 4\cos 2x + 1 + \cos 4x}{2} = \frac{3 - 4\cos 2x + \cos 4x}{2} \end{aligned}$$

Example: Find the exact value of $\sin 22.5^\circ \times \cos 22.5^\circ$.

Solution: As $\sin(2\alpha) = 2\sin \alpha \cos \alpha$

$$\therefore \sin \alpha \cos \alpha = \frac{\sin(2\alpha)}{2}$$

Check Point

Verify
 $(\sin \theta - \cos \theta)^2 = 1 - \sin 2\theta$

Substituting the value of angle, we get:

$$\begin{aligned} \sin 22.5^\circ \times \cos 22.5^\circ &= \frac{\sin(2 \times 22.5^\circ)}{2} \\ &= \frac{\sin(2 \times 22.5^\circ)}{2} = \frac{\sin 45^\circ}{2} = 0.345 \end{aligned}$$

Example: Prove that: $\tan\left(\frac{\theta}{2}\right) = \pm\left(\frac{1 - \cos\theta}{\sin\theta}\right)$

Solution: We know that:

$$\begin{aligned} \tan\left(\frac{\theta}{2}\right) &= \pm\sqrt{\frac{1 - \cos\theta}{1 + \cos\theta}} = \pm\sqrt{\frac{(1 - \cos\theta)(1 - \cos\theta)}{(1 + \cos\theta)(1 - \cos\theta)}} \\ &= \pm\sqrt{\frac{(1 - \cos\theta)^2}{1 - \cos^2\theta}} = \pm\sqrt{\frac{(1 - \cos\theta)^2}{\sin^2\theta}} = \pm\left(\frac{1 - \cos\theta}{\sin\theta}\right) \end{aligned}$$

Example: Prove that: $\frac{\sin\theta \cos\theta}{0.5 \cos 2\theta} = \tan 2\theta$

Solution: L.H.S = $\frac{\sin\theta \cos\theta}{0.5 \cos 2\theta} = \frac{2 \times \sin\theta \cos\theta}{2 \times 0.5 \cos 2\theta}$
 $= \frac{\sin 2\theta}{\cos 2\theta} = \tan 2\theta = \text{R.H.S}$

Exercise 8.2

- Suppose P (-3, 4) lies on the terminal side of θ when θ is plotted in standard position. Find $\cos 2\theta$ and $\sin 2\theta$ and determine the quadrant in which the terminal side of the angle 2θ lies when it is plotted in standard position.
- If $\sin \alpha = y$ and α lies in QII. Find expressions for $\sin 2\alpha$, $\cos 2\alpha$ and $\tan 2\alpha$ in terms of y .
- Use a half angle formula to find the exact value of $\cos 15^\circ$.
- Find (a) $\sin 2\theta$ (b) $\cos 2\theta$ (c) $\tan 2\theta$ (d) $\sin \frac{\theta}{2}$ (e) $\cos \frac{\theta}{2}$ (f) $\tan \frac{\theta}{2}$ when:

| | |
|---|--|
| (i) $\cos\theta = \frac{3}{5}$ where $0 < \theta < \frac{\pi}{2}$ | (ii) $\tan\theta = \frac{12}{5}$ where $\pi < \theta < \frac{3\pi}{2}$ |
| (iii) $\sin\theta = -\frac{7}{25}$ where $\frac{3\pi}{2} < \theta < 2\pi$ | (iv) $\sec\theta = \sqrt{5}$ where $\frac{3\pi}{2} < \theta < 2\pi$ |
| (v) $\csc\theta = 4$ where $\frac{\pi}{2} < \theta < \pi$ | (vi) $\cot\theta = -\frac{1}{2}$ where $\frac{\pi}{2} < \theta < \pi$ |

5. Find exact values for $\sin \theta$, $\cos \theta$ and $\tan \theta$ using the information given.

(i) $\sin 2\theta = \frac{24}{25}$, 2θ in QII (ii) $\cos 2\theta = -\frac{7}{25}$, 2θ in QIII

(iii) $\sin 2\theta = -\frac{240}{289}$, 2θ in QIII (iv) $\cos 2\theta = \frac{120}{169}$, 2θ in QIV

6. Use a double-angle identity to find exact values for the following expressions.

(i) $\sin 15^\circ \cos 15^\circ$ (ii) $\cos^2 15^\circ - \sin^2 15^\circ$ (iii) $1 - 2\sin^2\left(\frac{\pi}{8}\right)$

(iv) $2\cos^2\left(\frac{\pi}{12}\right) - 1$ (v) $\frac{2\tan\left(\frac{\pi}{12}\right)}{1 - \tan^2\left(\frac{\pi}{12}\right)}$

7. Rewrite in terms of an expression containing only cosines to the power 1.

(i) $\sin^2 \alpha \cos^2 \alpha$ (ii) $\sin^4 \alpha \cos^2 \alpha$ (iii) $\sin^4 \alpha \cos^4 \alpha$

8. Verify the following identities.

(i) $(\sin \theta + \cos \theta)^2 = 1 + \sin 2\theta$

(ii) $\tan 2x = \frac{1}{1 - \tan x} - \frac{1}{1 + \tan x}$

(iii) $\tan \frac{\theta}{2} = \frac{\sin \theta}{1 + \cos \theta}$

(iv) $\csc 2\alpha = \frac{\tan \alpha + \cot \alpha}{2}$

(v) $8\sin^4 \theta = 3 + \cos 4\theta - 4\cos 2\theta$

(vi) $\sin 4\theta = 4\sin \theta \cos^3 \theta - 4\sin^3 \theta \cos \theta$

(vii) $\sin 2\theta = 2\cot \theta \sin^2 \theta$

(viii) $\cos^2 2x + 4\sin^2 x \cos^2 x = 1$

(ix) $\cos 4\theta = 8\cos^4 \theta - 8\cos^2 \theta + 1$

(x) $\sec 2x = \frac{\cos x}{\cos x + \sin x} + \frac{\sin x}{\cos x - \sin x}$

(xi) $\cos^4 x - \sin^4 x = \cos 2x$

(xii) $\tan \frac{\beta}{2} + \cot \frac{\beta}{2} = 2\csc \beta$

(xiii) $\csc 2\alpha - \cot 2\alpha = \tan \alpha$

(xiv) $\frac{\cos 3x - \sin 3x}{\cos x - \sin x} = \frac{2 + \sin 2x}{2}$

(xv) $\frac{\sin 3\alpha}{\sin \alpha} - \frac{\cos 3\alpha}{\cos \alpha} = 2$

(xvi) $\frac{1 - \cos^2 \beta}{2 - 2\cos \beta} = \cos^2 \frac{\beta}{2}$

(xvii) $\frac{\sin \theta}{1 + \cos \theta} = \tan \frac{\theta}{2}$

(xviii) $\frac{1 - \tan^2 \frac{x}{2}}{1 + \tan^2 \frac{x}{2}} = \cos x$

(xix) $\frac{\sin 2\alpha}{\sin \alpha} - \frac{\cos 2\alpha}{\cos \alpha} = \sec \alpha$

(xx) $2\sin^2 \frac{\beta}{2} + \cos \beta = 1$

(xxi) $2\cos y \sec 2y = \frac{1}{\cos y - \sin y} + \frac{1}{\cos y + \sin y}$

(xxii) $2\sin y \sec 2y = \frac{1}{\cos y - \sin y} - \frac{1}{\cos y + \sin y}$

8.6 Sum, Difference and Product of Sines and Cosines

8.6.1 Expressing the Product of Sines and Cosines as Sums or Differences

We have proved the following identities:

$$\sin(\alpha + \beta) = \sin \alpha \cos \beta + \cos \alpha \sin \beta \quad (1)$$

$$\sin(\alpha - \beta) = \sin \alpha \cos \beta - \cos \alpha \sin \beta \quad (2)$$

$$\cos(\alpha + \beta) = \cos \alpha \cos \beta - \sin \alpha \sin \beta \quad (3)$$

$$\cos(\alpha - \beta) = \cos \alpha \cos \beta + \sin \alpha \sin \beta \quad (4)$$

Addition of identities (1) and (2), and (3) and (4) gives:

$$\sin(\alpha + \beta) + \sin(\alpha - \beta) = 2 \sin \alpha \cos \beta \quad (5)$$

$$\cos(\alpha + \beta) + \cos(\alpha - \beta) = 2 \cos \alpha \cos \beta \quad (6)$$

Subtracting (2) from (1), we get:

$$\sin(\alpha + \beta) - \sin(\alpha - \beta) = 2 \cos \alpha \sin \beta \quad (7)$$

Now, subtracting (4) from (3), we get:

$$\cos(\alpha + \beta) - \cos(\alpha - \beta) = -2 \sin \alpha \sin \beta \quad (8)$$

Identities (5) to (8) can be re-written as:

$$\begin{aligned} 2 \sin \alpha \cos \beta &= \sin(\alpha + \beta) + \sin(\alpha - \beta) \\ 2 \cos \alpha \sin \beta &= \sin(\alpha + \beta) - \sin(\alpha - \beta) \\ 2 \cos \alpha \cos \beta &= \cos(\alpha + \beta) + \cos(\alpha - \beta) \\ -2 \sin \alpha \sin \beta &= \cos(\alpha + \beta) - \cos(\alpha - \beta) \end{aligned}$$

The identities (A) to (D) are known as product to sum formulae.

Example: Express the product $2 \cos 6\theta \sin 3\theta$ as a sum or difference of sine and cosine.

Solution: Using the identity (B), we can write:

$$\begin{aligned} 2 \cos 6\theta \sin 3\theta &= \sin(6\theta + 3\theta) - \sin(6\theta - 3\theta) \\ &= \sin(9\theta) - \sin(3\theta) \end{aligned}$$

Example: Simplify $\sin 40^\circ \cos 20^\circ + \cos 40^\circ \sin 20^\circ$ after converting into sum or difference of sine and cosine.



Check Point

Express $\sin 60^\circ \cos 30^\circ$ as a sum or difference of sine and cosine and simplify.

Solution: $\sin 40^\circ \cos 20^\circ + \cos 40^\circ \sin 20^\circ = \frac{1}{2}(2 \sin 40^\circ \cos 20^\circ) + \frac{1}{2}(2 \cos 40^\circ \sin 20^\circ)$

$$= \frac{1}{2} \{ \sin(40^\circ + 20^\circ) + \sin(40^\circ - 20^\circ) \} + \frac{1}{2} \{ \sin(40^\circ + 20^\circ) - \sin(40^\circ - 20^\circ) \}$$

$$= \frac{1}{2} \{ \sin 60^\circ + \sin 20^\circ \} + \frac{1}{2} \{ \sin 60^\circ - \sin 20^\circ \} = \frac{1}{2} \{ \sin 60^\circ + \sin 20^\circ + \sin 60^\circ - \sin 20^\circ \}$$

$$= \frac{1}{2} \{ 2 \sin 60^\circ \} = \frac{\sqrt{3}}{2}$$

8.6.2 Expressing the Sums or Differences of Sines and Cosines as Product

Let $\alpha = \frac{p+q}{2}$ and $\beta = \frac{p-q}{2}$, then

$$\alpha + \beta = \frac{p+q}{2} + \frac{p-q}{2} = \frac{2p}{2} = p \text{ and } \alpha - \beta = \frac{p+q}{2} - \frac{p-q}{2} = \frac{2q}{2} = q$$

Substituting values of α and β into identities (5) to (8) of section we get:

$$\sin p + \sin q = 2 \sin \left(\frac{p+q}{2} \right) \cos \left(\frac{p-q}{2} \right)$$

$$\sin p - \sin q = 2 \cos \left(\frac{p+q}{2} \right) \sin \left(\frac{p-q}{2} \right)$$

$$\cos p + \cos q = 2 \cos \left(\frac{p+q}{2} \right) \cos \left(\frac{p-q}{2} \right)$$

$$\cos p - \cos q = -2 \sin \left(\frac{p+q}{2} \right) \sin \left(\frac{p-q}{2} \right)$$

Above identities are known as sum to product formulae.

Example: Express $\cos 45^\circ - \cos 15^\circ$ as product.

$$\begin{aligned} \text{Solution: } \cos 45^\circ - \cos 15^\circ &= -2 \sin \left(\frac{45^\circ + 15^\circ}{2} \right) \sin \left(\frac{45^\circ - 15^\circ}{2} \right) \\ &= -2 \sin 30^\circ \sin 15^\circ \end{aligned}$$

Example: Show that $\frac{\sin x + \sin y}{\cos x + \sin y} = \tan \frac{x+y}{2}$

$$\begin{aligned} \text{Solution: } \frac{\sin x + \sin y}{\cos x + \sin y} &= \frac{2 \sin \frac{x+y}{2} \cos \frac{x-y}{2}}{2 \cos \frac{x+y}{2} \cos \frac{x-y}{2}} \\ &= \tan \frac{x+y}{2} \end{aligned}$$



Check Point
Provide two different methods of calculating $\cos 195^\circ \cos 105^\circ$, one of which uses the product to sum. Which method is easier?

Example: Show that: $\cos 6\alpha + \cos 5\alpha + \cos 3\alpha + \cos 2\alpha = 4 \cos(4\alpha) \cos(1.5\alpha) \cos(0.5\alpha)$

$$\begin{aligned} \text{Solution: } \cos 6\alpha + \cos 5\alpha + \cos 3\alpha + \cos 2\alpha &= (\cos 6\alpha + \cos 2\alpha) + (\cos 5\alpha + \cos 3\alpha) \\ &= 2 \cos \frac{6\alpha + 2\alpha}{2} \cos \frac{6\alpha - 2\alpha}{2} + 2 \cos \frac{5\alpha + 3\alpha}{2} \cos \frac{5\alpha - 3\alpha}{2} \\ &= 2 \cos 4\alpha \cos 2\alpha + 2 \cos 4\alpha \cos \alpha = 2 \cos 4\alpha (\cos 2\alpha + \cos \alpha) \\ &= 2 \cos 4\alpha \times 2 \cos \frac{2\alpha + \alpha}{2} \cos \frac{2\alpha - \alpha}{2} = 4 \cos(4\alpha) \cos(1.5\alpha) \cos(0.5\alpha) \end{aligned}$$

Example: Show that: $\sin 70^\circ \sin 30^\circ \cos 20^\circ \cos 10^\circ = \frac{1}{4} \cos 10^\circ + \frac{\sqrt{3}}{16} + \frac{1}{8} \sin 40^\circ$

$$\begin{aligned} \text{Solution: } \sin 70^\circ \sin 30^\circ \cos 20^\circ \cos 10^\circ &= \frac{1}{2} (\sin 70^\circ \cos 20^\circ \cos 10^\circ) \dots \left(\sin 30^\circ = \frac{1}{2} \right) \end{aligned}$$

$$\begin{aligned}
 &= \frac{1}{4}(2\sin 70^\circ \cos 20^\circ)\cos 10^\circ \\
 &= \frac{1}{4}[\sin(70^\circ + 20^\circ) + \sin(70^\circ - 20^\circ)]\cos 10^\circ \\
 &= \frac{1}{4}[\sin 90^\circ + \sin 50^\circ]\cos 10^\circ = \frac{1}{4}[1 + \sin 50^\circ]\cos 10^\circ \\
 &= \frac{1}{4}\cos 10^\circ + \frac{1}{4}\sin 50^\circ \cos 10^\circ = \frac{1}{4}\cos 10^\circ + \frac{1}{8} \times 2\sin 50^\circ \cos 10^\circ \\
 &= \frac{1}{4}\cos 10^\circ + \frac{1}{8}[\sin(50^\circ + 10^\circ) + \sin(50^\circ - 10^\circ)] \\
 &= \frac{1}{4}\cos 10^\circ + \frac{1}{8}[\sin 60^\circ + \sin 40^\circ] = \frac{1}{4}\cos 10^\circ + \frac{1}{8}\left(\frac{\sqrt{3}}{2} + \sin 40^\circ\right) \\
 &= \frac{1}{4}\cos 10^\circ + \frac{\sqrt{3}}{16} + \frac{1}{8}\sin 40^\circ
 \end{aligned}$$

Exercise 8.3

- Use the product-to-sum formula to change the following to sum or difference.

| | | |
|--|---|--|
| (i) $4\sin 16x \cos 10x$ | (ii) $10\cos 10y \cos 6y$ | (iii) $2\cos 5t \sin 3t$ |
| (iv) $6\cos 5x \sin 10x$ | (v) $\sin(-u)\sin 5u$ | (vi) $-2\sin(-100^\circ)\sin(-20^\circ)$ |
| (vii) $\cos 23^\circ \sin 17^\circ$ | (viii) $2\cos 56^\circ \sin 48^\circ$ | (ix) $2\sin 75^\circ \sin 15^\circ$ |
| (x) $4\sin \frac{u+v}{2} \cos \frac{u-v}{2}$ | (xi) $2\cos \frac{2u+2v}{2} \sin \frac{2u-2v}{2}$ | |
- Rewrite the sum or difference as a product of two functions.

| | | |
|--|---|---------------------------------------|
| (i) $\sin 70^\circ + \sin 30^\circ$ | (ii) $\sin 76^\circ - \sin 14^\circ$ | (iii) $\cos 58^\circ + \cos 12^\circ$ |
| (iv) $\cos \frac{p-q}{2} + \cos \frac{p+q}{2}$ | (v) $\sin(-10^\circ) + \sin(-20^\circ)$ | |
- Prove the following identities.

| | |
|---|--|
| (i) $\frac{\cos(\alpha + \beta)}{\cos(\alpha - \beta)} = \frac{1 - \tan \alpha \tan \beta}{1 + \tan \alpha \tan \beta}$ | (ii) $\frac{6\cos 8u \sin 2u}{\sin(-6u)} = \frac{-3\sin 10u}{\sin 6u} + 3$ |
| (iii) $4\cos 4v \sin 3v = 2(\sin 7v - \sin v)$ | (iv) $\sin 3\theta + \sin \theta = 4\cos^2 \theta \sin \theta$ |
| (v) $\cos 3x + \cos x = 2\cos x(\cos 2x)$ | (vi) $2\tan y \cos 3y = \sec y(\sin 4y - \sin 2y)$ |
| (vii) $\frac{\sin 6\beta + \sin 4\beta}{\sin 6\beta - \sin 4\beta} = \tan 5\beta \cot \beta$ | (viii) $\frac{\cot 3\theta + \cot \theta}{\cot 3\theta - \cot \theta} = -\cos 2\theta \cot \theta$ |

(ix) $\frac{\cos 6x + \cos 8x}{\sin 6x - \sin 4x} = \cot x \cos 7x \sec 5x$ (x) $\frac{\cos 2\alpha - \cos 4\alpha}{\sin 2\alpha + \sin 4\alpha} = \tan \alpha$
 (xi) $2\cos 2u \cos u + \sin 2u \sin u = 2\cos^3 u$ (xii) $2\sin 2y \sin 3y = \cos y - \cos 5y$
 (xiii) $\frac{\cos 10x + \cos 6x}{\cos 6x - \cos 10x} = \cot 2x \cot 8x$

4. Prove that.

(i) $\cos 80^\circ \cos 60^\circ \cos 40^\circ \cos 20^\circ = \frac{1}{16}$ (ii) $\sin 70^\circ \sin 50^\circ \sin 30^\circ \sin 10^\circ = \frac{1}{16}$
 (iii) $\sin \frac{\pi}{9} \sin \frac{2\pi}{9} \sin \frac{3\pi}{9} \sin \frac{4\pi}{9} = \frac{3}{16}$

I have Learnt

- Using distance formula to establish fundamental law of trigonometry:
 - $\cos(\alpha - \beta) = \cos \alpha \cos \beta + \sin \alpha \sin \beta$, and deduce that .
 - $\cos(\alpha + \beta) = \cos \alpha \cos \beta - \sin \alpha \sin \beta$ $\sin(\alpha \pm \beta) = \sin \alpha \cos \beta \pm \cos \alpha \sin \beta$,
 - $\tan(\alpha \pm \beta) = \frac{\tan \alpha \pm \tan \beta}{1 \mp \tan \alpha \tan \beta}$
- Defining allied angles and using fundamental law and its deductions to derive trigonometric ratios of allied angles.
- Expressing $a \sin \theta + b \cos \theta$ in the form $r \sin(\theta + \phi)$ where $a = r \cos \phi$ and $b = r \sin \phi$.
- Deriving double angle, half angle and triple angle identities from fundamental law and its deductions.
- Expressing the product (of sines and cosines) as sums or differences (of sines and cosines).
- Expressing the sums or differences (of sines and cosines) as products (of sines and cosines).

Review Exercise

1. Select the correct option in the following.

(i) $\sin(45^\circ - 30^\circ) = \dots$
 (a) $\frac{\sqrt{6} - \sqrt{2}}{4}$ (b) $\frac{\sqrt{6} + \sqrt{2}}{4}$ (c) $\frac{\sqrt{6} - \sqrt{2}}{2}$ (d) $\frac{\sqrt{3} - \sqrt{2}}{2}$

(ii) $\tan\left(\frac{\pi}{6} + \frac{\pi}{4}\right) = \dots$
 (a) $\frac{\sqrt{3} - 1}{\sqrt{3} + 1}$ (b) $\frac{\sqrt{3} + 1}{\sqrt{3} - 1}$ (c) $\frac{\sqrt{3} + 1}{-\sqrt{3} - 1}$ (d) $\frac{\sqrt{3} + 1}{-\sqrt{3} + 1}$

(iii) $\sin 22.5^\circ \cos 22.5^\circ + \cos 22.5^\circ \sin 22.5^\circ = \dots$
 (a) $\frac{-1}{\sqrt{3}}$ (b) $\frac{1}{\sqrt{3}}$ (c) $\frac{1}{\sqrt{2}}$ (d) $\frac{-1}{\sqrt{2}}$

(iv) $\cos(\pi - \theta) = \dots$

- (a) $\sec \theta$ (b) $\pm \cos \theta$ (c) $\cos \theta$ (d) $-\cos \theta$

(v) $\tan\left(\frac{\pi}{2} + \theta\right) = \dots$

- (a) $\cot \theta$ (b) $-\cot \theta$ (c) $\tan \theta$ (d) $-\tan \theta$

(vi) $2 \sin \alpha \cos \alpha = \dots$

- (a) $\sin(\pi - 2\alpha)$ (b) $\sin(\pi + 2\alpha)$ (c) $\sin(-2\alpha)$ (d) $\sin 2(\pi - \alpha)$

(vii) $\frac{\sin 2\alpha \cos \alpha}{\cos^3 \alpha - \cos \alpha \sin^2 \alpha} = \dots$

- (a) $\csc 2\alpha$ (b) $-\sec 2\alpha$ (c) $\tan 2\alpha$ (d) $-\tan 2\alpha$

(viii) If $\sin \beta = \frac{3}{5}$, then $\cos 2\beta = \dots$

- (a) $-\frac{7}{5}$ (b) $\frac{7}{5}$ (c) $-\frac{7}{25}$ (d) $\frac{7}{25}$

(ix) $\cos^2 3x - \sin^2 3x = \dots$

- (a) $\sin 6x$ (b) $\cos 6x$ (c) $-\sin 6x$ (d) $-\cos 6x$

(x) $(\sin x - \cos x)^2 = \dots$

- (a) $1 + \sin 2x$ (b) $1 - \cos 2x$ (c) $1 - \sin 2x$ (d) $1 + \cos \sin 2x$

(xi) $\cos(60^\circ - 30^\circ) = \dots$

- (a) $\cos 30^\circ$ (b) $\sec 30^\circ$ (c) $\sqrt{1 - \sin^2 30^\circ}$ (d) $\cos 60^\circ - \cos 30^\circ$

(xii) $\frac{1 - \cos x}{\sin x} = \dots$

- (a) $\tan\left(\frac{x}{2}\right)$ (b) $\cot\left(\frac{x}{2}\right)$ (c) $-\tan\left(\frac{x}{2}\right)$ (d) $-\cot\left(\frac{x}{2}\right)$

2. Given that $\sin \theta = \frac{3}{5}$, $\sin \phi = \frac{5}{13}$ where θ is obtuse and ϕ is acute. Find the values of:

- (i) $\sin(\theta - \phi)$ (ii) $\tan(\theta - \phi)$ (iii) $\tan(\theta + \phi)$

3. Express the following as single trigonometric ratios.

- (i) $\frac{1}{\sqrt{2}}(\sin \beta + \cos \beta)$ (ii) $\frac{1}{\sqrt{2}} \sin 75^\circ + \frac{1}{\sqrt{2}} \cos 75^\circ$

4. Find the values of:

- (i) $\frac{1 + \tan 15^\circ}{1 - \tan 15^\circ}$ (ii) $\cos 70^\circ \cos 20^\circ - \sin 70^\circ \sin 20^\circ$

5. Find the values of $\tan \theta$ when $\tan(\theta - 45^\circ) = \frac{1}{3}$.
6. (i) If $\sin(\alpha + \theta) = 2\cos(\alpha - \theta)$ prove that $\tan \alpha = \frac{2 - \tan \theta}{1 - 2 \tan \theta}$.
 (ii) If $\sin(\alpha - \theta) = \cos(\alpha + \theta)$ prove that $\tan \alpha = 1$.
7. Show that: (i) $\frac{4\sin^2 \theta \cos \theta}{\cos 3\theta + \cos \theta} = \tan 2\theta \tan \theta$ · (ii) $\frac{\sin 10\theta - \sin 4\theta}{\sin 4\theta + \sin 2\theta} = \cos 7\theta \sec \theta$
 (iii) If $\sin(\alpha - \theta) = \cos(\alpha + \theta)$ prove that $\tan \alpha = 1$.
8. Prove that: (i) $\sqrt{\frac{\cos(90^\circ + x) \sec(-x) \tan(180^\circ - x)}{\sec(360^\circ - x) \sin(180^\circ + x) \cot(90^\circ - x)}} = i$
 (ii) $\frac{\tan^2\left(\frac{3\pi}{2} - x\right) \sin^2(\pi + x) \sin(2\pi - x)}{\cos^2(\pi - x) \cot\left(\frac{3\pi}{2} + x\right)} = \cos x$ ·
9. Simplify $\sqrt{\frac{(1 - \tan^2 x \cos(-x) \cos(360^\circ - x)) \tan 45^\circ}{\{\sin 90^\circ - \sin(180^\circ + x)\} \{\sin 90^\circ - \cos(90^\circ - x)\}}}$
10. Prove that: (i) $\sin(16x) = 16 \sin(x) \cos(x) \cos(2x) \cos(4x) \cos(8x)$
 (ii) $\frac{1 + \cos 2\theta}{\sin 2\theta - \cos \theta} = \frac{2 \cos \theta}{2 \sin \theta - 1}$
 (iii) $\frac{\cos 3\theta - \cos \theta}{\cos 3\theta + \cos \theta} = \frac{2 \tan^2 \theta}{\tan^2 \theta - 1} = \frac{-2 \tan^2 \theta}{\sec^2 \theta - 2 \tan^2 \theta}$

UNIT
09

TRIGONOMETRIC FUNCTIONS

After studying this unit, students will be able to:

- Find the domain and range of the trigonometric functions.
- Discuss even and odd functions, and the periodicity of trigonometric functions.
- Find the maximum and minimum value of a given function of the type:
 - $a + b\sin\theta$,
 - $a + b\cos\theta$,
 - $a + b\sin(c\theta + d)$,
 - $a + b\cos(c\theta + d)$,
 - The reciprocal of above, where a, b, c and d are real numbers.
- Graph and analyze the trigonometric functions sine, cosine, and tangent to solve problems.
- Explain the properties of graphs of $\sin\theta$, $\cos\theta$ and $\tan\theta$.
- Apply the concepts of trigonometric functions, identities, graphs, periodicity, even, odd functions, and extreme values to real-world problems such as (distance, elevation, and direction of tall structures, navigation and mapping, lengths of irregular shapes, graphs to visualize and predict patterns in data, frequency and periodic length of Ferris wheel, forces on a see-saw or lever, the ideal angle for solar panel placement)

A Ferris wheel is 60 ft. in diameter. It makes one revolution every 100 seconds. Yasir climb up 6 feet of stairs to get on the wheel at its lowest point. Model the height of a rider as a sinusoidal function and graph 1 revolution.

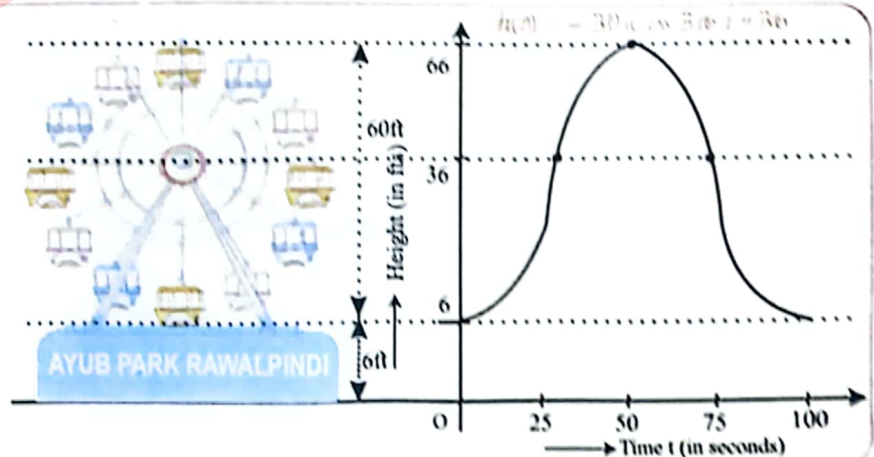

9.1 Domain and Range of Trigonometric Functions

The domain of a function $f(x)$ is the set of all possible values of 'x' such that function $f(x)$ is defined. The range of a function $f(x)$ is the set of all possible values the function $f(x)$ can take, when 'x' is any number from the domain of the function.

Let ' θ ' be any real number. Construct the angle whose measure is θ radian, with vertex at the origin of a rectangular coordinate system. Let the initial line of the angle ' θ ' be along x-axis. Let $P(x, y)$ be any point on the terminal side OA of the angle.

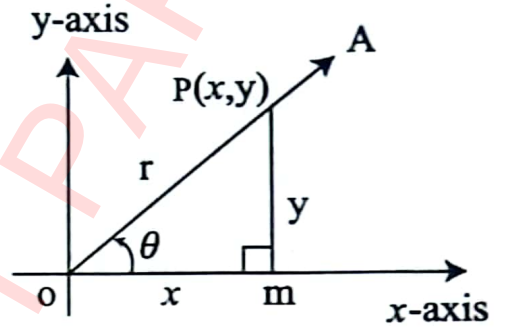

Let $\overline{OP} = r$

Then from r.a.t OMP:

(i) $\sin \theta = \frac{y}{r}$
 For any ' θ ' $-r \leq y \leq r$
 $\therefore -1 \leq \frac{y}{r} \leq 1$
 $-1 \leq \sin \theta \leq 1$

\therefore Domain of $\sin \theta = \mathbb{R}$ or $(-\infty, \infty)$ and range of $\sin \theta = [-1, 1]$

(ii) Again, from r.a.t OMP:

$\cos \theta = \frac{x}{r}$
 For any ' θ ' $-r \leq x \leq r$
 $\therefore -1 \leq \frac{x}{r} \leq 1$
 $-1 \leq \cos \theta \leq 1$

\therefore Domain of $\cos \theta = \mathbb{R}$ or $(-\infty, \infty)$ and range of $\cos \theta = [-1, 1]$

(iii) Since $\tan \theta$ is defined for any real number ' θ ' which is not an odd multiple of $\frac{\pi}{2}$.

For any such value of ' θ ', the ratio $\frac{y}{x}$ can be any real number.

\therefore Domain of $\tan \theta = \mathbb{R} - \{(2n + 1)\frac{\pi}{2}, n \in \mathbb{Z}\}$

Range of $\tan \theta = \mathbb{R}$

Key Facts

- $[a, b]$ is called closed interval of numbers from a to b and $[a, b] = a \leq x \leq b$.
- (a, b) is open interval such that $(a, b) = a < x < b$.

(iv) Cot θ is defined for any real number ' θ ' which is not an even multiple of $\frac{\pi}{2}$.

For any such value of ' θ ', the ratio $\frac{x}{y}$ can be any real number.

$$\therefore \text{Domain of Cot } \theta = \mathbb{R} - \{n\pi, n \in \mathbb{Z}\}$$

$$\text{Range of Cot } \theta = \mathbb{R}$$

(v) Sec θ is defined for any real number ' θ ' which is not an odd multiple of $\frac{\pi}{2}$.

For any such value of ' θ ', we have:

$$\therefore -1 \leq \frac{x}{r} \leq 1 \quad \text{i.e.,} \quad \left| \frac{x}{r} \right| \leq 1$$

$$\Rightarrow \left| \frac{1}{\frac{x}{r}} \right| \geq 1 \Rightarrow \left| \frac{r}{x} \right| \geq 1 \Rightarrow |\text{Sec } \theta| \geq 1$$

$$\therefore \text{Domain of Sec } \theta = \mathbb{R} - \left\{ (2n+1)\frac{\pi}{2}, n \in \mathbb{Z} \right\}$$

$$\text{Range of Sec } \theta = \mathbb{R} - (-1, 1)$$

(vi) Cosec θ is defined for any real number ' θ ' which is not an even multiple of $\frac{\pi}{2}$.

For any such value of ' θ ', we have:

$$\therefore -1 \leq \frac{y}{r} \leq 1 \quad \text{i.e.,} \quad \left| \frac{y}{r} \right| \leq 1$$

$$\Rightarrow \left| \frac{1}{\frac{y}{r}} \right| \geq 1 \Rightarrow \left| \frac{r}{y} \right| \geq 1 \Rightarrow |\text{Cosec } \theta| \geq 1$$

$$\therefore \text{Domain of Cosec } \theta = \mathbb{R} - \{n\pi, n \in \mathbb{Z}\}$$

$$\text{Range of Cosec } \theta = \mathbb{R} - (-1, 1)$$

Remark-I

The maximum (i.e., greatest) value of Sin θ and Cos θ is 1 and minimum (i.e., least) value is -1 .

$$\therefore \text{(i) } |\text{Sin } \theta| \leq 1; \text{ i.e., } -1 \leq \text{Sin } \theta \leq 1; \text{ i.e., } \text{Sin}^2 \theta \leq 1.$$

$$\text{(ii) } |\text{Cos } \theta| \leq 1; \text{ i.e., } -1 \leq \text{Cos } \theta \leq 1; \text{ i.e., } \text{Cos}^2 \theta \leq 1.$$

Remark-II

Tan θ and Cot θ can take any real number value.

Remark-III

Sec θ and Cosec θ cannot take value in the interval $(-1, 1)$.

$$\therefore |\text{Sec } \theta| \geq 1, \text{ i.e., } \text{Sec}^2 \theta \geq 1$$

$$|\text{Cosec } \theta| \geq 1, \text{ i.e., } \text{Cosec}^2 \theta \geq 1$$

Therefore, domain of $y = D_y = \mathbb{R} - \{x : x \in \mathbb{R} \text{ and } x \neq (2n\pi + \frac{\pi}{3}) \wedge x \neq (2n\pi + \frac{5\pi}{3}), n \in \mathbb{Z}\}$.

Now, we find the range of (i), since, range of cosine function is $[-1, 1]$.

We have

$$-1 \leq \cos x \leq 1$$

$$-2 \leq 2 \cos x \leq 2$$

$$-2 - 1 \leq 2 \cos x - 1 \leq 2 - 1$$

$$-3 \leq 2 \cos x - 1 \leq 1$$

We get

$$1 \leq \frac{1}{2 \cos x - 1} \leq \frac{-1}{3}$$

From (ii)

$$1 \leq y \leq \frac{-1}{3}$$

$$y \leq \frac{-1}{3} \text{ and } 1 \leq y$$

Thus,

$$\text{Range of } y = R_y = (-\infty, -\frac{1}{3}] \cup [1, +\infty)$$

(iii)

We are given

$$y = \frac{1}{1 + 2 \sin x} \dots\dots\dots(iii)$$

Since (i) is defined for all real values of 'x' except

$$\{x : x \in \mathbb{R} \text{ and } x \neq (2n\pi + \frac{7\pi}{6}) \wedge x \neq (2n\pi + \frac{11\pi}{6}), n \in \mathbb{Z}\}$$

Therefore, domain of $y = D_y = \mathbb{R} - \{x : x \in \mathbb{R} \text{ and } x \neq (2n\pi + \frac{7\pi}{6}) \wedge x \neq (2n\pi + \frac{11\pi}{6}), n \in \mathbb{Z}\}$.

Now, we find the range of (i), since, range of sine function is $[-1, 1]$.

Similarly,

$$-1 \leq \sin x \leq 1$$

$$-2 \leq 2 \sin x \leq 2$$

$$-2 + 1 \leq 2 \sin x + 1 \leq 2 + 1$$

$$-1 \leq 2 \sin x + 1 \leq 3$$

We get

$$\frac{1}{3} \leq \frac{1}{2 \sin x + 1} \leq -1$$

From (iii)

$$\frac{1}{3} \leq y \leq -1$$

$$\frac{1}{3} \leq y \text{ and } y \leq -1$$

Therefore,

$$\text{Range of } y = R_y = (-\infty, -1] \cup [\frac{1}{3}, +\infty)$$

(iv) We are given $y = \frac{1}{2 - \sin 3x}$ (iv)

To find the domain of (i), we can see that $2 - \sin 3x$ should not be equal to "0", i.e.,
 $2 - \sin 3x \neq 0$
 $\sin 3x \neq 2$

Which is understood because $-1 \leq \sin 3x \leq 1$, so (i) is defined for all real values of 'x'.

Hence, Domain of $y = D_y = (-\infty, \infty)$ or R .

Now, we find the range of (i), since, range of sine function is $[-1, 1]$.

We have

$$\begin{aligned} -1 &\leq \sin 3x \leq 1 \\ -(-1) &\geq -\sin 3x \geq -1 \\ 1 &\geq -\sin 3x \geq -1 \\ 2 + 1 &\geq 2 - \sin 3x \geq 2 - 1 \end{aligned}$$

From (iv)

$$\begin{aligned} 3 &\geq 2 - \sin 3x \geq 1 \\ \frac{1}{3} &\leq \frac{1}{2 - \sin 3x} \leq 1 \end{aligned}$$

Therefore,

$$\text{Range of } y = R_y = \left[\frac{1}{3}, 1\right]$$

9.22 Periodicity of Trigonometric Functions

We often encounter periodic phenomenon in the nature, technology, and human society. Recall the 24-hour day-night cycle, or tidal cycles caused by the moon revolving around the earth.

A periodic function is a function whose value repeats after a specific time interval. A periodic function is represented as :

$$f(x + p) = f(x)$$

Where "p" is the period of the function. For example, Sine wave, triangular wave, square wave, and saw tooth wave are periodic in nature.



All trigonometric functions repeat itself at regular intervals, or periods. The values of trigonometric functions for ' θ ' and ' $2n\pi \pm \theta$ ', where $\theta \in R$ and $n \in Z$, are same. This periodic behavior of trigonometric functions is called periodicity.

| | | |
|--------|---|--------------------------------------|
| $f(x)$ | → | Periodic , $p > 0$, $f(p+x) = f(x)$ |
| "p" | → | Period of the function |

9.2.1 Periodicity of Sine Function

Suppose “ p ” is the period of Sine function, then:

$$\sin(\theta + p) = \sin \theta \dots\dots\dots(i) \quad \text{where } \theta \in R.$$

Now putting $\theta = 0$, we have:

$$\sin(0 + p) = \sin 0$$

$$\Rightarrow \sin p = 0$$

$$\Rightarrow p = \sin^{-1}(0) = 0, \pm \pi, \pm 2\pi, \pm 3\pi, \dots$$

Key Facts



Period of a trigonometric function is the smallest +ve integer which when added to the original circular measure of the angle, gives the same value of the function.

Case 1: Put $p = \pi$ in (i), $\sin(\theta + \pi) = \sin \theta$, which is not true.

$$\therefore \sin(\pi + \theta) = -\sin \theta$$

$\therefore \pi$ is not the period of $\sin \theta$.

Case 2: Put $p = 2\pi$ in (i)

$$\sin(\theta + 2\pi) = \sin \theta \dots\dots\dots(ii)$$

From (ii) L.H.S = $\sin(2\pi + \theta) = \sin(4\frac{\pi}{2} + \theta) = \sin \theta =$ R.H.S

Since terminal side of angle is in first quadrant, and ‘ 2π ’ is the smallest +ve real number for which:

$$\sin(\theta + 2\pi) = \sin \theta.$$

$\therefore 2\pi$ is the period of $\sin \theta$.

Key Facts



Cosine is the periodic function and its period is 2π .

$$\cos(\theta + 2\pi) = \cos \theta$$

9.2.2 Periodicity of Tangent Function

Suppose “ p ” is the period of Tangent function, then:

$$\tan(\theta + p) = \tan \theta \dots\dots\dots(i) \quad \text{where } \theta \in R.$$

Now putting $\theta = 0$ in (i), we have:

$$\tan(0 + p) = \tan 0$$

$$\Rightarrow \tan p = 0$$

$$\Rightarrow p = \tan^{-1}(0) = 0, \pi, 2\pi, 3\pi, \dots$$

Put $p = \pi$ in (i)

$$\tan(\theta + \pi) = \tan \theta \dots\dots\dots(ii)$$

From (ii): L.H.S = $\tan(\pi + \theta) = \tan(2\frac{\pi}{2} + \theta) = \tan \theta =$ R.H.S

Since terminal side of an angle is in third quadrant, and ‘ π ’ is the least +ve real number for which:

$$\tan(\theta + \pi) = \tan \theta$$

$\therefore \pi$ is the period of $\tan \theta$.

Key Facts



Cotangent is the periodic function and its period is π .
 $\cot(\theta + \pi) = \cot \theta$

If “P” is the period of a periodic function $f(x)$, then $\frac{1}{f(x)}$ is also a periodic function and will have the same period “P” as $f(x)$.

Thus, $y = \operatorname{cosec} \theta$ is a periodic function and its period is 2π because $\sin \theta = \frac{1}{\operatorname{cosec} \theta}$.

Similarly, $y = \sec \theta$ is a periodic function and its period is 2π because $\cos \theta = \frac{1}{\sec \theta}$.

If “P” is the period of the periodic function $f(x)$, then $f(ax + b)$, $a > 0$ is also a periodic function with a period $\frac{P}{|a|}$.

| Trigonometric Functions | Period | Trigonometric Function | Period |
|---------------------------------|--------|---|--------------------|
| $f(x) = \sin x$ | 2π | $f(x) = \sin ax$ or $f(x) = \sin(ax + b)$ | $\frac{2\pi}{ a }$ |
| $f(x) = \cos x$ | 2π | $f(x) = \cos ax$ or $f(x) = \cos(ax + b)$ | $\frac{2\pi}{ a }$ |
| $f(x) = \tan x$ | π | $f(x) = \tan ax$ or $f(x) = \tan(ax + b)$ | $\frac{\pi}{ a }$ |
| $f(x) = \cot x$ | π | $f(x) = \cot ax$ or $f(x) = \cot(ax + b)$ | $\frac{\pi}{ a }$ |
| $f(x) = \sec x$ | 2π | $f(x) = \sec ax$ or $f(x) = \sec(ax + b)$ | $\frac{2\pi}{ a }$ |
| $f(x) = \operatorname{cosec} x$ | 2π | $f(x) = \operatorname{cosec} ax$ or $f(x) = \operatorname{cosec}(ax + b)$ | $\frac{2\pi}{ a }$ |

Example:

Find the periods of:

- (i) $f(x) = \sin 3x$ (ii) $f(x) = \cos \frac{2x}{5}$ (iii) $f(x) = \tan \frac{5x}{7}$

Solution:

- (i) We know that period of sine function is 2π , i. e., period of $\sin x = 2\pi$

Period of $\sin(ax + b) = \frac{2\pi}{|a|}$, where $a = 3$

\Rightarrow Period of $\sin 3x = \frac{2\pi}{3}$

(ii) We know that period of $\cos x = 2\pi$

Period of $\cos(ax + b) = \frac{2\pi}{|a|}$, where $a = \frac{2}{5}$

\Rightarrow Period of $\cos \frac{2x}{5} = \frac{2\pi}{\frac{2}{5}} = 2\pi \cdot \frac{5}{2} = 5\pi$.

Hence, 5π is period of $\cos \frac{2x}{5}$.

Check: Since ' 5π ' is period of $\cos \frac{2x}{5}$.

$\therefore \cos(\frac{2x}{5} + 5\pi) = \cos \frac{2}{5}(x + 2\pi)$

This clearly shows that ' 5π ' is period of $\cos \frac{2x}{5}$.

(iii) We know that the period of Tangent is π , i.e., Period of $\tan x = \pi$.

Period of $\tan(ax + b) = \frac{\pi}{|a|}$, where $a = \frac{5}{7}$

\Rightarrow Period of $\tan \frac{5x}{7} = \frac{\pi}{\frac{5}{7}} = \pi \cdot \frac{7}{5} = \frac{7\pi}{5}$.

Hence, $\frac{7\pi}{5}$ is period of $\tan \frac{5x}{7}$.

Note: If " p " is the period of the periodic function $f(x)$ then $a f(x) + b$, $a > 0$, is also a periodic function with a period of " p ",

Key Facts

- Periodicity of $\cos^n(x) = \frac{2\pi}{2} = \pi$
= $\frac{\text{Periodicity of } \cos x}{2}$ (if ' n ' is even)
- Periodicity of $\cos^n(x)$
= Periodicity of $\cos x$
= 2π (if ' n ' is odd)
- Similarly, for Sine function.
- Periodicity of $\tan^n(x)$
= Periodicity of $\tan x$
(no matter ' n ' is even or odd).

| Trigonometric Functions | Period | Trigonometric Function | Period |
|-------------------------|--------|---------------------------------------|--------|
| $f(x) = a \sin x + b$ | 2π | $f(x) = a \operatorname{cosec} x + b$ | 2π |
| $f(x) = a \cos x + b$ | 2π | $f(x) = a \sec x + b$ | 2π |
| $f(x) = a \tan x + b$ | π | $f(x) = a \cot x + b$ | π |

Example: Find the period of $f(x) = \cot 3x + \sin \frac{2x}{3}$.

Solution:

| Period of $f(x) = \cot 3x$ | Period of $f(x) = \sin \frac{2x}{3}$ |
|--|---|
| Since, period of $\cot x = \pi$ | Since, period of $\sin x = 2\pi$ |
| Period of $\cot(ax + b) = \frac{\pi}{ a }$ where $a = 3$ | Period of $\sin(ax + b) = \frac{2\pi}{ a }$ where $a = \frac{2}{3}$ |
| Thus, the period of $\cot 3x = \frac{\pi}{3}$ | Thus, the period of $\sin \frac{2x}{3} = \frac{2\pi}{\frac{2}{3}} = 3\pi$ |

Hence,

$$\text{Period of } f(x) = \frac{\text{L.C.M of } \pi \text{ and } 3\pi}{\text{H.C.F of } 3 \text{ and } 1} = \frac{3\pi}{1} = 3\pi$$

Hence, 3π is a period of $\cot 3x + \sin \frac{2x}{3}$.

Example: Find the period of $f(x) = 7 \sin (3x + 5)$.

Solution: $f(x) = 7 \sin (3x + 5)$

Since, period of $\sin x = 2\pi$

$$\text{Period of } \sin (ax + b) = \frac{2\pi}{|a|} \text{ where } a = 3$$

Thus, the period of $7 \sin (3x + 5) = \frac{2\pi}{3}$.

9.5 Maximum and Minimum Values of Trigonometric Functions

(i) $a + b \sin \theta$

(ii) $a + b \cos \theta$

(iii) $a + b \sin (c\theta + d)$

(iv) $a + b \cos (c\theta + d)$

The reciprocal of the above where a, b, c and d are real numbers.

(i) $a + b \sin \theta$

$$\text{Maximum value (M)} = a + |b| \quad (1)$$

$$= a + |b| \Rightarrow \text{when } \sin \theta = 1$$

or $a + b \sin \theta$ is maximum when $b \sin \theta$ is maximum and it is maximum when $\sin \theta$ is maximum.

As $\sin \theta$ is maximum when $\sin \theta = 1$.

$$\text{Minimum value (m)} = a + |b| (-1)$$

$$= a - |b| \Rightarrow \text{when } \sin \theta = -1$$

or $a + b \sin \theta$ is minimum when $b \sin \theta$ is minimum and it is minimum when $\sin \theta$ is minimum.

We know that $\sin \theta$ is minimum when $\sin \theta = -1$.

(ii) $a + b \cos \theta$

$$\text{Maximum value (M)} = a + |b| \quad (1)$$

$$= a + |b| \Rightarrow \text{when } \cos \theta = 1$$

or $a + b \cos \theta$ is maximum when $b \cos \theta$ is maximum and it is maximum when $\cos \theta$ is maximum.

As $\cos \theta$ is maximum when $\cos \theta = 1$.

$$\text{Minimum value (m)} = a + |b| (-1)$$

$$= a - |b| \Rightarrow \text{when } \cos \theta = -1$$

or $a + b \cos \theta$ is minimum when $b \cos \theta$ is minimum and it is minimum when $\cos \theta$ is minimum.

As $\cos \theta$ is minimum when $\cos \theta = -1$.

(iii) $a + b \sin (c\theta + d)$

$$\text{Maximum value (M)} = a + |b| \quad (1)$$

$$= a + |b| \Rightarrow \text{when } \sin (c\theta + d) = 1$$

or $a + b \sin (c\theta + d)$ is maximum when $b \sin (c\theta + d)$ is maximum and it is maximum when $\sin (c\theta + d)$ is maximum. As $\sin (c\theta + d)$ is maximum when $\sin (c\theta + d) = 1$.

$$\begin{aligned} \text{Minimum value (m)} &= a + |b| (-1) \\ &= a - |b| \Rightarrow \text{when } \sin (c\theta + d) = -1 \end{aligned}$$

or $a + b \sin (c\theta + d)$ is minimum when $b \sin (c\theta + d)$ is minimum and it is minimum when $\sin (c\theta + d)$ is minimum. As $\sin (c\theta + d)$ is minimum when $\sin (c\theta + d) = -1$.

(iv) $a + b \cos (c\theta + d)$

$$\begin{aligned} \text{Maximum value (M)} &= a + |b| (1) \\ &= a + |b| \Rightarrow \text{when } \cos (c\theta + d) = 1 \end{aligned}$$

or $a + b \cos (c\theta + d)$ is maximum when $b \cos (c\theta + d)$ is maximum and it is maximum when $\cos (c\theta + d)$ is maximum. As $\cos (c\theta + d)$ is maximum when $\cos (c\theta + d) = 1$.

$$\begin{aligned} \text{Minimum value (m)} &= a + |b| (-1) \\ &= a - |b| \Rightarrow \text{when } \cos (c\theta + d) = -1 \end{aligned}$$

or $a + b \cos (c\theta + d)$ is minimum when $b \cos (c\theta + d)$ is minimum and it is minimum when $\cos (c\theta + d)$ is minimum. As $\cos (c\theta + d)$ is minimum when $\cos (c\theta + d) = -1$.

Example: Find the maximum and minimum values of $y = 3 + 4 \sin \theta$.

Solution: $y = 3 + 4 \sin \theta \dots\dots\dots(i)$

Since, $y = a + b \sin \theta \dots\dots\dots(ii)$

Comparing coefficients of (i) and (ii):

$$a = 3 \quad \text{and} \quad b = 4$$

$$\text{Maximum value (M)} \quad a + |b| = 3 + 4 = 7$$

$$M = 7$$

$$\text{Minimum value (m)} \quad a - |b| = 3 - 4 = -1$$

$$m = -1$$

Example: Find the maximum and minimum values of $y = \frac{1}{3} - 5 \cos \theta$.

Solution: $y = \frac{1}{3} - 5 \cos \theta \dots\dots\dots(i)$

Since, $y = a + b \cos \theta \dots\dots\dots(ii)$

Comparing coefficients of (i) and (ii):

$$a = \frac{1}{3} \quad \text{and} \quad b = -5$$

$$\text{Maximum value (M)} \quad a + |b| = \frac{1}{3} + |-5|$$

$$= \frac{1}{3} + 5 = \frac{16}{3}$$

$$M = \frac{16}{3}$$

$$\text{Minimum value (m)} \quad a - |b| = \frac{1}{3} - |-5|$$

$$= \frac{1}{3} - 5 = \frac{-14}{3}$$

$$m = \frac{-14}{3}$$

Example: Find the maximum and minimum values of the following trigonometric functions.

- (i) $y = 1 + 2 \sin \theta$ (ii) $y = 3 + 2 \cos (3\theta - 2)$ (iii) $y = \frac{1}{1 + 3 \sin (2\theta - 15)}$

Solution: (i) $y = 1 + 2 \sin \theta \dots\dots\dots(i)$

Since, $y = a + b \sin \theta \dots\dots\dots(ii)$

Comparing coefficients of (i) and (ii):

$a = 1$ and $b = 2$

Maximum value (M)

$a + |b| = 1 + 2 = 3$

$M = 3$

Minimum value (m)

$a - |b| = 1 - 2 = -1$

$m = -1$

(ii) $y = 3 + 2 \cos (3\theta - 2) \dots\dots\dots(i)$

Since, $y = a + b \cos (c\theta + d) \dots\dots\dots(ii)$

Comparing coefficients of (i) and (ii)

$a = 3$ and $b = 2$

Maximum value (M)

$a + |b| = 3 + 2 = 5$

$M = 5$

Minimum value (m)

$a - |b| = 3 - 2 = 1$

$m = 1$

(iii) $y = \frac{1}{1 + 3 \sin (2\theta - 15)} \dots\dots\dots(i)$

Then the corresponding reciprocal function of (i) is

$y' = 1 + 3 \sin (2\theta - 15) \dots\dots\dots(ii)$

Since, $y = a + b \sin (c\theta + d) \dots\dots\dots(iii)$

Comparing coefficients of (ii) and (iii):

$a = 1$ and $b = 3$

Maximum value (M)

$a + |b| = 1 + 3 = 4$

$M = 4 > 0$

Minimum value (m)

$a - |b| = 1 - 3 = -2$

$m = -2 < 0$

Now for maximum value of (i)

Let

$M' = \frac{1}{M} = \frac{1}{4}$

$M' = \frac{1}{4}$

Now for minimum value of (i)

Let

$m' = \frac{1}{m} = \frac{1}{-2}$

$m' = \frac{1}{-2}$

Note: If $M > 0$ and $m > 0$, then

$M' = \frac{1}{m}$

and

$m' = \frac{1}{M}$

9.4 Graphs of Trigonometric Functions

All the trigonometric functions are periodic functions. We can draw their graphs on the intervals of lengths equal to their periods. Because, when the graph of a periodic function of period 'p' is drawn in a given interval, then it is sufficient to draw its graph only in that interval. Further, it can easily be drawn completely by repeating it over the intervals of lengths 'p'.

Procedure for Sketching Graphs of Sine and Cosine Functions

To graph $y = a \sin bx$ or $y = a \cos bx$, with $b > 0$, follow these steps.

Step 1: Find the period $\frac{2\pi}{b}$. Initially, start from "0" on the x-axis, and lay off a distance of $\frac{2\pi}{b}$.

Step 2: Divide the given interval into four equal parts:

- Find the midpoint of the given interval by adding the end-points of each interval and dividing the sum by 2.
- Find the quarter points (the midpoints of the two intervals obtained in part (a)).
- Continue in the same way until the required number of equal parts are obtained.

Step 3: Evaluate the function for each of the five/nine/thirteen x-values resulting from step 2.

The resulting points will be maximum points, minimum points, and x-intercepts.

Step 4: Plot the points obtained in step 3 and join them with a sinusoidal curve having amplitude $|a|$.

Step 5: Draw the graph over additional periods if required.

| Angles in Degrees and Radians | | | | | | | | | | | | |
|-------------------------------|-----------------|-----------------|-----------------|------------------|------------------|-------|------------------|------------------|------------------|------------------|-------------------|--------|
| 0 | $\frac{\pi}{6}$ | $\frac{\pi}{3}$ | $\frac{\pi}{2}$ | $\frac{2\pi}{3}$ | $\frac{5\pi}{6}$ | π | $\frac{7\pi}{6}$ | $\frac{4\pi}{3}$ | $\frac{3\pi}{2}$ | $\frac{5\pi}{3}$ | $\frac{11\pi}{6}$ | 2π |
| 0° | 30° | 60° | 90° | 120° | 150° | 180° | 210° | 240° | 270° | 300° | 330° | 360° |

Graph of $y = \sin x$

We know that $\sin x$ is a periodic function of period 2π .

Step 1: For this function $b = 1$, so the period is 2π .

The function will be graphed over the interval $[0, 2\pi]$.

Step 2: Divides the interval $[0, 2\pi]$ in twelve equal parts to obtain the x-values:

$$0, \frac{\pi}{6}, \frac{\pi}{3}, \frac{\pi}{2}, \frac{2\pi}{3}, \frac{5\pi}{6}, \pi, \frac{7\pi}{6}, \frac{4\pi}{3}, \frac{3\pi}{2}, \frac{5\pi}{3}, \frac{11\pi}{6}, 2\pi$$

Step 3: For this, we first construct the table determined by the x-values in Step 2.

| | | | | | | | | | | | | | |
|-------|---|-----------------|-----------------|-----------------|------------------|------------------|-------|------------------|------------------|------------------|------------------|-------------------|--------|
| x | 0 | $\frac{\pi}{6}$ | $\frac{\pi}{3}$ | $\frac{\pi}{2}$ | $\frac{2\pi}{3}$ | $\frac{5\pi}{6}$ | π | $\frac{7\pi}{6}$ | $\frac{4\pi}{3}$ | $\frac{3\pi}{2}$ | $\frac{5\pi}{3}$ | $\frac{11\pi}{6}$ | 2π |
| Sin x | 0 | 0.5 | 0.86 | 1 | 0.86 | 0.5 | 0 | -0.5 | -0.86 | -1 | -0.86 | -0.5 | 0 |

Step 4: Plot the points $(0, 0), (\frac{\pi}{6}, 0.5), (\frac{\pi}{3}, 0.86), (\frac{\pi}{2}, 1), (\frac{2\pi}{3}, 0.86), (\frac{5\pi}{6}, 0.5),$

$$(\pi, 0), (\frac{7\pi}{6}, -0.5), (\frac{4\pi}{3}, -0.86), (\frac{3\pi}{2}, -1), (\frac{5\pi}{3}, -0.86), (\frac{11\pi}{6}, -0.5), (2\pi, 0).$$

Step 5: Join them with a sinusoidal curve having amplitude 1.

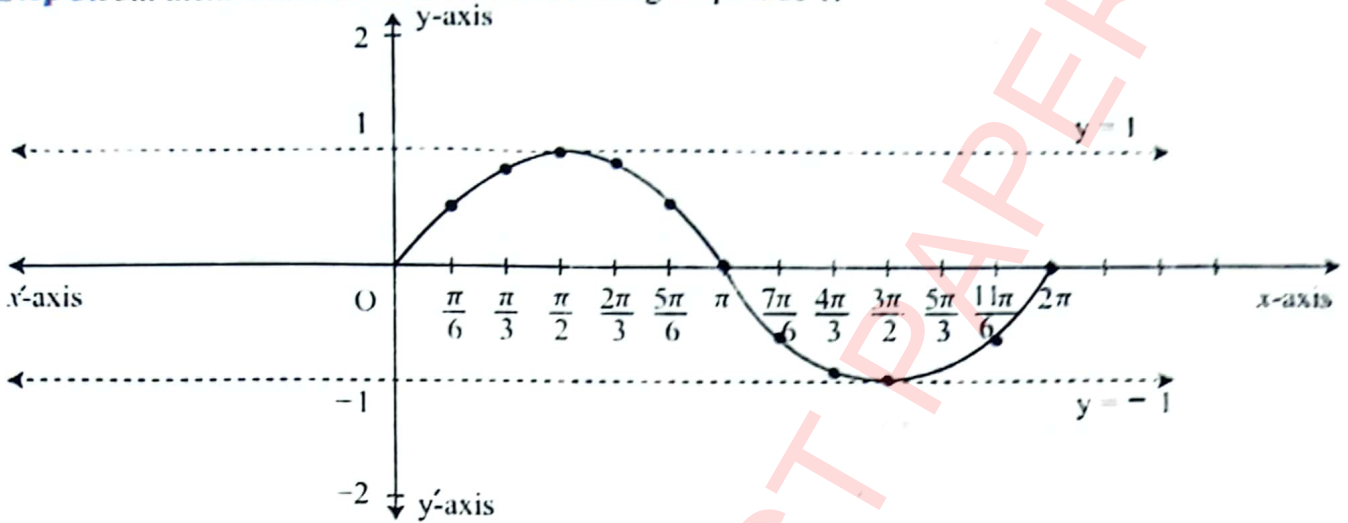

Step 6: Extend the graph by repeating the cycle, from 0 to -2π .

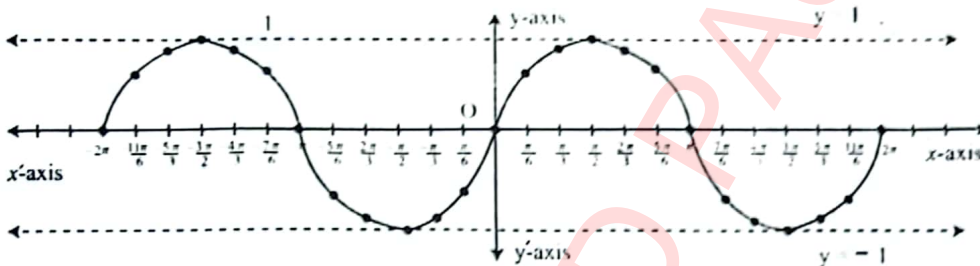

Characteristics

- Domain = $(-\infty, \infty) = \mathbb{R}$
- Range = $[-1, 1]$
- Period = 2π
- Amplitude = 1
- Nature = odd function

The graph in the interval $[0, 2\pi]$ is called a cycle. Since the period of the Sine function is 2π . So, the sine graph can be extended on both side of x-axis through every interval of 2π .

Graph of $y = \cos x$

We know that $\cos x$ is a periodic function of period 2π .

Step 1: For this function $b = 1$, so the period is 2π . The function will be graphed over the interval $[0, 2\pi]$.

Step 2: Divides the interval $[0, 2\pi]$ in twelve equal parts to obtain the x-values:

$$0, \frac{\pi}{6}, \frac{\pi}{3}, \frac{\pi}{2}, \frac{2\pi}{3}, \frac{5\pi}{6}, \pi, \frac{7\pi}{6}, \frac{4\pi}{3}, \frac{3\pi}{2}, \frac{5\pi}{3}, \frac{11\pi}{6}, 2\pi$$

Step 3: For this, we first construct the table determined by the x-values in Step 2.

| | | | | | | | | | | | | | |
|----------|---|-----------------|-----------------|-----------------|------------------|------------------|-------|------------------|------------------|------------------|------------------|-------------------|--------|
| x | 0 | $\frac{\pi}{6}$ | $\frac{\pi}{3}$ | $\frac{\pi}{2}$ | $\frac{2\pi}{3}$ | $\frac{5\pi}{6}$ | π | $\frac{7\pi}{6}$ | $\frac{4\pi}{3}$ | $\frac{3\pi}{2}$ | $\frac{5\pi}{3}$ | $\frac{11\pi}{6}$ | 2π |
| $\cos x$ | 1 | 0.86 | 0.5 | 0 | -0.5 | -0.86 | -1 | -0.86 | -0.5 | 0 | 0.5 | 0.86 | 1 |

Step 4: Plot the points $(0, 0)$, $(\frac{\pi}{6}, 0.86)$, $(\frac{\pi}{3}, 0.5)$, $(\frac{\pi}{2}, 0)$, $(\frac{2\pi}{3}, -0.5)$, $(\frac{5\pi}{6}, -0.86)$.

$(\pi, -1)$, $(\frac{7\pi}{6}, -0.86)$, $(\frac{4\pi}{3}, -0.5)$, $(\frac{3\pi}{2}, 0)$, $(\frac{5\pi}{3}, 0.5)$, $(\frac{11\pi}{6}, 0.86)$, $(2\pi, 1)$.

Step 5: Join them with a sinusoidal curve having amplitude 1.

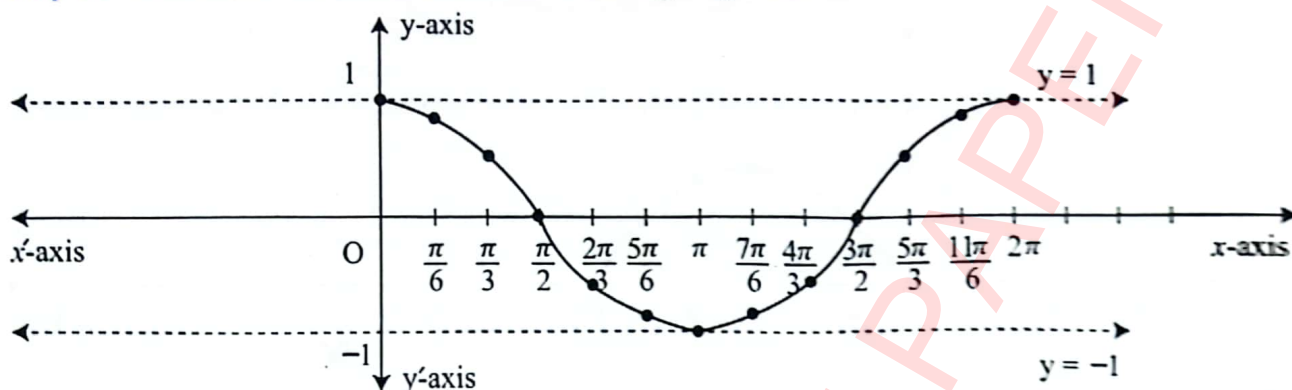

Step 6: Extend the graph by repeating the cycle, from 0 to -2π .

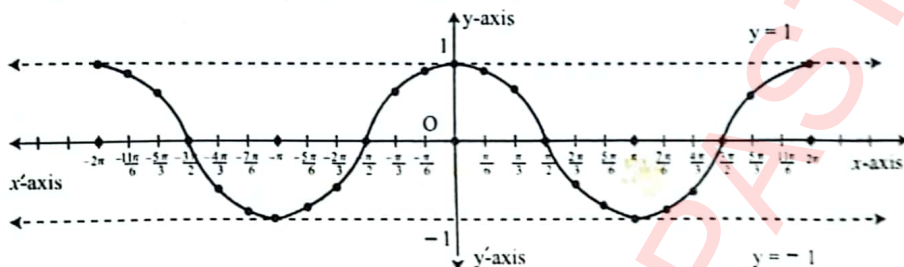

Characteristics

- Domain = $(-\infty, \infty) = \mathbb{R}$
- Range = $[-1, 1]$
- Period = 2π
- Amplitude = 1
- Nature = even function

The graph in the interval $[0, 2\pi]$ is called a cycle. Since the period of the Cosine function is 2π . So, the Cosine graph can be extended on both side of x -axis through every interval of 2π .

Graph of $y = \tan x$

We know that $\tan x$ is a periodic function of period π .

Step 1: For this function $b = 1$, so the period is π . The function will be graphed over the interval $[0, \pi]$.

Step 2: Divides the interval $[0, \pi]$ in twelve equal parts (From 0 to $\pm\pi$) to obtain the x -values:

$$0, \pm \frac{\pi}{6}, \pm \frac{\pi}{3}, \pm \frac{\pi}{2}, \pm \frac{2\pi}{3}, \pm \frac{5\pi}{6}, \pm \pi$$

Initially, we draw the graph of tangent function from 0 to $\pm\pi$.

Step 3: For this, we first construct the table determined by the x -values in Step 2.

| | | | | | | | | | | | | | |
|---------|--------|-------------------|-------------------|------------------|------------------|------------------|---|-----------------|-----------------|-----------------|------------------|------------------|-------|
| x | $-\pi$ | $-\frac{5\pi}{6}$ | $-\frac{2\pi}{3}$ | $-\frac{\pi}{2}$ | $-\frac{\pi}{3}$ | $-\frac{\pi}{6}$ | 0 | $\frac{\pi}{6}$ | $\frac{\pi}{3}$ | $\frac{\pi}{2}$ | $\frac{2\pi}{3}$ | $\frac{5\pi}{6}$ | π |
| Tan x | 0 | 0.58 | 1.73 | $-\infty$ | -1.73 | -0.58 | 0 | 0.58 | 1.73 | ∞ | -1.73 | -0.58 | 0 |

Step 4: Plot the points $(-\pi, 0), (-\frac{5\pi}{6}, 0.58), (-\frac{2\pi}{3}, 1.73), (-\frac{\pi}{2}, -\infty), (-\frac{\pi}{3}, -1.73), (-\frac{\pi}{6}, -0.58), (0, 0), (\frac{\pi}{6}, 0.58), (\frac{\pi}{3}, 1.73), (\frac{\pi}{2}, \infty), (\frac{2\pi}{3}, -1.73), (\frac{5\pi}{6}, -0.58), (\pi, 0)$.

Join these points by a free hand curve to obtain the graph of $\tan x$.

Step 5: Since tangent is a periodic function of period π . So we shall first draw the graph in the interval $[-\pi, \pi]$.

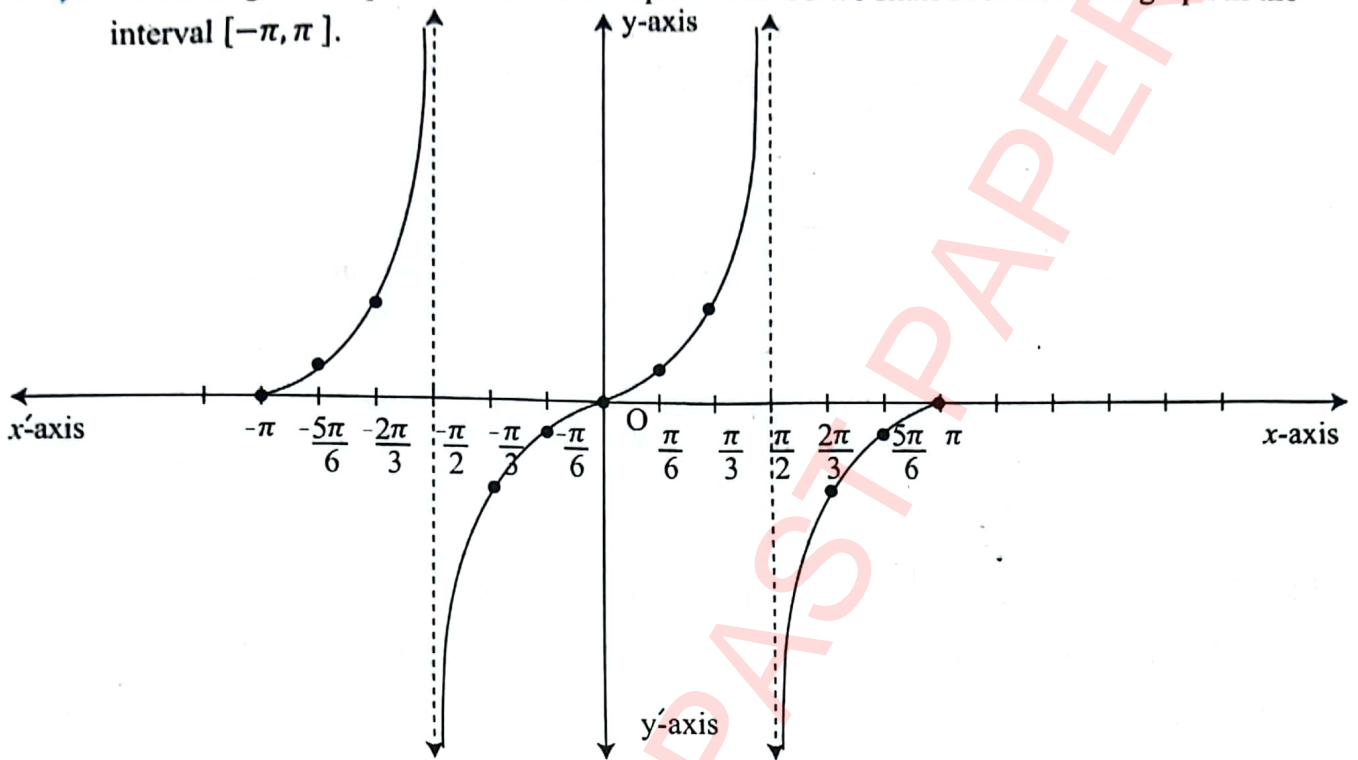

In the similar way, we can draw the graphs for the interval from -2π to 2π .

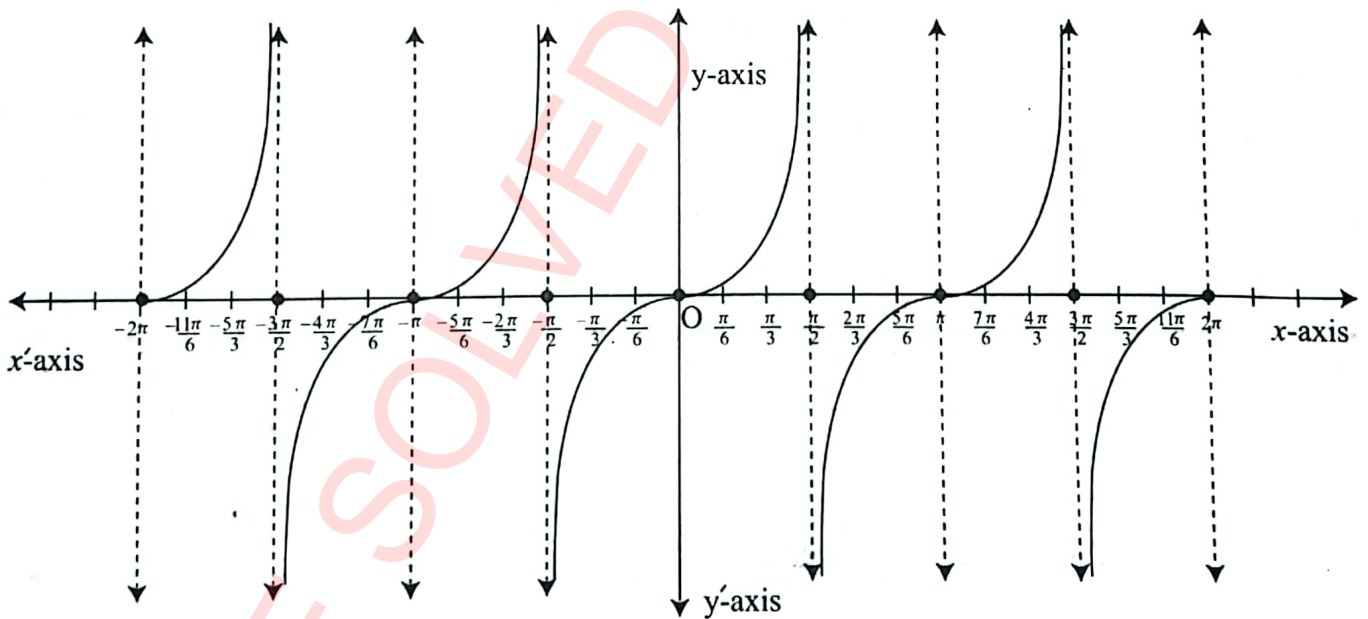

Characteristics

- Domain = $\{x: x \in \mathbb{R} \text{ and } x \neq (2n + 1)\frac{\pi}{2}, n \text{ an integer}\}$
- Range = $(-\infty, \infty) = \mathbb{R}$
- Period = π
- Amplitude = nil
- Nature = odd function

The graph in the interval $[0, \pi]$ is called a cycle. Since the period of the Tangent function is π . So, the Tangent graph can be extended on both side of x -axis through every interval of π .

Graph of $y = 3 \sin 2x$

We know that $\sin x$ is a periodic function of period 2π .

Step 1: For this function $b = 2$, so the period of $y = 3 \sin 2x$ is $\frac{2\pi}{2} = \pi$. The function will be graphed over the interval $[0, \pi]$.

Step 2: Divides the interval $[0, \pi]$ in eight equal parts to obtain the x-values:

$$0, \frac{\pi}{6}, \frac{\pi}{4}, \frac{\pi}{3}, \frac{\pi}{2}, \frac{2\pi}{3}, \frac{3\pi}{4}, \frac{5\pi}{6}, \pi$$

Step 3: For this, we first construct the table determined by the x-values in Step 2.

| | | | | | | | | | |
|-------------|---|----------------------|-----------------|----------------------|-----------------|-----------------------|------------------|-----------------------|--------|
| x | 0 | $\frac{\pi}{6}$ | $\frac{\pi}{4}$ | $\frac{\pi}{3}$ | $\frac{\pi}{2}$ | $\frac{2\pi}{3}$ | $\frac{3\pi}{4}$ | $\frac{5\pi}{6}$ | π |
| $2x$ | 0 | $\frac{\pi}{3}$ | $\frac{\pi}{2}$ | $\frac{2\pi}{3}$ | π | $\frac{4\pi}{3}$ | $\frac{3\pi}{2}$ | $\frac{5\pi}{3}$ | 2π |
| $\sin 2x$ | 0 | $\frac{\sqrt{3}}{2}$ | 1 | $\frac{\sqrt{3}}{2}$ | 0 | $-\frac{\sqrt{3}}{2}$ | -1 | $-\frac{\sqrt{3}}{2}$ | 0 |
| $3 \sin 2x$ | 0 | 2.61 | 3 | 2.61 | 0 | -2.61 | -3 | -2.61 | 0 |

Step 4: Plot the points $(0, 0)$, $(\frac{\pi}{6}, 2.61)$, $(\frac{\pi}{4}, 3)$, $(\frac{\pi}{3}, 2.61)$, $(\frac{\pi}{2}, 0)$, $(\frac{2\pi}{3}, -2.61)$, $(\frac{3\pi}{4}, -3)$, $(\frac{5\pi}{6}, -2.61)$, $(\pi, 0)$.

Join them with a sinusoidal curve having amplitude 3.

Step 5: Extend the graph by repeating the cycle, from 0 to π .

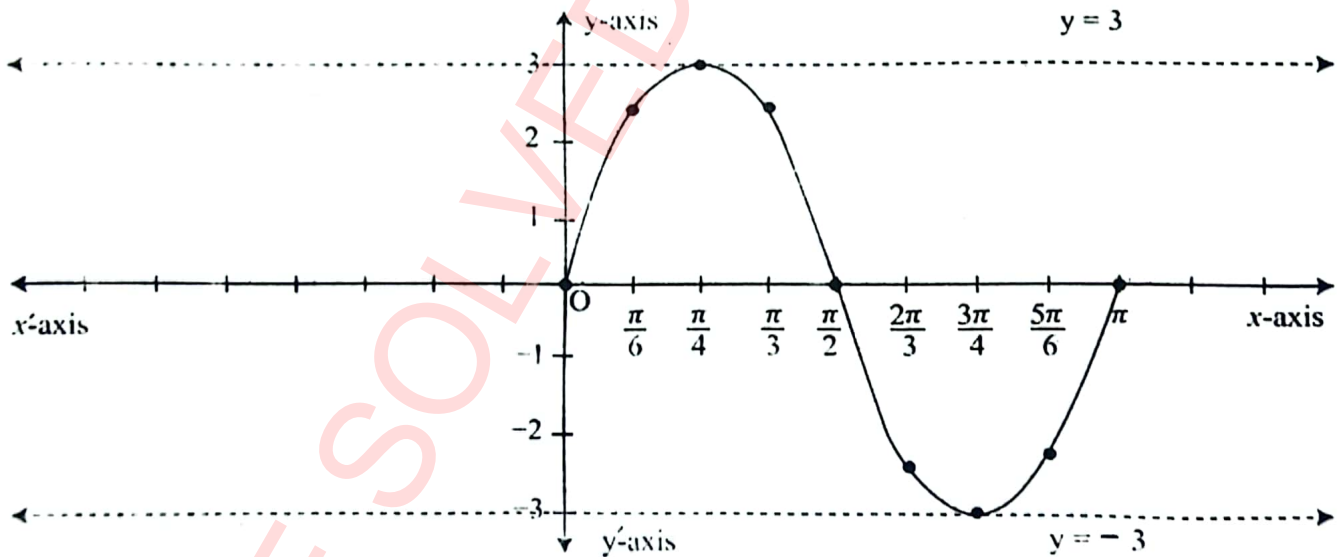

In the similar way, we can draw the graphs for the interval from -2π to 2π .

Characteristics

- Domain = $(-\infty, \infty) = \mathbb{R}$
- Range = $[-3, 3]$
- Period = π
- Amplitude = 3
- Nature = odd function

Key Facts

For $y = a \sin bx$, we know that $-1 \leq \sin bx \leq 1$ and $-a \leq a \sin bx \leq a$. Also, $\sin x$ is a periodic function of period 2π . Therefore, $\sin bx$ is periodic function of period $\frac{2\pi}{b}$. Hence, $a \sin bx$ is periodic function of period $\frac{2\pi}{b}$.



Key Facts

For $y = a \cos bx$, we know that $-1 \leq \cos bx \leq 1$ and $-a \leq a \cos bx \leq a$. Also, $\cos x$ is a periodic function of period 2π . Therefore, $\cos bx$ is periodic function of period $\frac{2\pi}{b}$. Hence, $a \cos bx$ is periodic function of period $\frac{2\pi}{b}$.



Graph of $y = 3 \cos 2x$

We know that $\cos x$ is a periodic function of period 2π .

Step 1: For this function $b = 2$, so the period of $y = 3 \cos 2x$ is $\frac{2\pi}{2} = \pi$. The function will be graphed over the interval $[0, \pi]$.

Step 2: Divides the interval $[0, \pi]$ in eight equal parts to obtain the x-values:

$$0, \frac{\pi}{6}, \frac{\pi}{4}, \frac{\pi}{3}, \frac{\pi}{2}, \frac{2\pi}{3}, \frac{3\pi}{4}, \frac{5\pi}{6}, \pi$$

Step 3: For this, we first construct the table determined by the x-values in Step 2.

| | | | | | | | | | |
|-------------|---|-----------------|-----------------|------------------|-----------------|------------------|------------------|------------------|--------|
| x | 0 | $\frac{\pi}{6}$ | $\frac{\pi}{4}$ | $\frac{\pi}{3}$ | $\frac{\pi}{2}$ | $\frac{2\pi}{3}$ | $\frac{3\pi}{4}$ | $\frac{5\pi}{6}$ | π |
| $2x$ | 0 | $\frac{\pi}{3}$ | $\frac{\pi}{2}$ | $\frac{2\pi}{3}$ | π | $\frac{4\pi}{3}$ | $\frac{3\pi}{2}$ | $\frac{5\pi}{3}$ | 2π |
| $\cos 2x$ | 1 | $\frac{1}{2}$ | 0 | $-\frac{1}{2}$ | -1 | $-\frac{1}{2}$ | 0 | $\frac{1}{2}$ | 1 |
| $3 \cos 2x$ | 3 | 1.5 | 0 | -1.5 | -3 | -1.5 | 0 | 1.5 | 3 |

Step 4: Plot the points $(0, 3), (\frac{\pi}{6}, 1.5), (\frac{\pi}{4}, 0), (\frac{\pi}{3}, -1.5), (\frac{\pi}{2}, -3), (\frac{2\pi}{3}, -1.5), (\frac{3\pi}{4}, 0), (\frac{5\pi}{6}, 1.5), (\pi, 3)$.

Join them with a sinusoidal curve having amplitude 3.

Step 5: The graph can be extended by repeating the cycle.

Characteristics

- Domain = $(-\infty, \infty) = \mathbb{R}$
- Range = $[-3, 3]$
- Period = π
- Amplitude = 3
- Nature = even function

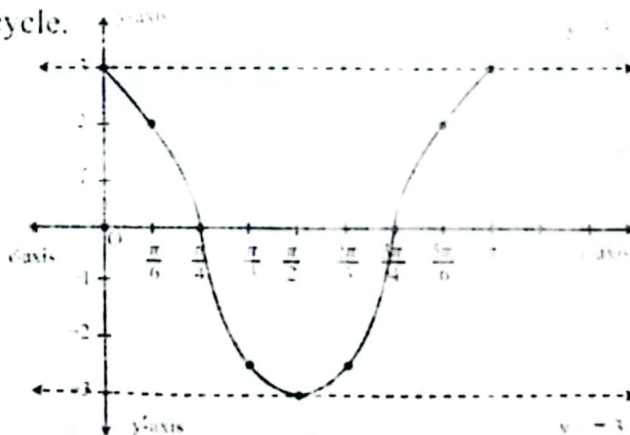

In the similar way, we can draw the graphs for the interval from -2π to 2π .

Graph of $y = \operatorname{cosec} x$

We know that Cosecant function is a reciprocal of the sine function which is a periodic function of period 2π . Therefore, Cosecant is also a periodic function of period 2π .

Step 1: For this function $b = 1$, so the period is 2π . The function will be graphed over the interval $[0, 2\pi]$.

Step 2: Divides the interval $[0, 2\pi]$ in twelve equal parts (from 0 to $\pm\pi$) to obtain the x-values:

$$0, \pm \frac{\pi}{6}, \pm \frac{\pi}{3}, \pm \frac{\pi}{2}, \pm \frac{2\pi}{3}, \pm \frac{5\pi}{6}, \pm \pi$$

Initially, we draw the graph of Cosecant function from 0 to $\pm\pi$.

Step 3: For this, we first construct the table determined by the x-values in Step 2.

| | | | | | | | | | | | | | |
|--------------------------|-----------|-------------------|-------------------|------------------|------------------|------------------|----------|-----------------|-----------------|-----------------|------------------|------------------|----------|
| x | $-\pi$ | $-\frac{5\pi}{6}$ | $-\frac{2\pi}{3}$ | $-\frac{\pi}{2}$ | $-\frac{\pi}{3}$ | $-\frac{\pi}{6}$ | 0 | $\frac{\pi}{6}$ | $\frac{\pi}{3}$ | $\frac{\pi}{2}$ | $\frac{2\pi}{3}$ | $\frac{5\pi}{6}$ | π |
| $\operatorname{Cosec} x$ | $-\infty$ | -2 | -1.15 | -1 | -1.15 | -2 | ∞ | 2 | 1.15 | 1 | 1.15 | 2 | ∞ |

Step 4: Plot the points

$$(-\pi, -\infty), \left(-\frac{5\pi}{6}, -2\right), \left(-\frac{2\pi}{3}, -1.15\right), \left(-\frac{\pi}{2}, -1\right), \left(-\frac{\pi}{3}, -1.15\right), \left(-\frac{\pi}{6}, -2\right), (0, \infty),$$

$$\left(\frac{\pi}{6}, 2\right), \left(\frac{\pi}{3}, 1.15\right), \left(\frac{\pi}{2}, 1\right), \left(\frac{2\pi}{3}, 1.15\right), \left(\frac{5\pi}{6}, 2\right), \text{ and } (\pi, \infty).$$

Join these points by a free hand curve to obtain the graph of $\operatorname{Cosec} x$.

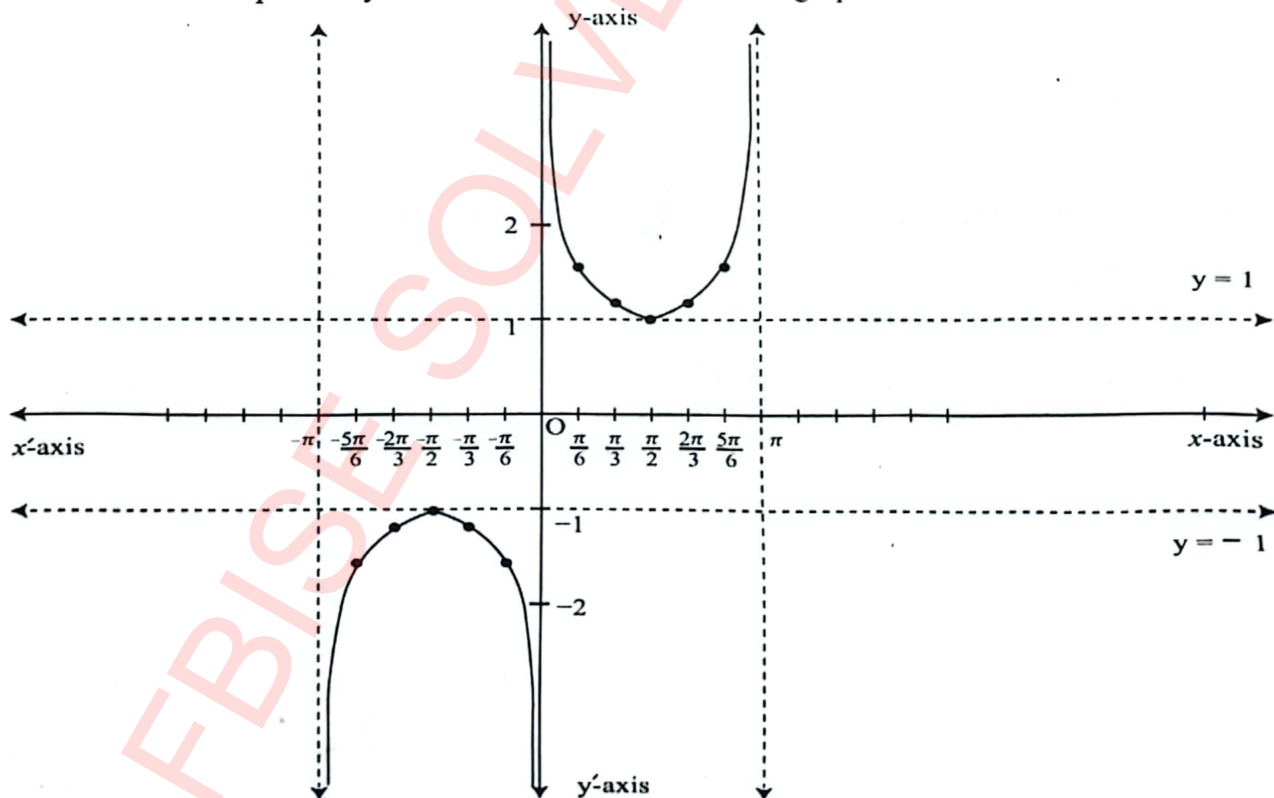

Step 5: Extend the graph by repeating the cycle.

In the similar way, we can draw the graphs for the interval from -2π to 2π .

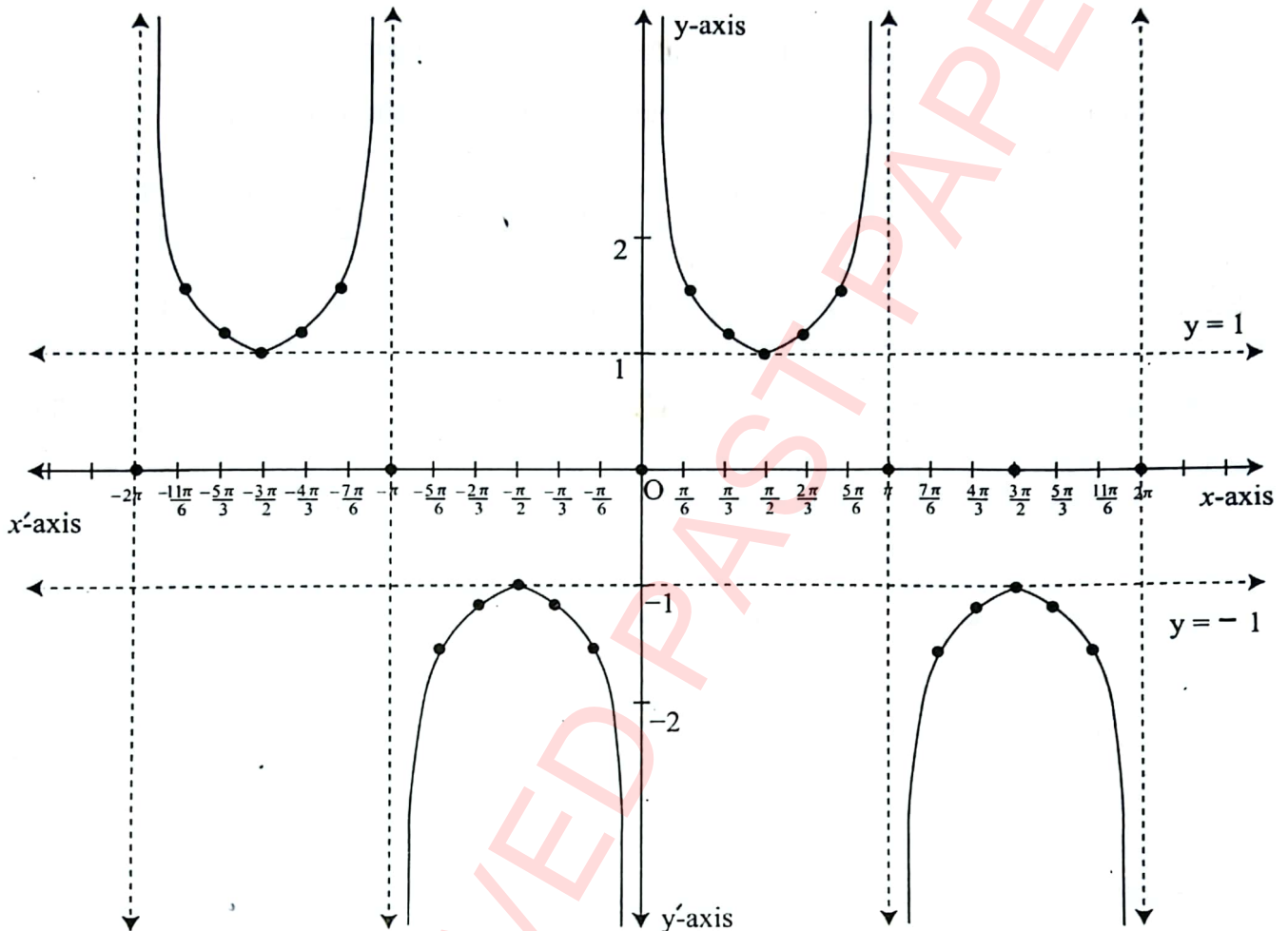

The graph in the interval $[0, 2\pi]$ is called a cycle. Since the period of the cosecant function is 2π . So, the cosecant graph can be extended on both side of x -axis through every interval of 2π .

Characteristics

- Domain = $\{x : x \in \mathbb{R} \text{ and } x \neq n\pi, n \text{ an integer}\}$
- Range = $(-\infty, -1] \cup [1, \infty)$ or $|y| \geq 1$
- Period = 2π
- Amplitude = nil
- Nature = odd function

Graph of $y = \sec x$

We know that Secant function is a reciprocal of the Cosine function which is a periodic function of period 2π . Therefore, Secant is also a periodic function of period 2π .

Step 1: For this function $b = 1$, So the period is 2π . The function will be graphed over the interval $[0, 2\pi]$.

Step 2: Divides the interval $[0, 2\pi]$ in twelve equal parts (From 0 to $\pm\pi$) to obtain the x-values:

$$0, \pm \frac{\pi}{6}, \pm \frac{\pi}{3}, \pm \frac{\pi}{2}, \pm \frac{2\pi}{3}, \pm \frac{5\pi}{6}, \pm \pi$$

Initially, we draw the graph of Cosecant function from 0 to $\pm\pi$.

Step 3: For this, we first construct the table determined by the x-values in Step 2.

| | | | | | | | | | | | | | |
|-----------------|--------|-------------------|-------------------|------------------|------------------|------------------|---|-----------------|-----------------|-----------------|------------------|------------------|-------|
| x | $-\pi$ | $-\frac{5\pi}{6}$ | $-\frac{2\pi}{3}$ | $-\frac{\pi}{2}$ | $-\frac{\pi}{3}$ | $-\frac{\pi}{6}$ | 0 | $\frac{\pi}{6}$ | $\frac{\pi}{3}$ | $\frac{\pi}{2}$ | $\frac{2\pi}{3}$ | $\frac{5\pi}{6}$ | π |
| $\text{Sec } x$ | -1 | -1.15 | -2 | ∞ | 2 | 1.15 | 1 | 1.15 | 2 | ∞ | -2 | -1.15 | -1 |

Step 4: Plot the points $(-\pi, -1), (-\frac{5\pi}{6}, -1.15), (-\frac{2\pi}{3}, -2), (-\frac{\pi}{2}, \infty), (-\frac{\pi}{3}, 2), (-\frac{\pi}{6}, 1.15)$

$$(0, 1), (\frac{\pi}{6}, 1.15), (\frac{\pi}{3}, 2), (\frac{\pi}{2}, \infty), (\frac{2\pi}{3}, -2), (\frac{5\pi}{6}, -1.15), (\pi, -1).$$

Join these points by a free hand curve to obtain the graph of $\sec x$.

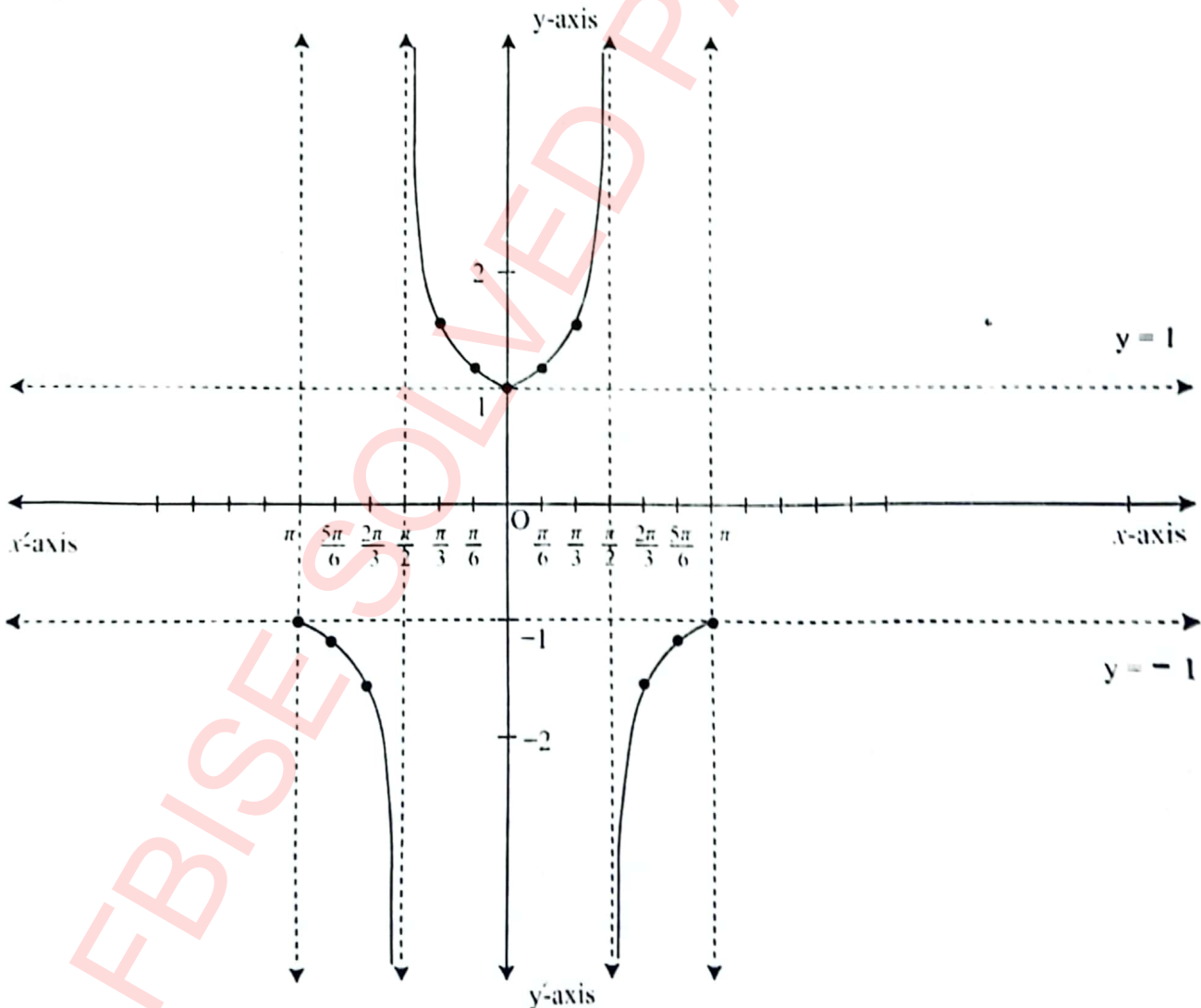

Step 5: The graph can be extended by repeating the cycle.

In the similar way, we can draw the graphs for the interval from -2π to 2π .

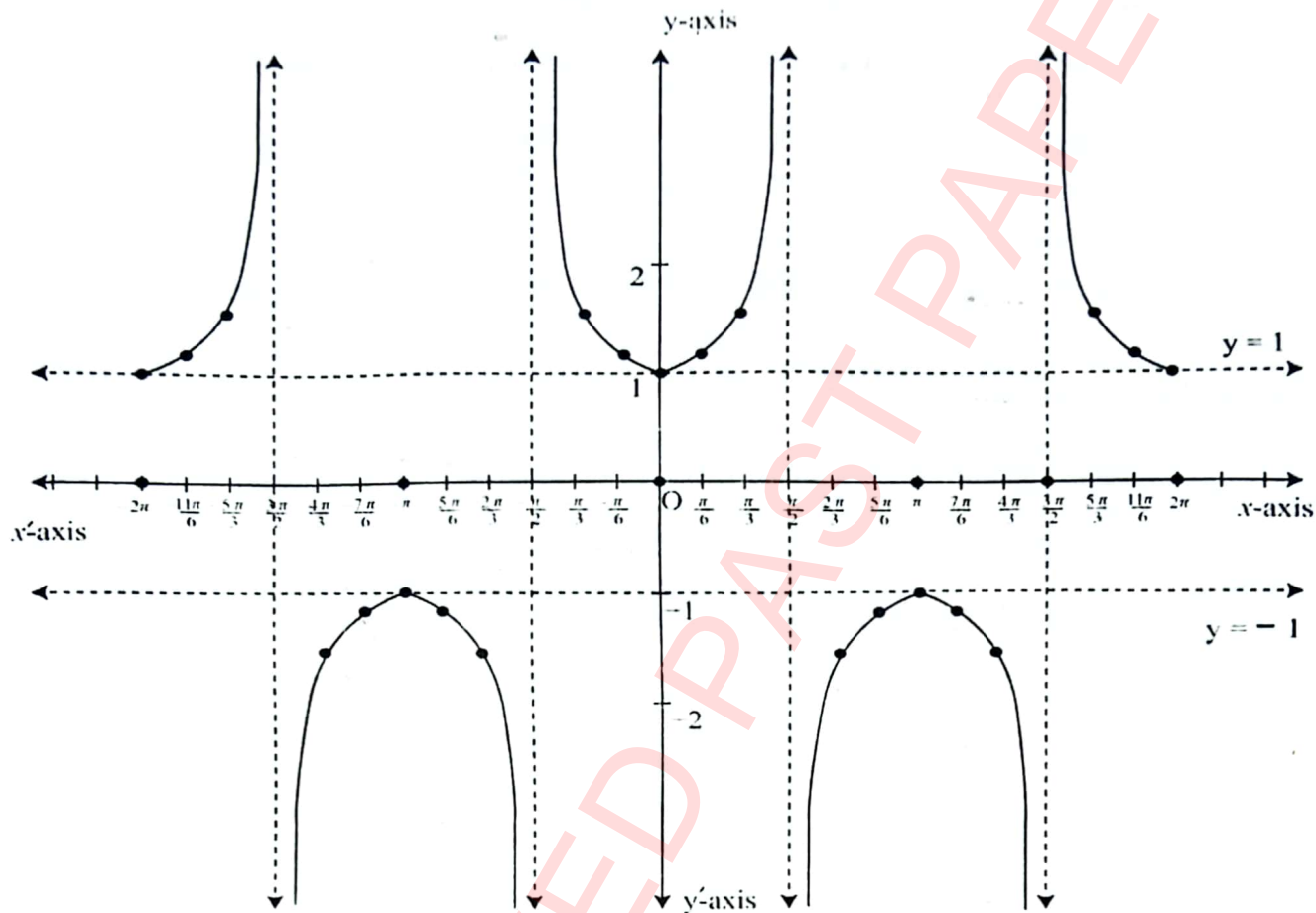

The graph in the interval $[0, 2\pi]$ is called a cycle. Since the period of the cosecant function is 2π . So, the cosecant graph can be extended on both side of x -axis through every interval of 2π .

Characteristics

- Domain = $\{x: x \in \mathbb{R} \text{ and } x \neq \frac{\pi}{2} + n\pi, n \text{ an integer}\}$
- Range = $(-\infty, -1] \cup [1, \infty)$ or $|y| \geq 1$
- Period = 2π
- Amplitude = Nil
- Nature = even function

Graph of $y = \text{Cot } x$

We know that $\text{Cot } x$ is a periodic function of period π .

Step 1: For this function $b = 1$, so the period is π . The function will be graphed over the interval $[0, \pi]$.

Step 2: Divides the interval $[0, \pi]$ in twelve equal parts (from 0 to $\pm\pi$) to obtain the x-values:

$$0, \pm\frac{\pi}{6}, \pm\frac{\pi}{3}, \pm\frac{\pi}{2}, \pm\frac{2\pi}{3}, \pm\frac{5\pi}{6}, \pm\pi$$

Step 3: For this, we first construct the table determined by the x-values in Step 2.

| | | | | | | | | | | | | | |
|----------|-----------|-------------------|-------------------|------------------|------------------|------------------|----------|-----------------|-----------------|-----------------|------------------|------------------|----------|
| x | $-\pi$ | $-\frac{5\pi}{6}$ | $-\frac{2\pi}{3}$ | $-\frac{\pi}{2}$ | $-\frac{\pi}{3}$ | $-\frac{\pi}{6}$ | 0 | $\frac{\pi}{6}$ | $\frac{\pi}{3}$ | $\frac{\pi}{2}$ | $\frac{2\pi}{3}$ | $\frac{5\pi}{6}$ | π |
| $\cot x$ | $-\infty$ | 1.73 | 0.58 | $-\infty$ | -0.58 | -1.73 | ∞ | 1.73 | 0.58 | ∞ | -0.58 | -1.73 | ∞ |

Step 4: Plot the points

$$(-\pi, 0), \left(-\frac{5\pi}{6}, 0.58\right), \left(-\frac{2\pi}{3}, 1.73\right), \left(-\frac{\pi}{2}, 0.58\right), \left(-\frac{\pi}{3}, -1.73\right), \left(-\frac{\pi}{6}, -0.58\right), (0, 0),$$

$$\left(\frac{\pi}{6}, 0.58\right), \left(\frac{\pi}{3}, 1.73\right), \left(\frac{\pi}{2}, \infty\right), \left(\frac{2\pi}{3}, -1.73\right), \left(\frac{5\pi}{6}, -0.58\right), (\pi, 0).$$

Join these points by a free hand curve to obtain the graph of $\cot x$.

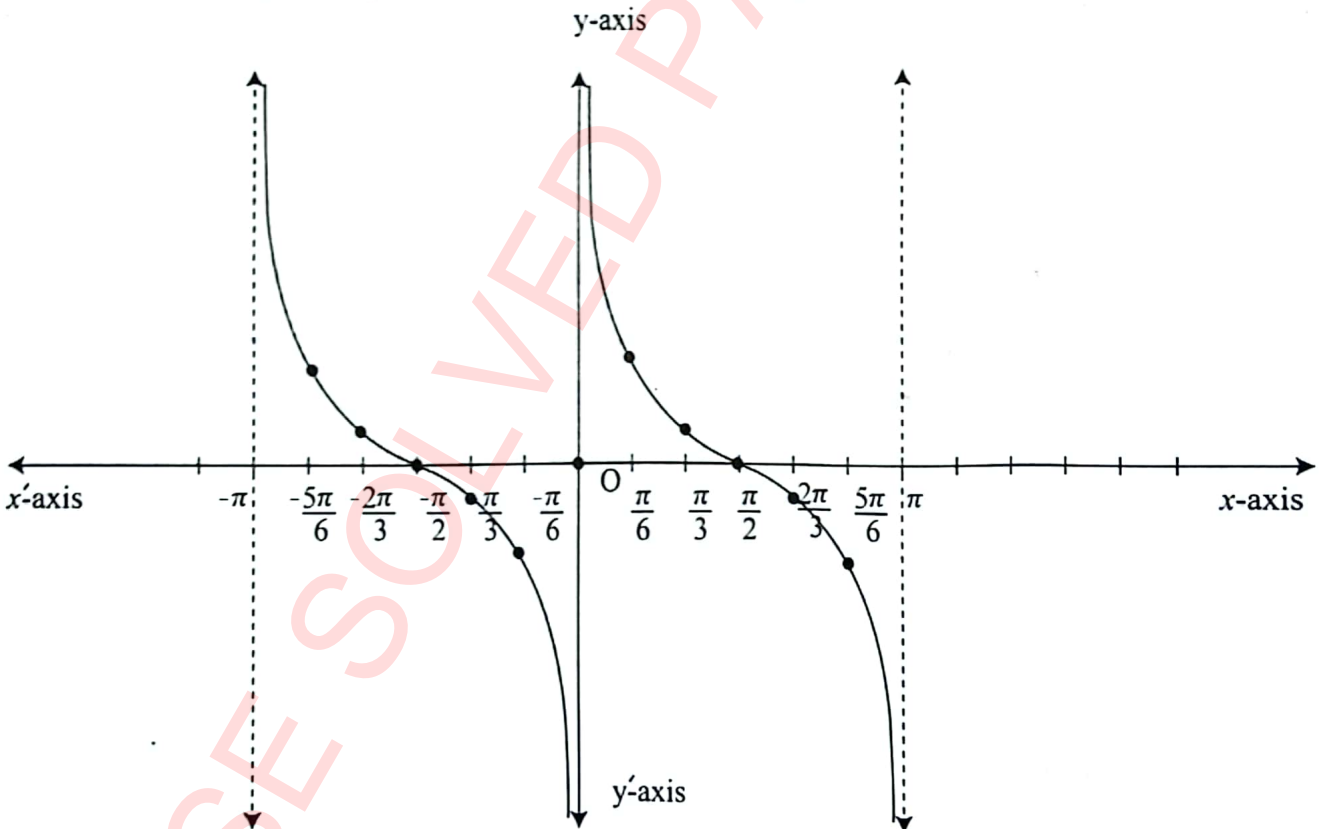

Step 5: Since cotangent is a periodic function of period π . So we shall first draw the graph in the interval $[-\pi, \pi]$. In the similar way, we can draw the graphs for the interval from -2π to 2π .

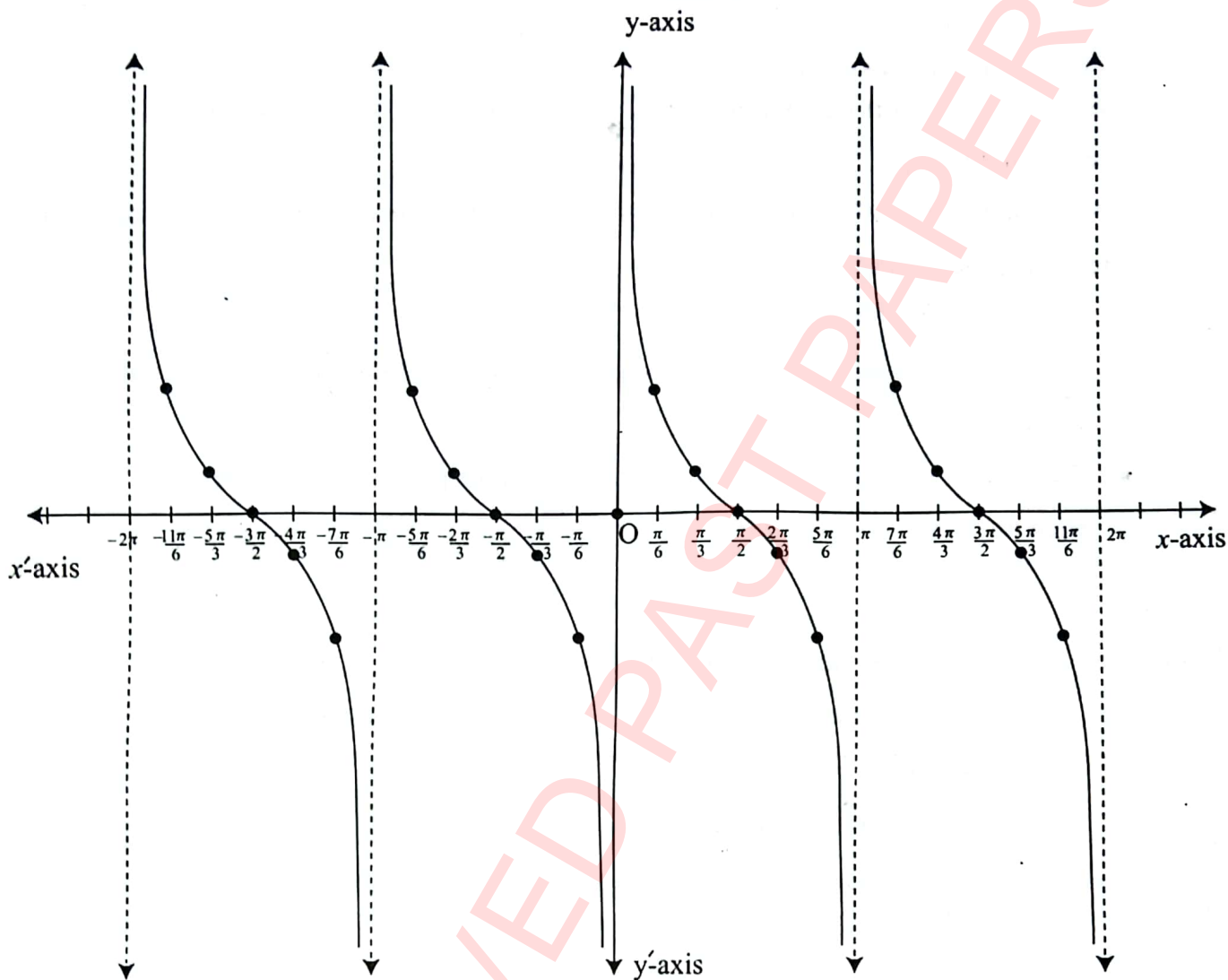

The graph in the interval $[0, \pi]$ is called a cycle. Since the period of the cotangent function is π . So, the cotangent graph can be extended on both side of x -axis through every interval of π .

Characteristics

- Domain = $\{x: x \in \mathbb{R} \text{ and } x \neq n\pi, n \text{ an integer}\}$
- Range = $(-\infty, \infty) = \mathbb{R}$
- Period = π
- Amplitude = nill
- Nature = odd function

9.5 Even and Odd Trigonometric Functions

All functions, including trigonometric functions, can be categorized as even, odd or neither.

- A function is odd if and only if $f(-x) = -f(x)$ and is symmetric (by reflection) with respect to the origin.
- A function is even if and only if $f(-x) = f(x)$ and is symmetric (by 180° rotation) with respect to the y-axis.

Key Facts



- The graph of Sine function is symmetric about the origin therefore, it is an odd function.
- The graph of Cosine function is symmetric with respect to y-axis therefore it is an even function.

Example :

Check whether the following function is odd or even?

Solution: $f(x) = x^3 \cdot \sin x \dots\dots\dots(i)$

Replace 'x' by '-x'

$$\begin{aligned} f(-x) &= (-x)^3 \cdot \sin(-x) \\ &= -(x)^3 \cdot (-\sin(x)) \\ &= x^3 \cdot \sin x = f(x) \end{aligned}$$

As $f(-x) = f(x)$

So (i) is an even function.

Example:

Check whether the following function is odd or even?

(i) $y = 3 \sin x + 4 \cos x$ (ii) $y = \frac{\tan x}{x - \sin x}$

Solution:

(i) $y = 3 \sin x + 4 \cos x$

Replace 'x' by '-x'

$$f(-x) = 3 \sin(-x) + 4 \cos(-x)$$

$$= -3 \sin x + 4 \cos x$$

$$= -(3 \sin x + 4 \cos x)$$

As, $f(-x) \neq f(x)$ or $f(-x) \neq -f(x)$

So, $f(x)$ is neither even nor odd function.

(ii) $y = \frac{\tan x}{x - \sin x}$

Replace 'x' by '-x'

$$f(-x) = \frac{\tan(-x)}{(-x) - \sin(-x)}$$

$$= \frac{-\tan x}{-x + \sin x}$$

$$= \frac{\tan x}{x - \sin x}$$

As, $f(-x) = f(x)$

So, $f(x)$ is an even function.

| Key Facts | | | |
|-----------|----------------------------|---|---------------------------|
| O | $\sin(-x)$ | = | $-\sin x$ |
| E | $\cos(-x)$ | = | $\cos x$ |
| O | $\tan(-x)$ | = | $-\tan x$ |
| O | $\cot(-x)$ | = | $-\cot x$ |
| E | $\sec(-x)$ | = | $\sec x$ |
| O | $\operatorname{cosec}(-x)$ | = | $-\operatorname{cosec} x$ |

9.6 Application

Example:

A Ferris wheel has a diameter of 30 m with a center 17 m above the ground. It makes one complete revolution every 60 seconds.

- Graph one complete period of the graph that models the height in relation to time.
Assume a rider starts at the lowest point.
- Find the equation of the graph using the cosine function.
- What is the height of the rider at 45 seconds?
- At what time or times, the rider is at a height of 15 m?

Solution:

(1)

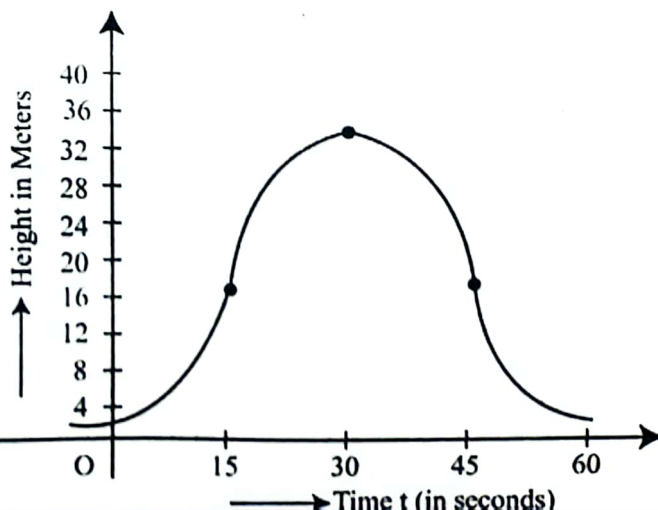

(2) Since

$$y = A \cos(Bx - D) + C$$
$$h(t) = A \cos(Bt) + C \quad (i)$$

Where,

$$|A| = 15 \Rightarrow A = -15 \quad \text{and } \frac{2\pi}{B} \text{ is the period.}$$

$$60 = \frac{2\pi}{B} \Rightarrow B = \frac{\pi}{30} \text{ and } C = 17$$

Putting values in the above equation (i)

$$h(t) = -15 \cos\left(\frac{\pi}{30} t\right) + 17$$
$$= -15 \cos\left(\frac{\pi t}{30}\right) + 17$$

This is the equation which will give us the height of the rider at any time 't'.

(3) Since

$$h(t) = A \cos(Bt) + C$$
$$h(45) = -15 \cos\left(\frac{45\pi}{30}\right) + 17$$
$$= -15 \cos\left(\frac{3\pi}{2}\right) + 17$$
$$= 17 \text{ meters}$$

(4)

$$h(t) = -15 \cos\left(\frac{\pi}{30} t\right) + 17$$
$$15 = -15 \cos\left(\frac{\pi}{30} t\right) + 17$$
$$-2 = -15 \cos\left(\frac{\pi}{30} t\right)$$
$$\cos\left(\frac{\pi t}{30}\right) = \frac{2}{15}$$
$$\frac{\pi t}{30} = \cos^{-1}\left(\frac{2}{15}\right)$$
$$t = \frac{30}{\pi} (1.437)$$

Here,

$$\theta_1 = 1.437, \text{ and } \theta_2 = 2\pi - 1.437 = 4.846$$
$$t_1 = \frac{30}{\pi} (1.437), \text{ and } t_2 = \frac{30}{\pi} (4.846)$$
$$= 13.7 \text{ seconds}$$
$$= 46.3 \text{ seconds}$$

Exercise 9.1

1. Find the maximum and minimum values of the following trigonometric functions.

(i) $y = 2 - 2 \cos \theta$

(ii) $y = \frac{2}{3} - \frac{1}{2} \sin \theta$

(iii) $y = \frac{1}{5} - 2 \sin (3\theta - 7)$

(iv) $y = 7 + \frac{3}{5} \cos (2\theta - 1)$

2. Find the maximum and minimum values of the following reciprocal trigonometric functions.

(i) $y = \frac{1}{4 + 3 \sin \theta}$

(ii) $y = \frac{1}{\frac{1}{2} - 5 \cos \theta}$

(iii) $y = \frac{1}{\frac{1}{3} - 4 \sin(2\theta - 5)}$

(iv) $y = \frac{1}{3 + \frac{2}{5} \sin(5\theta - 7)}$

3. Find domain and range of the following:

(i) $y = 7 \cos 4x$

(ii) $y = \cos \frac{x}{3}$

(iii) $y = \sin \frac{2x}{3}$

(iv) $y = 7 \cot \frac{\pi}{2} x$

(v) $y = 4 \tan \pi x$

(vi) $y = \operatorname{cosec} 4x$

4. Check whether the following functions are odd or even?

(i) $y = \sin x + x \cdot \cos x$

(ii) $y = x^3 \sin x \cdot \cos x$

(iii) $y = \frac{x^2 \cdot \tan x}{x + \sin x}$

(iv) $y = x^3 \cdot \sin x \cdot \cos^{-x}$

(v) $y = \frac{\sin^2 x}{x + \tan x}$

(vi) $y = \frac{\tan x - \sin x}{\sin^3 x}$

(vii) $y = \frac{\sec x}{x + \tan x}$

(viii) $y = x^2 \cdot \sin x \cdot -\cot x$

5. Draw the graph of each of the following functions:

(i) $y = 2 \sin x$

(ii) $y = 2 \cos 3x$

(iii) $y = 2 \tan 2x$

(iv) $y = \cos \frac{x}{2}$

(v) $y = 2 \sin 3x$

(vi) $y = 3 \cos x$

(vii) $y = \cos^2 x$

(viii) $y = \sin^2 x$

(ix) $y = \tan^2 x$

(x) $y = \sin \frac{x}{2}$

6. Find the periods of the following:

(i) $y = 6 \sec (2x - 3)$

(ii) $y = \cos (5x + 4)$

(iii) $y = \cot 4x + \sin \frac{5x}{2}$

(iv) $y = 7 \sin(3x + 3)$ (v) $y = 5 \sin(2x + 3)$ (vi) $y = 2 \tan 3x + 7 \cos x$

7. Draw the graphs of $y = \sin x$ and $y = \sin 2x$ in $[0, 2\pi]$ on the same scale.
8. Draw the graphs of $y = \cos x$ and $y = \cos 2x$ in $[0, 2\pi]$ on the same scale.
9. Solve graphically:
- (i) $\sin x = \cos x$ (ii) $\cos x = x$
- (iii) $\sin x = x$ (iv) $\tan x = x$
10. Alternating current cyclically reverses direction. The maximum voltage is about 180 volts when the standard frequency is 56 Hz (56 cycles per second). The voltage can be modeled by

$$V(t) = a \sin(k(t - d)) + c$$

Determine each of the following:

- Period of 56 Hz AC,
- The value of k ,
- The amplitude of the voltage function,
- Model the voltage with an appropriate transformed Sine function.

I have Learnt

- Finding the domain and range of the trigonometric functions
- Discussing even, and odd functions and the periodicity of trigonometric functions
- Finding the maximum and minimum value of a given function of the type:
 - $a + b \sin \theta$,
 - $a + b \cos \theta$,
 - $a + b \sin(c\theta + d)$,
 - $a + b \cos(c\theta + d)$,
 - The reciprocal of above, where a, b, c , and d are real numbers.
- Graphing and analyzing the trigonometric functions sine, cosine, and tangent to solve problems.
- Explaining the properties of graphs of $\sin \theta$, $\cos \theta$ and $\tan \theta$.
- Applying the concepts of trigonometric functions, identities, graphs, periodicity, even, odd functions, and extreme values to real-world problems such as (distance, elevation, and direction of tall structures, navigation and mapping, lengths of irregular shapes, graphs to visualize and predict patterns in data, frequency and periodic length of Ferris wheel, forces on a see-saw or lever, the ideal angle for solar panel placement)

Review Exercise

1. Mark the correct option in each of the following:

i. If $\cos \theta = -\frac{\sqrt{3}}{2}$ and the terminal arm of angle is in III quadrant. Then $\sin \theta = \dots$

- a. $\frac{1}{2}$ b. $-\frac{1}{2}$ c. $\sqrt{3}$ d. $-\frac{2}{\sqrt{3}}$

ii. The exact value of the trigonometric function $\tan(-15\pi) = \dots$

- a. 0 b. -1 c. 1 d. Undefined

iii. If $2\sin \theta + \frac{1}{2}\text{Cosec } \theta$ and $\theta = 45^\circ$, then the value of the given trigonometric identity is:

- a. $\frac{1}{\sqrt{2}}$ b. $\frac{1}{3}$ c. $\frac{3}{\sqrt{2}}$ d. $\frac{\sqrt{2}}{3}$

iv. If $\sin(270^\circ + \theta) = x$ and the terminal side of an angle ' θ ' is in IV quadrant, then $x = \dots$

- a. $\cos \theta$ b. $-\cos \theta$ c. $\sin \theta$ d. $-\sin \theta$

v. The trigonometric identity $\frac{\sin \alpha + \sin 2\alpha}{1 + \cos \alpha + \cos 2\alpha} = \dots$

- a. $\sin \alpha$ b. $\cos \alpha$ c. $\tan \alpha$ d. $\cot \alpha$

vi. Express $2 \sin 3x \sin 7x$ as a sum or difference:

- a. $\cos 4x - \cos 10x$ b. $\cos 10x - \cos 4x$ c. $\cos 4x + \cos 10x$ d. $\cos 10x + \cos 4x$

vii. Express $\sin 5x + \sin 7x$ as a product:

- a. $2 \sin 6x \cos x$ b. $2 \sin x \cos 6x$ c. $2 \cos 7x \sin 5x$ d. $2 \cos 5x \sin 7x$

viii. The value of $\tan x \cdot \tan\left(\frac{\pi}{3} - x\right) \cdot \tan\left(\frac{\pi}{3} + x\right)$ is:

- a. $2 \cot 3x$ b. $\cot 3x$ c. $3 \tan 3x$ d. $\tan 3x$

ix. If $\tan A = \frac{1}{7}$, and $\tan B = \frac{1}{3}$, Then $\cos 2A$ is equal to:

- a. $\sin B$ b. $\sin 4B$ c. $\sin 3B$ d. $\cos 2B$

x. Whether the function $f(x) = \frac{\sin^3 x}{x^2 + \tan x}$ is:

- a. even b. odd c. neither even nor odd d. both even and odd

xi. The period of $\cos \frac{x}{5}$ is:

- a. 10π b. $\frac{2\pi}{5}$ c. 2π d. 4π

- xii. The trigonometric function $y = \operatorname{cosec} x$ meet at $x = \dots$
a. 30° b. 60° c. 90° d. 120°
- xiii. $2 \cos 5x \cdot \sin 3x = \dots$
a. $\sin 8x - \sin 2x$ b. $\sin 8x + \sin 2x$ c. $\cos 8x + \cos 2x$ d. $\sin 4x - \sin x$
- xiv. The trigonometric functions which are even and having period $= 2\pi$ are:
a. $\sin x$ & $\cos x$ b. $\sec x$ & $\cos x$ c. $\sin x$ & $\operatorname{cosec} x$ d. $\tan x$ & $\cot x$
- xv. If ' f ' is a periodic function and its period is π , then $f(\theta)$ could be equal to:
a. $2 \cos x$ b. $2 \cos 3x$ c. $3 \cos 2x$ d. $\cos 4x$
- xvi. If function $f(x) = \sin 8x$ is a periodic function and its period equals:
a. π b. $\frac{\pi}{4}$ c. 2π d. $\frac{\pi}{2}$
- xvii. If the range of the function $f(\theta) = a \sin(2\theta) + b$, where $a > 0$, is $[3, 5]$, then $3a + 2b = \dots$
a. 11 b. 14 c. 9 d. 5
- xviii. The minimum value of the trigonometric function $f(\theta) = 17 \sin(4\theta)$ is:
a. 4 b. -4 c. -17 d. 17
- xix. If the given figure represent the curve $y = 3 \sin x$, then $|a| + |b| = \dots$

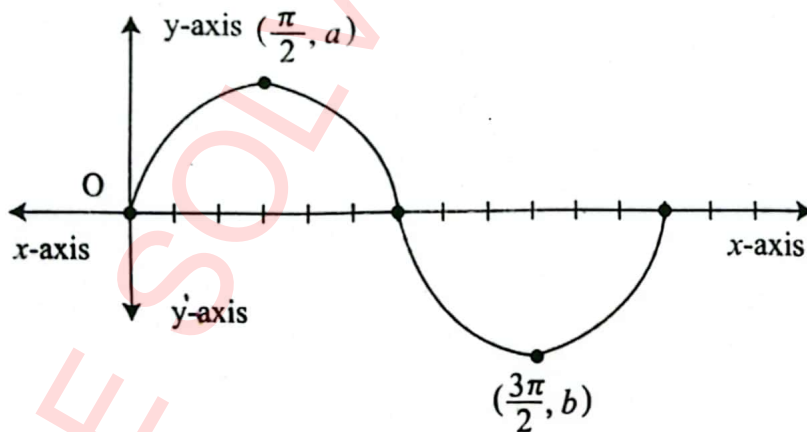

- a. 1 b. 2 c. 3 d. 6
- xx. The maximum value of $7 \cos x + 24 \sin x$ is:
a. 25 b. -25 c. 7 d. 24

2. If $\cos \theta - \sin \theta = \sqrt{2} \sin \theta$, then show that $\cos \theta + \sin \theta = \sqrt{2} \cos \theta$.

3. Verify the following Trigonometric identities:

(a) $\frac{\tan x - \cot x}{\sin x \cdot \cos x} = \sec^2 x - \operatorname{cosec}^2 x$

(b) $\frac{\sec^4 x - \tan^4 x}{\sec^2 x + \tan^2 x} = \sec^2 x - \tan^2 x$

(c) $\frac{\sin t}{1 - \cos t} - \frac{\sin t \cos t}{1 + \cos t} = \operatorname{cosec} t(1 + \cos^2 t)$

4. Prove that:

(i) $\frac{\tan(\alpha + \beta) - \tan \beta}{1 + \tan(\alpha + \beta) \cdot \tan \beta} = \tan \alpha$

(ii) $\frac{1 + \sin 2\theta - \cos 2\theta}{1 + \sin 2\theta + \cos 2\theta} = \tan \theta$

5. If $\cos \alpha + \cos \beta + \cos \gamma = 0$, then prove that:

$$\cos \alpha \cdot \cos \beta \cdot \cos \gamma = \frac{1}{12} (\cos 3\alpha + \cos 3\beta + \cos 3\gamma).$$

6. Prove that:

$$\frac{\cos 7\alpha - \cos 8\alpha}{1 + 2 \cos 5\alpha} = \frac{\sin 7\alpha - \sin 8\alpha}{1 + 2 \sin 5\alpha} = \cos 2\alpha - \cos 3\alpha$$

7. A Ferris wheel is 40 meters in diameter and boarded from a platform that is 4 meter above the ground. The six o'clock position on the Ferris wheel is level with the loading platform. The wheel completes 1 full revolution in 16 minutes. The function $h(t)$ gives a person's height in meters above the ground t minutes after the wheel begins to turn.

a. Find the period, amplitude and vertical shift of $h(t)$.

b. Find a formula for the height function $h(t)$.

c. How high off the ground is a person after 5 minutes?

8. The 'h' (in meters) above the ground of a rider on a Ferris wheel, 't' (in seconds) after the rider begins is given:

$$h(t) = 10 \sin(3(t - 30)) + 12$$

Determine each of the following:

- a. The maximum and minimum heights of the rider above the ground.
 - b. The height of the rider above the ground 30 seconds after start.
 - c. The time required for the Ferris Wheel to complete one complete revolution.
9. The top of the flagpole sways back and forth in high winds. The top sways 8cm to the right (+ 8 cm) and 8 cm to the left (− 8 cm) of its resting position. It moves back and forth 260 every minute. The pole was momentarily at its rest position at $t = 0$, before it started moving to the right.

Find:

- a. the equation of the sinusoidal function that describes the distance the top of the pole is from resting position in terms of time elapsed.
 - b. the domain and range correspond to the situation described.
10. Find the domain, range, and period of the following trigonometric functions:

(i) $7 \sin \frac{\pi}{4} x$

(ii) $2 \sin \frac{x}{3}$

(iii) $\frac{3}{2} \operatorname{cosec} x$

(iv) $5 \sin 3x$

(v) $\frac{1}{2} \sin \frac{2x}{3}$

(vi) $\frac{5}{3} \cos \frac{4x}{3}$

(vii) $3 \sin \pi x$

(viii) $7 \sin 5x$

(ix) $\frac{1}{3} \sec \frac{\pi}{4} x$

(x) $\frac{3}{2} \cot \frac{2\pi}{3} x$

(xi) $9 \cos (3x - 2)$

(xii) $8 - \cos 4x$

(xiii) $7 + 5 \sin (2x - \frac{\pi}{6})$

(xiv) $6 + 4 \cos (2x + \frac{\pi}{3})$

(xv) $\frac{1}{1 - \sin x}$

ANSWERS

Unit 1: Complex Numbers

Exercise 1.1

1. I $-i$ ii. -1 iii. i iv. $2i$ v. -1
2. i. $5 + 6i$ ii. $2 - 2i$ iii. $8 + 0i$ iv. $0 + 10i$ vi. $12 - i$
 vii. $\frac{7}{10} + \frac{9}{10}i$ viii. $\frac{2}{13} - \frac{3}{13}i$
3. i. $\frac{7}{2} - \frac{9}{2}i$ ii. $\frac{7}{25} - \frac{1}{25}i$ iii. $\frac{-1}{5}i$ iv. 0 v. $5 + i$
4. i. $x = -2; y = 2$ ii. $x = 4/3; y = 5/3$ iii. $x = 15/4; y = 5/4$ iv. $x = 7; y = 1$
5. $4 - i$
6. i. $4 + 3i$ ii. $-3i + 8$ iii. $2 - \frac{i}{\sqrt{5}}$ iv. $\frac{-7}{8} - \frac{5i}{2}$
7. i. $\sqrt{265}$ ii. 3 iii. 15 iv. $\sqrt{\frac{13}{5}}$ v. 11

Exercise 1.2

4. $|Z_2| = \frac{16}{\sqrt{13}}$ 6. $\lambda = \frac{-3 \pm i\sqrt{3}}{2}$
8. i. $4x^2 + 4y^2 - 4y - 15 = 0$ ii. $x - y = 0$ iii. $25x^2 + 9y^2 = 225$ iv. $y = 8$
 v. $x = -9$ vi. $-3 \leq y \leq 2$
9. i. $\frac{1}{10} - \frac{1}{5}i$ ii. $\frac{5}{169} + \frac{18}{169}i$ iii. $\frac{19}{53} - \frac{13}{53}i$ iv. $\frac{17}{103} + \frac{36}{25}i$
- v. $-\frac{1579}{1681} - \frac{720}{1681}i$ vi. $-1 - i$

Exercise 1.3

1. i. $(z - 13i)(z + 13i)$ ii. $2(z - 3i)(z + 3i)$ iii. $3(z - 11i)(z + 11i)$
 iv. $(z - \frac{\sqrt{3}}{5}i)(z + \frac{\sqrt{3}}{5}i)$ v. $(2z + 3)(z - \sqrt{5})(z + \sqrt{5})$ vi. $(z - 1)(z - 2)(z + 3)$
 vii. $(z + 3)(z + 4)(z - 5)$ viii. $(z - 2)(z + 5)(z + \frac{3}{2})$ ix. $(z - 8)(z + 1)$
 x. $(z + 1)(4z - 11)$
2. i. $\{3 \pm \sqrt{7}\}$ ii. $\{-5 \pm \sqrt{29}\}$ iii. $\{\frac{-5 \pm \sqrt{249}}{8}\}$ iv. $\{\frac{5 \pm \sqrt{13}}{2}\}$
3. i. $z = \frac{7}{26} + \frac{35}{26}i; w = \frac{-2}{13} + \frac{3}{13}i$ ii. $z = \frac{-166}{29} - \frac{9}{29}i; w = \frac{199}{205} + \frac{177}{205}i$
4. iii. $z = \frac{432}{39} - \frac{431}{39}i; w = \frac{-96}{13} - \frac{40}{13}i$ iv. $z = \frac{23}{53} + \frac{1}{53}i; w = \frac{68}{53} - \frac{80}{53}i$

Exercise 1.4

1. i. $4 \left(\cos \frac{\pi}{3} + i \sin \frac{\pi}{3} \right)$ ii. $2\sqrt{3} \left(\cos \frac{11\pi}{6} + i \sin \frac{11\pi}{6} \right)$ iii. $2\sqrt{2} \left(\cos \frac{5\pi}{4} + i \sin \frac{5\pi}{4} \right)$
 iv. $\sqrt{2} \left(\cos \frac{5\pi}{12} + i \sin \frac{5\pi}{12} \right)$
2. i. i ii. $\frac{-1}{4} - \frac{\sqrt{3}}{4}i$
3. i. $1 - i$ ii. $\frac{-5\sqrt{3}}{2} - \frac{5\sqrt{3}}{2}i$ iii. $-2i$ iv. $-2\sqrt{3} + 2i$ v. $\sqrt{3} + i$
 vi. $\frac{-1}{\sqrt{2}} + \frac{1}{\sqrt{2}}i$ vii. $6.43 + 7.66i$ viii. $-1 + i$ ix. $-2 + 2\sqrt{3}i$ x. $-7 - 7i$

- xi. $10 - 10i$ xii. $2i$ xiii. $1 + i$ xiv. -7 xv. $\sqrt{2} + \sqrt{2}i$ xvi. $3i$ xvii. $\frac{5}{2} + \frac{5\sqrt{3}}{2}i$
4. i. $x + y = 1$ ii. $x^2 + y^2 = 4$ iii. $-\sqrt{3} \leq \frac{y}{x-4} \leq \sqrt{3}$ iv. $0 \leq \sqrt{3} \left(\frac{y-x+12}{x+y-12} \right) \leq 1$
 v. $x^2 + y^2 = 1$ vi. $\sqrt{3}(x^2 - y^2 + 1) - 2xy = 0$
5. i. $\frac{\sqrt{2}}{500}(1 + i)$ ii. $\frac{1}{500}(1 + \sqrt{3}i)$ iii. $\frac{1}{500}(\sqrt{3} + i)$
6. i. $1 - i$ ii. $\frac{-5\sqrt{3}}{2} - \frac{5\sqrt{3}}{2}i$ iii. $-2i$ iv. $-2\sqrt{3} + 2i$ v. $\sqrt{3} + i$
 vi. $\frac{-1}{\sqrt{2}} + \frac{1}{\sqrt{2}}i$ vii. $6.43 + 7.66i$ viii. $-1 + i$ ix. $-2 + 2\sqrt{3}i$ x. $-7 - 7i$
 xi. $10 - 10i$ xii. $2i$ xiii. $1 + i$ xiv. -7 xv. $\sqrt{2} + \sqrt{2}i$ xvi. $3i$ xvii. $\frac{5}{2} + \frac{5\sqrt{3}}{2}i$
7. i. $x + y = 1$ ii. $x^2 + y^2 = 4$ iii. $-\sqrt{3} \leq \frac{y}{x-4} \leq \sqrt{3}$ iv. $0 \leq \sqrt{3} \left(\frac{y-x+12}{x+y-12} \right) \leq 1$
 v. $x^2 + y^2 = 1$ vi. $\sqrt{3}(x^2 - y^2 + 1) - 2xy = 0$
8. i. $\frac{\sqrt{2}}{500}(1 + i)$ ii. $\frac{1}{500}(1 + \sqrt{3}i)$ iii. $\frac{1}{500}(\sqrt{3} + i)$
9. $\theta = \tan^{-1} \left(-\frac{5}{17} \right)$ i. $1 + 4i$ ii. $\frac{1}{4\pi} \tan^{-1} \left(-\frac{5}{17} \right)$
10. i. $\frac{25}{2}(1 + i)$ ii. $-\frac{10}{73}(77 + 38i)$

REVIEW EXERCISE

1. i. c ii. b iii. a iv. d v. b vi. d vii. c viii. d ix. b x. b
2. 10 ii. $\sqrt{2}$ iii. $\sqrt{221}$ iv. $-\frac{9}{34} - \frac{19}{34}i$
3. i. $3(x - 6i)(x + 6i)$ ii. $4(x - \sqrt{10}i)(x + \sqrt{10}i)$
4. $z = x$
5. $z = \frac{-14}{29} + \frac{64}{29}i$ 6. $-478 + 621i$
7. $z = \frac{11 \pm i\sqrt{71}}{4}$ 8. 2

Unit 2: Matrices and Determinants

Exercise 2.1

1. i. 2×3 ii. 3×2 iii. 3×1 iv. 1×4 v. 1×1 vi. 2×2
2. i. rectangular ii. Square iii. column iv. square v. row vi. square

Exercise 2.2

1. i. $\begin{bmatrix} 2 & 7/2 \\ 5/2 & 4 \end{bmatrix}$ ii. $\begin{bmatrix} 1/2 & 1 \\ 1 & 2 \end{bmatrix}$ iii. $\begin{bmatrix} 1 & 1/2 \\ 2 & 1 \end{bmatrix}$ iv. $\begin{bmatrix} -1/3 & -4/3 \\ 1/3 & -2/3 \end{bmatrix}$
2. i. $\begin{bmatrix} 0 & -1/3 & -2/3 \\ 1 & 2/3 & 1/3 \\ 8/3 & 5/3 & 2 \end{bmatrix}$ ii. $\begin{bmatrix} 0 & -1/2 & -1 \\ 3/4 & 0 & -5/4 \\ 4/3 & 5/6 & 0 \end{bmatrix}$ iii. $\begin{bmatrix} 2/3 & 1/2 & 2/5 \\ 2/5 & 1/3 & 2/7 \\ 2/7 & 1/4 & 2/9 \end{bmatrix}$
3. $C = \begin{bmatrix} 1 & 5/3 & 5/2 \\ 5/3 & 2 & 13/5 \\ 5/2 & 13/5 & 3 \end{bmatrix}$
 $C = \begin{bmatrix} -5 & 0 & -9 \\ 0 & -8 & 0 \\ 4 & -4 & 1 \end{bmatrix}$

4. i. $A = \begin{bmatrix} 5 & 7/2 \\ 8 & -11/2 \end{bmatrix}$ ii. $\begin{bmatrix} 1/2 & 1 & 0 \\ 2 & 4 & 1 \end{bmatrix}$ iii. $\begin{bmatrix} 7x \\ x \end{bmatrix}$ where $x \in \mathbb{R}$
 iv. $z = 4, t = 0, x^2 + y^2 = 20$ v. $\alpha = -10; \beta = 9$ vi. $-4, 3$

5. $X^{-1} = \begin{bmatrix} -3/5 & 2/5 & 2/5 \\ 2/5 & -3/5 & 2/5 \\ 2/5 & 2/5 & -3/5 \end{bmatrix}$

6. $\alpha = 9; \beta - 1 A^{-1} = \begin{bmatrix} 1/3 & 1/9 \\ 1/3 & -2/9 \end{bmatrix}$ 13. $X = \begin{bmatrix} 1 & 3 & -1 \\ 1 & 0 & 3 \end{bmatrix} Y = \begin{bmatrix} 1 & 0 & 1 \\ 0 & -1 & -1 \end{bmatrix}$

Exercise 2.3

1. i. 15 ii. 1 iii. -6 iv. $16 + 8i$
 2. i. -17 ii. 27 iii. $1 - 16i$ iv. $-23 - I$
 3. singular ii. Non-singular iii. Non-singular iv. singular
 4. i. $16/23$ ii. -4 iii. $-1 + 5i$ iv. $-\frac{7}{100} - \frac{i}{100}$

5. i. $\begin{bmatrix} 1 & 1 & 0 \\ 3 & 3 & 0 \\ -1 & 2 & -1 \\ 9 & 9 & 3 \\ 5 & -1 & -1 \\ 9 & 9 & 3 \end{bmatrix}$ ii. $\begin{bmatrix} -1 & -4 & 26 \\ 3 & 9 & 9 \\ -1 & -1 & 11 \\ 3 & 9 & 9 \\ 1 & 4 & -17 \\ 3 & 9 & 9 \end{bmatrix}$ iii. $\begin{bmatrix} -4i & 0 & 1 \\ 5 & 0 & 5 \\ 8-i & -1 & -1+2i \\ 5 & 5 & 5 \\ 1 & -i & -i \\ 5 & 0 & 5 \end{bmatrix}$ iv. $\begin{bmatrix} 3 & 2+2i & -2+i \\ 11 & 11 & 22 \\ 0 & 1-i & 1+i \\ -2i & 2 & 4 \\ -2i & -1+i & 5+i \\ 11 & 22 & 44 \end{bmatrix}$

6. $\begin{bmatrix} 1 & -1 & 1 \\ 3 & 2 & 6 \\ 0 & 1 & 0 \\ -1 & 0 & 1 \\ 9 & 9 & 9 \end{bmatrix}$

Exercise 2.4

11. 2. xii. $1/8$

Exercise 2.5

1. i. $\begin{bmatrix} 1 & 3 & 5 \\ 0 & 1 & 33 \\ 0 & 0 & 26 \end{bmatrix}$ ii. $\begin{bmatrix} 1 & 1/2 \\ 0 & 1 \\ 0 & 0 \end{bmatrix}$ iii. $\begin{bmatrix} 1 & -1/2 & 0 \\ 0 & 1 & 8/9 \\ 0 & 0 & 1 \end{bmatrix}$ iv. $\begin{bmatrix} 1 & -2 & 3/2 \\ 0 & 1 & 2/9 \\ 0 & 0 & 1 \end{bmatrix}$

v. $\begin{bmatrix} 1 & 1/3 & 2/3 \\ 0 & 1 & 4/5 \end{bmatrix}$ vi. $\begin{bmatrix} 0 & 1 & 2 \\ 0 & 0 & 0 \\ 0 & 0 & 0 \end{bmatrix}$

2. i. 3 ii. 2 iii. 3 iv. 2
 3. $\frac{1}{2} \begin{bmatrix} -12 & -5 & -3 \\ -4 & -1 & -1 \\ 2 & 1 & 1 \end{bmatrix}$ ii. $\frac{1}{6} \begin{bmatrix} -2 & 0 & 2 \\ 19 & -15 & -16 \\ -6 & 6 & 6 \end{bmatrix}$ iii. $\frac{1}{12} \begin{bmatrix} 0 & -6 & 6 \\ 3 & -9 & 6 \\ 2 & -4 & 6 \end{bmatrix}$

Exercise 2.6

1. i. $\begin{bmatrix} x_3 \\ 2x_3 \\ x_3 \end{bmatrix}$ ii. $\begin{bmatrix} 7/5 x_3 \\ -2/5 x_3 \\ x_3 \end{bmatrix}$ iii. $\begin{bmatrix} x_3 \\ 2x_3 \\ x_3 \end{bmatrix}$ iv. does not exist.

2. i. $\lambda = \frac{-7}{11}; \begin{bmatrix} -10 \\ 13 \\ 13 \\ x_3 \end{bmatrix}$ ii. $\lambda = 2; \begin{bmatrix} -x_3 \\ 1/2 x_3 \\ x_3 \end{bmatrix}$ or $\lambda = -7; \begin{bmatrix} 17x_3 \\ 5x_3 \\ x_3 \end{bmatrix}$

3. i. $\frac{46}{19}; \frac{66}{19}; -\frac{63}{19}$ ii. No solution iii. $5; 0; -3$ iv. $-7; -7; 5$

4. i. $\frac{13}{3}; \frac{26}{7}; \frac{62}{21}$ ii. $\frac{17}{22}; \frac{2}{11}; 0$ iii. $\frac{44}{15}; -\frac{1}{5}; \frac{4}{15}$ iv. $\frac{38}{13}; -\frac{51}{13}; -\frac{42}{13}$
 5. i. 3; 1; 2 ii. $-\frac{1}{7}; \frac{1}{7}; 0$ iii. solution not possible as A is singular iv. $\frac{6}{11}; -\frac{7}{11}; \frac{2}{11}$
 6. $\frac{1}{11}; -\frac{3}{11}; \frac{70}{11}$ ii. $\frac{37}{12}; \frac{7}{3}; \frac{11}{12}$ iii. $\frac{7}{4}; -\frac{23}{2}; -\frac{29}{4}$ iv. 2; 3; 5

7. $\begin{bmatrix} -3/62 & 9/62 & 5/62 \\ 13/31 & -8/31 & -1/31 \\ 19/62 & 5/62 & -11/62 \end{bmatrix} \begin{matrix} 1; 1; 1 \end{matrix}$

8. $\lambda = \pm 4$, no solution; $\lambda \neq \pm 4$ unique solution

REVIEW EXERCISE

1. i. b ii. d iii. d iv. b v. c vi. b vii. d viii. c ix. c x. d
 2. -11, -3, 10; 87
 12. 1/3; no solution

Unit 3: Vectors

Exercise 3.1

1. i. $-7\hat{i} - 5\hat{j}$ ii. $-22\hat{i} - 16\hat{j}$ iii. $-7\hat{i} + 28\hat{j}$ iv. $-\frac{35}{2}\hat{i} - \frac{13}{2}\hat{j}$ v. $-18\hat{i} + 155\hat{j}$
 3. i. $\frac{2}{3}\hat{i} + \frac{2}{3}\hat{j}$ ii. $\vec{u} = -5\hat{i} + 8\hat{j}; \vec{v} = 7\hat{i} - 11\hat{j}$ iii. $8\hat{i} - \hat{j} - \hat{k}$
 4. i. $m = 4/3$ 5. i. $\frac{1}{38}\hat{i} - \frac{1}{38}\hat{j} + \frac{3}{19}\hat{k}$ 7. i. $\lambda = \pm 2\sqrt{11}$ ii. $|\vec{a}| = |\vec{b}|; \vec{a} \neq \vec{b}$
 8. i. $\frac{5}{\sqrt{10}}\hat{j} - \frac{15}{\sqrt{10}}\hat{k}$ ii. $-\frac{3}{\sqrt{257}}\hat{i} + \frac{36}{7\sqrt{257}}\hat{j} - \frac{24}{7\sqrt{257}}\hat{k}$ 9. i. $\frac{7}{5}\hat{i} + \frac{1}{5}\hat{k}$ ii. $-\hat{i} - 12\hat{j} + 5\hat{k}$
 10. i. D(-2, 1) ii. x = 6 and y = 3

Exercise 3.2

1. i. 15 ii. 90 iii. -16 iv. 147 v. 4
 2. i. $\theta = \cos^{-1}\left(\frac{-5}{2\sqrt{13}}\right)$ ii. $\theta = \cos^{-1}\left(\frac{57}{\sqrt{6342}}\right)$ iii. $\theta = \cos^{-1}\left(\frac{-30}{\sqrt{1870}}\right)$
 iv. $\theta = \cos^{-1}\left(\frac{-15}{\sqrt{357}}\right)$ v. $\theta = \cos^{-1}\left(\frac{18}{\sqrt{438}}\right)$
 3. i. $180^\circ - \cos^{-1}\left(\frac{21}{24}\right)$ ii. 90°
 4. i. $\lambda = \frac{29}{43}$
 5. i. $\cos \alpha = \frac{2}{\sqrt{29}}; \cos \beta = \frac{-3}{\sqrt{29}}; \cos \gamma = \frac{4}{\sqrt{29}}$ ii. $\frac{2}{\sqrt{114}}; \frac{21}{\sqrt{62}}$
 6. i. $\pm \frac{5}{\sqrt{3}}\hat{i} \pm \frac{5}{\sqrt{3}}\hat{j} \pm \frac{5}{\sqrt{3}}\hat{k}$
 7. i. -45/2
 8. $\vec{r} = \hat{i} + 2\hat{j} + \hat{k}$
 14. $350/\sqrt{11}$ joules 15. 48 units 16. $50\sqrt{3}$

Exercise 3.3

1. i. (4, -15, -7) ii. (18, -3, -13) iii. (4, -6, 2)
 2. i. (-18, -8, 3) ii. (3, 15, 6)
 3. i. $\frac{\sqrt{78}}{\sqrt{29}\sqrt{26}}$ ii. $\frac{3\sqrt{62}}{\sqrt{29}\sqrt{83}}$
 4. i. $\left(\frac{40}{\sqrt{1533}}, \frac{185}{\sqrt{1533}}, \frac{50}{\sqrt{1533}}\right)$ ii. parallel $\frac{-1}{5}\hat{i} + \frac{1}{10}\hat{j} - \frac{3}{10}\hat{k}$; perpendicular $\frac{26}{5}\hat{i} + \frac{19}{10}\hat{j} - \frac{27}{10}\hat{k}$
 9. $\frac{15\sqrt{15}}{4}$ ii. 6

10. i. $3\sqrt{59}$ ii. $\frac{5}{\sqrt{2}}; \cos^{-1}\left(\frac{-2\sqrt{2}}{33}\right); \cos^{-1}\left(\frac{-7}{3\sqrt{11}}\right); \cos^{-1}\left(\frac{-\sqrt{2}}{3\sqrt{3}}\right)$
 11. $\sqrt{75}$ 14. i. $\sqrt{181}$ ii. $11\sqrt{6}$ 15. i. $4i - 2j - 3k$ ii.
 $\left(\frac{-31}{12}, \frac{1}{12}, \frac{-13}{8}\right)$
 16. $11i + j - 5k$ 17. $-15i + 20j; 21i - 28j - 19k; 6i - 8j - 19k$

Exercise 3.4

1. i. -14 ii. -20
 2. i. 2 ii. -8
 3. ii. $\lambda = -1/2$
 4. i. $\lambda = 2$ 6. i. zero ii. 68 7. i. $27/6$ ii. 3

REVIEW EXERCISE

1. i. d ii. c iii. b iv. b v. c vi. d vii. b viii. b ix. c x. a
 2. i. $2/3$ ii. $-3/20$
 3. $\sqrt{2}$ 4. $\sqrt{19}$ 5. $-11/2$
 8. Ground speed ≈ 235.492 km/h true course $\approx 64.872^\circ$
 9. Speed ≈ 237.816 km/h direction $\approx 107.980^\circ$

Unit 4: Sequences and Series

Exercise 4.1

1. $a_1 = 4, a_2 = 7, a_3 = 10, a_4 = 13, a_{10} = 31, a_{15} = 46$
 2. $a_1 = 2, a_2 = 5, a_3 = 8, a_4 = 11, a_{10} = 29, a_{15} = 44$
 3. $a_1 = \frac{1}{2}, a_2 = \frac{2}{3}, a_3 = \frac{3}{4}, a_4 = \frac{4}{5}, a_{10} = \frac{10}{11}, a_{15} = \frac{15}{16}$
 4. $a_1 = 2, a_2 = 5, a_3 = 10, a_4 = 17, a_{10} = 101, a_{15} = 226$
 5. $a_1 = -1, a_2 = 0, a_3 = 3, a_4 = 8, a_{10} = 80, a_{15} = 95$
 6. $a_1 = 0, a_2 = \frac{3}{5}, a_3 = \frac{4}{5}, a_4 = \frac{15}{17}, a_{10} = \frac{99}{101}, a_{15} = \frac{112}{113}$
 7. $a_1 = 1, a_2 = -\frac{1}{2}, a_3 = \frac{1}{4}, a_4 = -\frac{1}{8}, a_{10} = -\frac{1}{512}, a_{15} = \frac{1}{16384}$
 8. $a_1 = 1, a_2 = 4, a_3 = 9, a_4 = 16, a_{10} = 100, a_{15} = 225$
 9. $a_1 = -4, a_2 = 5, a_3 = -6, a_4 = 7, a_{10} = 13, a_{15} = -18$
 10. $a_1 = -2, a_2 = -6, a_3 = 4, a_4 = -7, a_{10} = -25, a_{15} = 40$
 11. $a_8 = 29$ 12. $a_9 = 56$ 13. $a_7 = 225,$ 14. $a_{12} = -23.5$
 15. $a_{22} = 528,528,$ 16. $a_{20} = \frac{441}{400}$ 17. $a_{43} = 1$ 18. $a_{67} = 67$
 19. $a_n = 2n - 1$ 20. $a_n = 3^n$ 21. $a_n = \sqrt{2n}$ 22. $a_n = 1.1n + 0.1$

Exercise 4.2

1. (i) $a_1 = 4, a_2 = 7, a_3 = 10, a_4 = 13$ (ii) $a_1 = 7, a_2 = 12, a_3 = 17, a_4 = 22$
 (iii) $a_1 = 16, a_2 = 14, a_3 = 12, a_4 = 10$ (iv) $a_1 = 38, a_2 = 34, a_3 = 30, a_4 = 26$
 (v) $a_1 = \frac{3}{4}, a_2 = 1, a_3 = \frac{5}{4}, a_4 = \frac{3}{2}$ (vi) $a_1 = \frac{3}{8}, a_2 = 1, a_3 = \frac{13}{8}, a_4 = \frac{9}{4}$
 2. (i) The next three terms of the sequence are 17, 21, 25
 (ii) The next three terms of the sequence are 20, 23, 26
 (iii) The next three terms of the sequence are $\frac{7}{2}, 21, 25$
 (iv) The next three terms of the sequence are 6.6, 10.6, 14.6. 3. $a_{11} = 0.57$
 4. $a_1 = 19, a_2 = \frac{33}{2}, a_3 = 14, a_4 = \frac{23}{2}$ 5. $a_1 = 8, a_2 = 5, a_3 = 2, a_4 = -1$
 6. $a_{87} = 347$ 7. $a_{20} = 70$ 8. $a_{56} = -\frac{105}{2}$ 9. $d = \frac{a-c}{2ac}$
 10. $a_8 = 240$ feet 11. $S_{20} = \text{Rs } 40000$ 12. $a_8 = 7$

13. (i) 12 (ii) 5 (iii) $4\sqrt{5}$ (iv) $\frac{7y}{2} + 4$ 14. $b = 30$ 15. $x = -9, y = 24$

16. $A_1 = 9, A_2 = 13$ 17. $A_1 = -3, A_2 = -8, A_3 = -13$

Exercise 4.3

1. $S_n = 116$ 2. $S_n = 10100$ 3. $S_n = 10500$ 4. $S_n = 375$ 5. $S_n = 240$ 6. -210 7. $S_n = 240$

8. $S_n = 2550$ 9. $S_n = 2500$ 10. $S_n = 34036$ 11. $S_n = -140$ 12. $S_n = 1155$ 13. 162

14. $\frac{91}{2}$ 15. $S_n = 1060$ 16. $S_n = 387$ 17. $S_n = 816$ 18. $S_n = 162$ 19. $S_n = -220$

20. $a_1 = 7, a_2 = 19, a_3 = 31$ 21. $a_1 = 1, a_2 = 5, a_3 = 9$ 22. $a_1 = 6, a_2 = 36, a_3 = 66$

23. 950 24. 45 25. 12,280,000 26. 38,750

Exercise 4.4

1. The sequence is not geometric

2. The sequence is not geometric 3. The sequence is not geometric

4. The sequence is not geometric 5. $a_1 = 3, a_2 = -6, a_3 = 12, a_4 = -24$

6. $a_1 = 27, a_2 = -\frac{1}{9}, a_3 = \frac{1}{27}, a_4 = -\frac{1}{81}$ 7. $a_1 = 12, a_2 = 6, a_3 = 3, a_4 = \frac{3}{2}$

8. $a_4 = \frac{10}{3}, a_5 = \frac{10}{9}$ 9. $a_4 = 54, a_5 = 162$ 10. $a_4 = \frac{135}{2}, a_5 = \frac{405}{4}$

11. $a_4 = 27, a_5 = 9$ 12. $a_4 = 1, a_5 = 3$ 13. $a_4 = 2, a_5 = 4$

14. $a_3 = 100$ 15. $a_5 = 32$ 16. $a_4 = 56$ 17. $a_5 = 3$

18. $a_6 = -1$ 19. $a_8 = \frac{1}{8}$ 20. 6, 12, 24 21. 2, 4 22. 4, 2, 1, $\frac{1}{2}$

23. 10, 20, 40 24. 14, 28, 56 25. $\frac{1}{2}, 3, 6, 12, 24, 48$ 26. $\frac{1}{256}$ ft 27. 155797

28. 3100.35ft 29. 127 30. 81

Exercise 4.5

1. 176, 2. 93.15 3. 13,28,600 4. 947.11 5. 114681 6. 732

7. 10,656 8. 165, 9. 300 10. 11. 4 12. 0.51 13. 4

14. (i) $\frac{4}{9}$ (ii) 1 (iii) $\frac{5}{9}$ (iv) $\frac{2}{3}$ (v) $\frac{5}{33}$ (vi) $\frac{4}{33}$ 15. 70 16. 800

Exercise 4.6

1. $\frac{1}{27}$ 2. $-\frac{1}{7}$ 3. $-\frac{1}{77}$ 4. $\frac{1}{5n-1}$ 5. $\frac{1}{34-7n}$ 6. $\frac{1}{n+3}$

7. $\frac{1}{14}$ 8. $-\frac{1}{41}$ 9. $\frac{1}{0}$ 11. $\frac{8}{13}$ 12. $\frac{5}{23}, \frac{5}{31}, \frac{5}{39}, \frac{5}{47}$

Exercise 4.7

1. 1.14 2. 0.96 3. 63 4. 45π 5. 1.83 6. $-52,432$ 7. 41, 8. $\frac{10}{11}$ 9. $\sum_{k=1}^{\infty} \frac{k}{k+1}$ 10. $\sum_{k=1}^5 3^k$

11. $\sum_{k=1}^6 (-1)^k 2^k$ 12. $\sum_{k=1}^{\infty} \frac{1}{k(k+1)}$ 14. $2n + 1$ 15. $\frac{n}{6}(2n^2 + 9n + 7)$ 16. $\frac{n}{2}(2n^2 + 7n + 3)$

17. $\frac{n}{2}(6n^2 + 3n - 1)$ 18. $n(n + 1)$ 19. n^2 20. $\frac{n}{2}(3n + 1)$ 21. $\frac{n}{2}(2n^2 + 3n - 5)$

22. $n(n + 2)(n^4 + n^3 + n^2 + 3n - 1)$ 23. $2^n(n - 1) + 1$ 24. $\frac{3ny^{n+1} - 2y^{n+1} - 3ny^n - y^n + 2y + 1}{(y-1)^2}$

25. $\frac{7^{1-n}}{4}(-2n + 7^n - 1)$ 26. $2^{2-n}(-3n - 3) - 2^{1-n} + 14$ 27. $\frac{17}{2}$ 28. $\frac{25}{16}$ 29. $\frac{2x+1}{(1-x)^2}$ 30. $\frac{100}{27}$

Exercise 4.8

1. $n^2 + n + 1$, 2. $\frac{3}{2}n^2 - \frac{3}{2}n + 1$, 3. $3n^2 - 6n + 4$, 4. $\frac{1}{2}n^2 - \frac{1}{2}n + 1$ 5. $\frac{1}{2}n^2 - \frac{1}{2}n + 3$

6. $\frac{1}{2}n^2 - \frac{3}{2}n - 1$ 7. $\frac{n}{3n+1}$, 8. $\frac{n}{5n+1}$, 9. Do yourself 10. $\frac{n-2}{4(n+2)}$, 11. $\frac{n+1}{2(n+2)}$, 12. $\frac{1}{3}$, 13. $\frac{n+2}{15(2n+9)}$

14. Do yourself 15. $\frac{n-1}{n}$

Exercise 4.9

1. 780ft 2. 1065, no because the auditorium has only 1065 seats 3. 491,70044
 4. $a_{20} = 524288$ 5. $a_6 = 0.328$ or 32.8% 6. 30361.4082 7. 964615
 8. 32000 9. $r = \frac{3}{2}$ 10. Rs. 1420418.205 11. Rs. 100625
 12. Rs. 726000 13. Rs. 31000 14. Rs. 356015.99

Miscellaneous Exercise

1. (i) a (ii) c (iii) b (iv) a (v) c (vi) d (vii) b (viii) a (ix) b (x) a (xi) c (xii) b (xiii) a
 (xiv) c (xv) b (xvi) b (xvii) d 2. 3, 5, 7, 9 3. 0, 1, 2, 3 4. 4, 10, 14, ...
 5. $\frac{1}{27} [10^{n+1} - 9n - 10]$ 6. 4, 6, 9 7. 6, 18, 54, 162 8. $n = -1$ 9. $\frac{6}{4+n}$ 10. Do yourself
 11. $n(n+1)^2$ 12. $\frac{1}{12}(n^4 + 11n^2)$

Unit 5: Polynomials

Exercise 5.1

1. (i) 5 (ii) 35 3. No 4. $y+1$ 5. -12 6. $m=6$ 7. Only 1 is a zero of P(x)
 8. 2, -3, $\frac{-1}{2}$ 9. $(x-4)(x^2+3x-2)+3$ 10. $x^2+10x+24$

Exercise 5.2

1. $(y+1)(y-3)(y+2)$ 2. $(x-1)(x+1)(2x-1)$ 3. $(x-2)(x+3)(2x+3)$ 4. $(x-3)(3x^2+4x+12)$
 5. $(t-1)(t^2+2t+5)$ 6. Other two factors are $(x-6)$ and $(2x+1)$ 7. $(2x-1)(x-5)(x-2)$
 8. $(2x+1)(2x^2+x+36)$

Exercise 5.3

1. 5cm by 12cm by 2cm 2. 650 3. 6 units by 8 units by 3 units 4. 9 units by 11 units by 25 units
 5. Length of one side of square ABFG is $x+4$. Area = $(x+4)^2$. The length of rectangle ACED = $3x+7$.
 6. $y+1, a-2$

REVIEW EXERCISE

1. (i) (d) (ii) (a) (iii) (b) (iv) (a) (v) (b) (vi) (c) (vii) (b) (viii) (c)
 2. $16y^2+4y+4$ 3. $25y^2+10y+4$ 4. Yes 5. $5x^3-13x^2-34x+24$
 6. -48 7. $x+4$ 8. $y+5$

Unit 6: Permutation, & Combination

Exercise 6.1

1. i. 362880 ii. 7920 iii. $11/63$ iv. $n-1$ v. $7/90$
 2. i. $14!/10!$ ii. $9!/4! \times 16$ iii. $\frac{(n+1)!}{(n-2)!}$ iv. $\frac{(n-3)!}{n(n-4)(n-4)!}$
 5. i. 6 ii. 6 7. i. 31 ii. 8 iii. 3 iv. 10 v. 6 vi. 121 vii. 11 viii. 2 ix. 4

Exercise 6.2

2. i. 7 ii. 13 iii. 5 iv. 8 v. 19 vi. 6 vii. 9 viii. 8 ix. 10
 3. i. 3 ii. 5 iii. 2 iv. 8 v. 2 vi. 3 vii. 41
 4. 60 5. 60480 6. 1296 7. 18 8. 2880 9. 1260 10. 720; 120
 11. 45360 12. 36 13. 42 14. 210 15. 2520 16. 360
 17. 72 18. 48 19. 30,240 20. 86400 22. HOELRA 22. MULTAN

Exercise 6.3

2. i. 13 ii. 22 iii. 51 iv. 6 v. 11 vi. 5 3. i. 3 ii. 3 iii. 3 iv. 5
 4. i. 9; 3 ii. 62; 27 iii. 10; 5 iv. 14; 4
 5. i. 4368 ii. 3003 6. 55 7. i. 120 ii. 186 iii. 186 8. i. 45 ii. 120
 9. ${}^n C_2 - n$ 10. 14400 11. 7 12. 300500200 13. 63 14. 6272

REVIEW EXERCISE

1. i. b ii. c iii. a iv. a v. d vi. c vii. b viii. d ix. c x. c
 2. 24 3. 100 4. 600 5. 360 6. 32,659,200

Unit 7: Mathematical Induction and Binomial Theorem

Exercise 7.2

10. -5940 11. 14 13. 12, 2 19. 21 times 20. 56 times

Exercise 7.3

7. $\frac{(-1)^n}{2}(n^2 + 7n + 8)x^n$

Exercise 7.4

1. 1, 8, 4, 7 2. a. 5 b. 2 3. 1
 4. a. 5, 25 b. 3, 33 c. 1, 01 8. 8 9. 8

REVIEW EXERCISE

1. i. d ii. c iii. d iv. d v. b vi. c vii. b viii. a ix. b x. b
 3. 232 6. 78

Unit 8: Fundamentals of Trigonometry

EXERCISE 8.1

1. (i) $\cos(180^\circ + 60^\circ) = -\cos 60^\circ$, $\cos(180^\circ - 60^\circ) = -\cos 60^\circ$, $\sin(180^\circ + 60^\circ) = -\sin 60^\circ$,
 $\sin(180^\circ - 60^\circ) = \sin 60^\circ$, $\tan(180^\circ + 60^\circ) = \tan 60^\circ$, $\tan(180^\circ - 60^\circ) = -\tan 60^\circ$
 (ii) $\cos(90^\circ + 60^\circ) = -\sin 60^\circ$, $\cos(90^\circ - 60^\circ) = \sin 60^\circ$, $\sin(90^\circ + 60^\circ) = \cos 60^\circ$,
 $\sin(90^\circ - 60^\circ) = \cos 60^\circ$, $\tan(90^\circ + 60^\circ) = -\cot 60^\circ$, $\tan(90^\circ - 60^\circ) = \cot 60^\circ$
 (v) $\cos\left(2\pi + \frac{\pi}{6}\right) = \cos\left(\frac{\pi}{6}\right)$, $\cos\left(2\pi - \frac{\pi}{6}\right) = \cos\left(\frac{\pi}{6}\right)$, $\sin\left(2\pi + \frac{\pi}{6}\right) = \sin\left(\frac{\pi}{6}\right)$,
 $\sin\left(2\pi - \frac{\pi}{6}\right) = -\sin\left(\frac{\pi}{6}\right)$, $\tan\left(2\pi + \frac{\pi}{6}\right) = \tan\left(\frac{\pi}{6}\right)$, $\tan\left(2\pi - \frac{\pi}{6}\right) = -\tan\left(\frac{\pi}{6}\right)$
 2. (a) $\cos 15^\circ = \frac{\sqrt{6} + \sqrt{2}}{4}$ (b) $\cos 165^\circ = -\frac{\sqrt{6} + \sqrt{2}}{4}$ (c) $\cos 345^\circ = \frac{\sqrt{6} - \sqrt{2}}{4}$ (d) $\sin 75^\circ = \frac{\sqrt{6} - \sqrt{2}}{4}$
 3. (a) $\cos 120^\circ = -\frac{1}{2}$ (b) $\sin 120^\circ = \frac{\sqrt{3}}{2}$, $\tan 120^\circ = -\sqrt{3}$ (c) $\cos 75^\circ = \frac{\sqrt{3} - 1}{2\sqrt{2}}$
 (d) $\cos 105^\circ = \frac{1 - \sqrt{3}}{2\sqrt{2}}$ (e) $\cos 285^\circ = \frac{\sqrt{3} - 1}{2\sqrt{2}}$ (f) $\sin 15^\circ = \frac{\sqrt{3} - 1}{2\sqrt{2}}$
 4. (i) $\cos 9\theta$ (ii) $\cos 5\theta$ (iii) $\sin \frac{\theta}{2}$ (iv) $\sin 92^\circ$ (v) $\tan 30^\circ$ (vi) $\tan 2\pi$
 5. $\cos(\alpha + \beta) = \frac{16}{65}$, $\cos(\alpha - \beta) = \frac{56}{65}$
 6. (i) $\sin(\alpha - \beta) = \frac{304}{425}$ (ii) $\cos(\alpha - \beta) = \frac{93}{85}$ (iii) $\tan(\alpha - \beta) = \frac{304}{465}$
 7. (i) $\sin(\alpha + \beta) = \frac{56}{65}$ (ii) $\cos(\alpha + \beta) = -\frac{33}{65}$ (iii) $\tan(\alpha + \beta) = -\frac{56}{33}$
 8. (i) $\csc(\alpha + \beta) = \frac{65}{16}$ (ii) $\sec(\alpha + \beta) = \frac{65}{63}$ (iii) $\cot(\alpha + \beta) = \frac{63}{16}$
 9. (i) $\sin(\alpha + \beta) = -\frac{7}{5\sqrt{2}}$, $\sin(\alpha - \beta) = \frac{1}{5\sqrt{2}}$ (ii) $\cos(\alpha + \beta) = -\frac{1}{5\sqrt{2}}$, $\cos(\alpha - \beta) = \frac{7}{5\sqrt{2}}$

(iii) $\tan(\alpha + \beta) = 7$, $\tan(\alpha - \beta) = \frac{1}{7}$

13. (i) $12 \sin \theta - 5 \cos \theta = r \sin(\theta + \varphi)$ where $r = 13$ and $\varphi = \tan^{-1}\left(-\frac{5}{12}\right)$

(ii) $3 \sin \theta + 4 \cos \theta = r \sin(\theta + \varphi)$ where $r = 5$ and $\varphi = \tan^{-1}\left(\frac{4}{3}\right)$ (iii) Do yourself.

14. (a) $\alpha = 45^\circ$ (b) $\sin \theta = \frac{7}{\sqrt{58}}$, $\cos \theta = \frac{3}{\sqrt{58}}$ (c) 0.9285 (d) 22°

EXERCISE 8.2

1. $\cos 2\theta = -\frac{7}{25}$, $\sin 2\theta = -\frac{24}{25}$, III quadrant

2. $\sin 2\alpha = -2y\sqrt{1-y^2}$, $\cos 2\alpha = 1-2y^2$, $\tan 2\alpha = -\frac{2y\sqrt{1-y^2}}{1-2y^2}$ 3. $\cos 15^\circ = \sqrt{\frac{1+\cos 30^\circ}{2}} = 0.966$

4. (i) $\sin 2\theta = \frac{24}{25}$, $\cos 2\theta = -\frac{7}{25}$, $\tan 2\theta = -\frac{24}{7}$, $\sin \frac{\theta}{2} = \frac{1}{\sqrt{5}}$, $\cos \frac{\theta}{2} = \frac{2}{\sqrt{5}}$, $\tan \frac{\theta}{2} = \frac{1}{2}$

(ii) $\sin 2\theta = -\frac{120}{169}$, $\cos 2\theta = -\frac{119}{169}$, $\tan 2\theta = \frac{120}{119}$, $\sin \frac{\theta}{2} = \frac{2}{\sqrt{13}}$, $\cos \frac{\theta}{2} = \frac{3}{\sqrt{13}}$, $\tan \frac{\theta}{2} = \frac{2}{3}$

(iii) $\sin 2\theta = \frac{336}{625}$, $\cos 2\theta = \frac{527}{625}$, $\tan 2\theta = \frac{336}{527}$, $\sin \frac{\theta}{2} = \frac{1}{5\sqrt{2}}$, $\cos \frac{\theta}{2} = \frac{7}{5\sqrt{2}}$, $\tan \frac{\theta}{2} = \frac{1}{7}$

(iv) $\sin 2\theta = \frac{4}{5}$, $\cos 2\theta = -\frac{3}{5}$, $\tan 2\theta = -\frac{4}{3}$, $\sin \frac{\theta}{2} = \sqrt{\frac{\sqrt{5}-1}{2\sqrt{5}}}$, $\cos \frac{\theta}{2} = \sqrt{\frac{\sqrt{5}+1}{2\sqrt{5}}}$, $\tan \frac{\theta}{2} = \sqrt{\frac{\sqrt{5}-1}{\sqrt{5}+1}}$

(v) $\sin 2\theta = -1$, $\cos 2\theta = 0$, $\tan 2\theta = \text{undefined}$, $\sin \frac{\theta}{2} = \sqrt{\frac{\sqrt{2}-1}{2\sqrt{2}}}$, $\cos \frac{\theta}{2} = \sqrt{\frac{\sqrt{2}+1}{2\sqrt{2}}}$, $\tan \frac{\theta}{2} = \sqrt{\frac{\sqrt{2}-1}{\sqrt{2}+1}}$

(vi) $\sin 2\theta = -\frac{\sqrt{3}}{2}$, $\cos 2\theta = \frac{1}{2}$, $\tan 2\theta = -\sqrt{3}$, $\sin \frac{\theta}{2} = \frac{\sqrt{2+\sqrt{3}}}{2}$, $\cos \frac{\theta}{2} = \frac{\sqrt{2-\sqrt{3}}}{2}$, $\tan \frac{\theta}{2} = \sqrt{\frac{2+\sqrt{3}}{2-\sqrt{3}}}$

5. (i) $\sin \theta = \frac{3}{5}$, $\cos \theta = \frac{4}{5}$, $\tan \theta = \frac{3}{4}$ (ii) $\sin \theta = \frac{3}{5}$, $\cos \theta = -\frac{4}{5}$, $\tan \theta = -\frac{3}{4}$

(iii) $\sin \theta = \frac{8}{17}$, $\cos \theta = \frac{15}{17}$, $\tan \theta = \frac{8}{15}$ (iv) $\sin \theta = \frac{7}{13\sqrt{2}}$, $\cos \theta = -\frac{17}{13\sqrt{2}}$, $\tan \theta = -\frac{7}{17}$

6. (i) $\frac{1}{4}$ (ii) $\frac{\sqrt{3}}{2}$ (iii) $\frac{1}{\sqrt{2}}$ (iv) $\frac{\sqrt{3}}{2}$ (v) $\frac{1}{\sqrt{3}}$

7. (i) $\frac{1-\cos 4\alpha}{2}$ (ii) $\frac{1}{16}[1-\cos 2\alpha-\cos 4\alpha+\cos 2\alpha \cos 4\alpha]$ (iii) $\frac{1}{128}[3-4\cos 4\alpha+\cos 8\alpha]$

EXERCISE 8.3

1. (i) $2[\sin 26x + \sin 6x]$ (ii) $5[\cos 16y + \cos 4y]$ (iii) $\sin 8t - \sin 2t$

(iv) $3[\sin 15x + \sin 5x]$ (v) $\frac{1}{2}[\cos 6u - \cos 4u]$ (vi) $\cos 120^\circ - \cos 80^\circ$

(vii) $\frac{1}{2}[\sin 40^\circ - \sin 6^\circ]$ (viii) $\sin 104^\circ - \sin 8^\circ$ (ix) $\cos 60^\circ - \cos 90^\circ$

(x) $2[\sin u + \sin v]$ (xi) $\sin 2u - \sin 2v$

2. (i) $2 \sin 50^\circ \cos 20^\circ$ (ii) $2 \cos 45^\circ \sin 31^\circ$ (iii) $-2 \sin 35^\circ \sin 23^\circ$

(iv) $2 \cos \frac{p}{2} \cos \frac{q}{2}$ (v) $-2 \sin 15^\circ \cos 5^\circ$

REVIEW EXERCISE

1. (i) a (ii) b (iii) c (iv) d (v) b (vi) a
 (vii) c (viii) d (ix) b (x) c (xi) d (xii) a
2. (i) $\frac{56}{65}$ (ii) $-\frac{56}{33}$ (iii) $-\frac{16}{63}$
3. (i) $\sin(\beta + 45^\circ)$ or $\cos(\beta - 45^\circ)$ (ii) $\cos 45^\circ$ or $\sin 135^\circ$
4. (i) $\tan 60^\circ = 1.732$ (ii) $\cos 90^\circ = 0$ 5. $\tan \theta = \frac{1}{2}$ 9. 1

Unit 9: Trigonometric Functions

1. i. Maximum value (M) = 4 ; Minimum value (m) = 0
 ii. Maximum value (M) = $\frac{7}{6}$; Minimum value (m) = $\frac{1}{6}$
 iii. Maximum value (M) = $\frac{11}{5}$; Minimum value (m) = $-\frac{9}{5}$
 iv. Maximum value (M) = $\frac{38}{5}$; Minimum value (m) = $\frac{32}{5}$
2. i. Maximum value (M) = 1 ; Minimum value (m) = $\frac{1}{7}$
 ii. Maximum value (M) = $\frac{2}{11}$; Minimum value (m) = $-\frac{2}{9}$
 iii. Maximum value (M) = $\frac{3}{13}$; Minimum value (m) = $-\frac{3}{11}$
 iv. Maximum value (M) = $\frac{5}{13}$; Minimum value (m) = $\frac{5}{17}$
3. i. Domain = $Dy =] -\infty, \infty [= R$; Range = $Ry = [-7, 7]$
 ii. Domain = $Dy =] -\infty, \infty [= R$; Range = $Ry = [-1, 1]$
 iii. Domain = $Dy =] -\infty, \infty [= R$; Range = $Ry = [-1, 1]$
 iv. Domain = $Dy =] -\infty, \infty [= R$; Range = $Ry = 0$
 v. Domain = $Dy =] -\infty, \infty [= R$; Range = $Ry = 0$
 vi. Domain = $Dy =] -\infty, \infty [= R$; Range = $Ry = [-6, 6]$
4. i. odd ii. even iii. even iv. even
 v. even vi. even vii. odd viii. odd

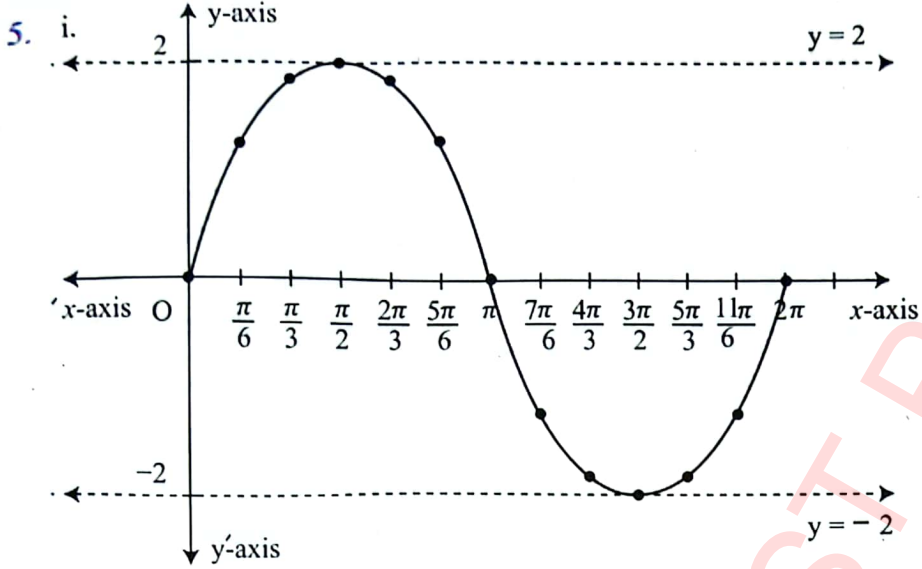

Characteristics

- Domain = $(-\infty, \infty) = \mathbb{R}$
- Range = $[-2, 2]$
- Period = 2π
- Amplitude = 2
- Nature = odd function

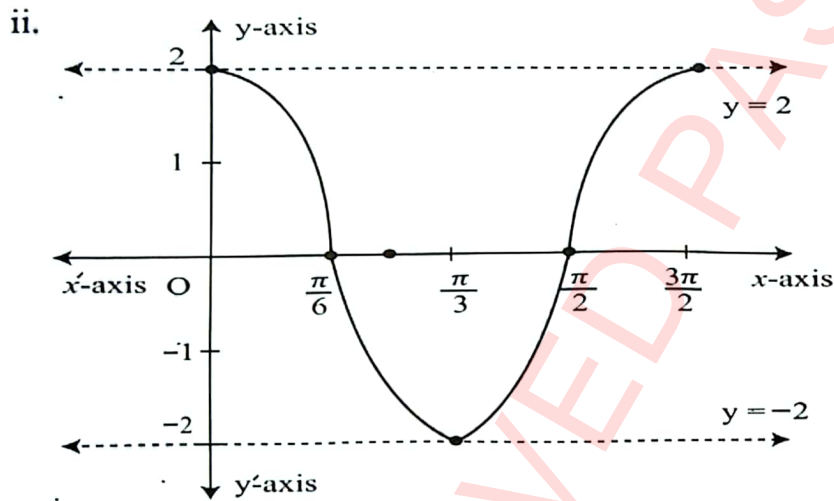

Characteristics

- Domain = $(-\infty, \infty) = \mathbb{R}$
- Range = $[-2, 2]$
- Period = $\frac{2\pi}{3}$
- Amplitude = 2
- Nature = even function

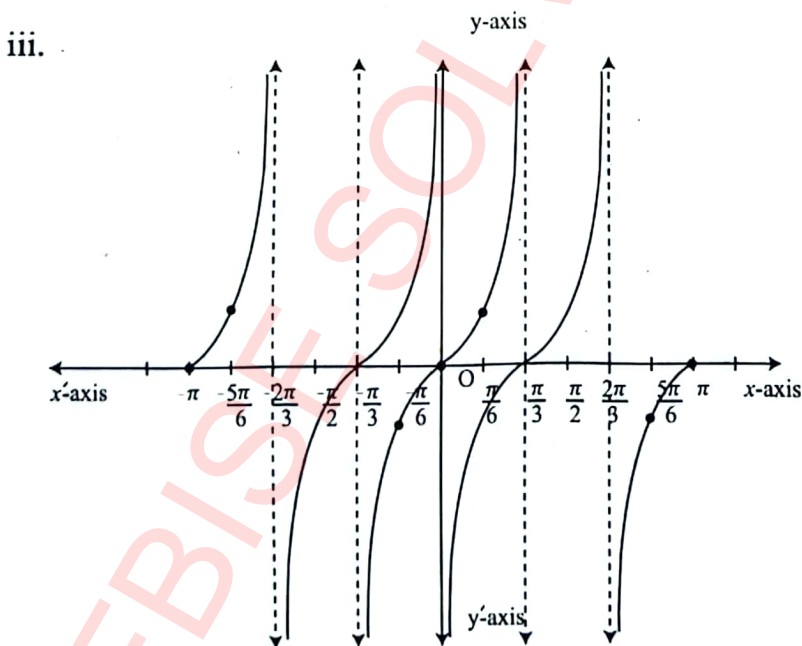

Characteristics

- Domain = $\frac{\pi n}{2} < x < \frac{\pi}{4} + \frac{\pi n}{2}$
- Range = $] -\infty, \infty [$
- Period = $\frac{\pi}{2}$
- Amplitude = nil
- Nature = odd function

iv.

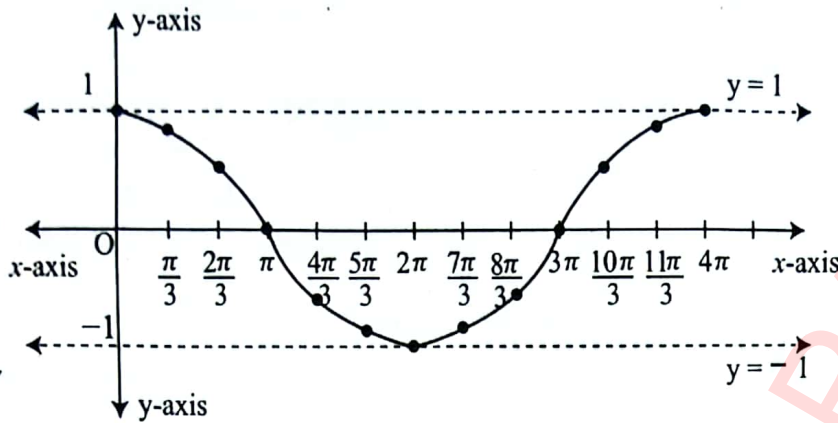

Characteristics

- Domain = $(-\infty, \infty) = \mathbb{R}$
- Range = $[-1, 1]$
- Period = 4π
- Amplitude = 1
- Nature = even function

v.

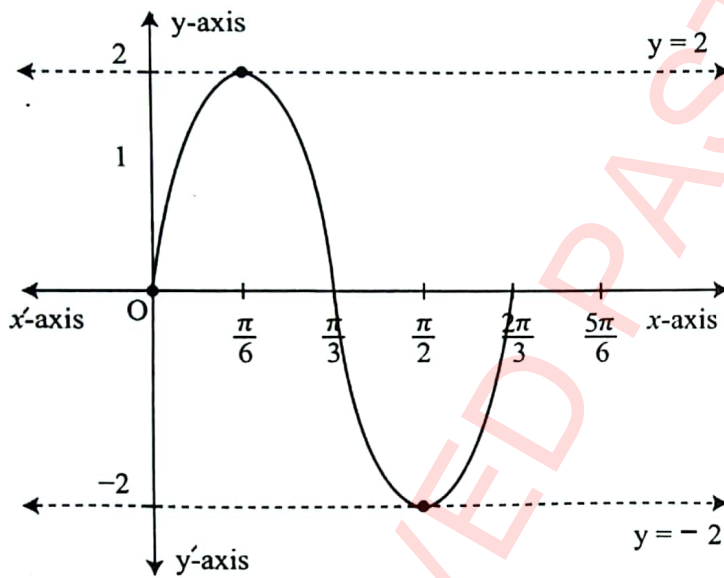

Characteristics

- Domain = $(-\infty, \infty) = \mathbb{R}$
- Range = $[-2, 2]$
- Period = $\frac{2\pi}{3}$
- Amplitude = 2
- Nature = odd function

vi.

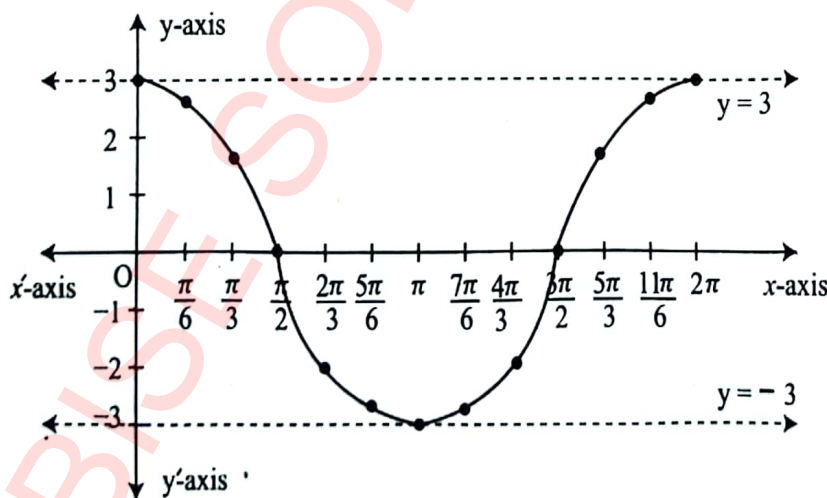

Characteristics

- Domain = $(-\infty, \infty) = \mathbb{R}$
- Range = $[-3, 3]$
- Period = 2π
- Amplitude = 3
- Nature = even function

vii.

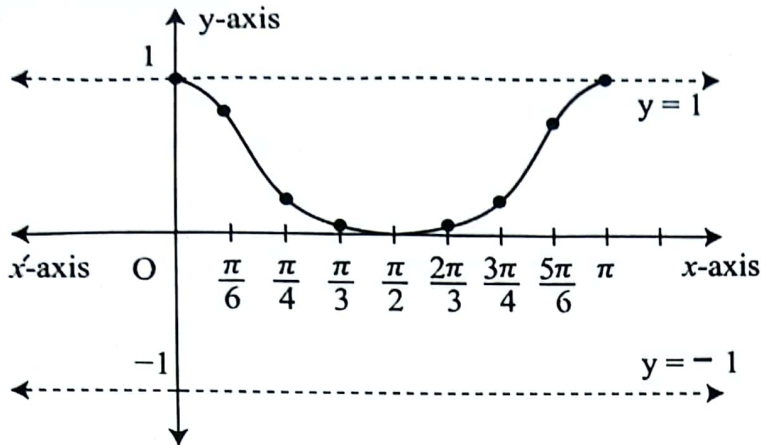

Characteristics

- Domain = $(-\infty, \infty) = \mathbb{R}$
- Range = $[0, 1]$
- Period = π
- Amplitude = 1
- Nature = even function

viii.

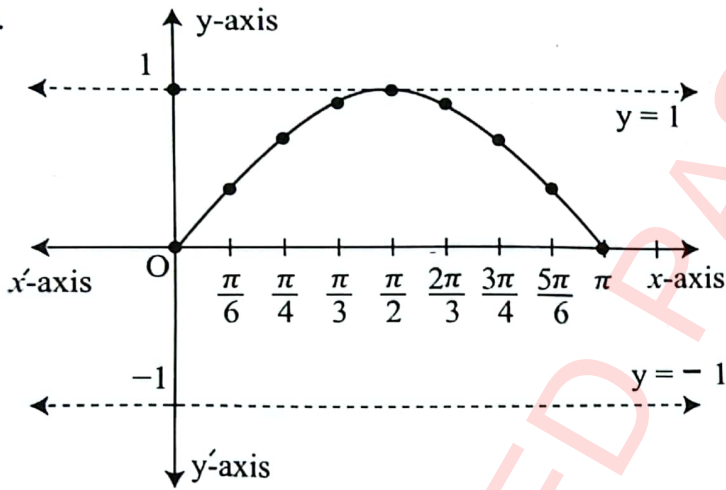

Characteristics

- Domain = $(-\infty, \infty) = \mathbb{R}$
- Range = $[0, 1]$
- Period = π
- Amplitude = 1
- Nature = even function

ix.

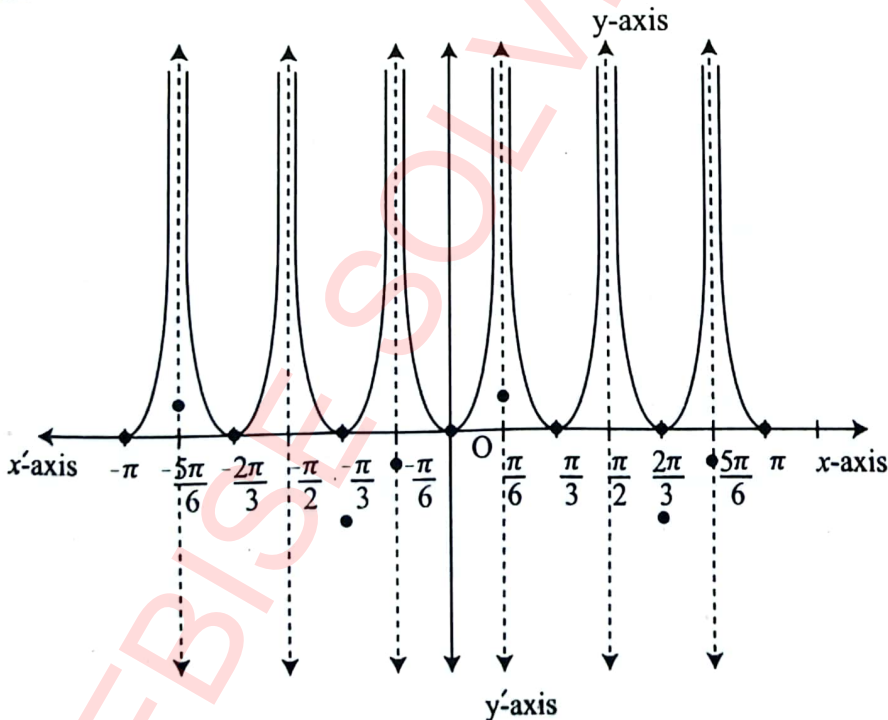

Characteristics

- Domain = $\pi n \leq x < \frac{\pi}{2} + \pi n$
- Range = $f(x) \geq 0$
- Period = π
- Amplitude = nil
- Nature = even function

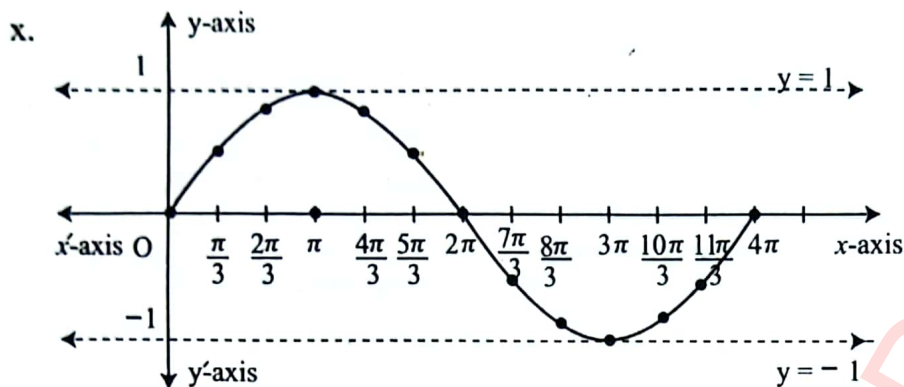

Characteristics

- Domain = $(-\infty, \infty) = \mathbb{R}$
- Range = $[-1, 1]$
- Period = 2π
- Amplitude = 1
- Nature = even function

6. i. π ii. $\frac{2\pi}{5}$ iii. 4π iv. $\frac{2\pi}{3}$ v. π vi. 2π

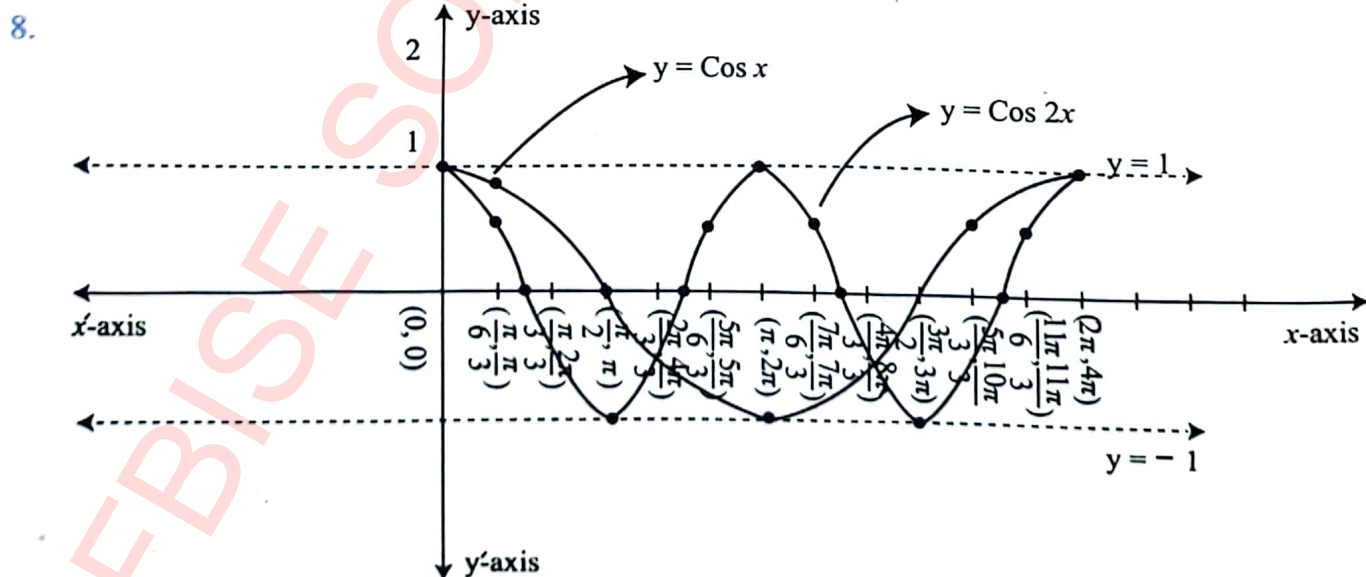
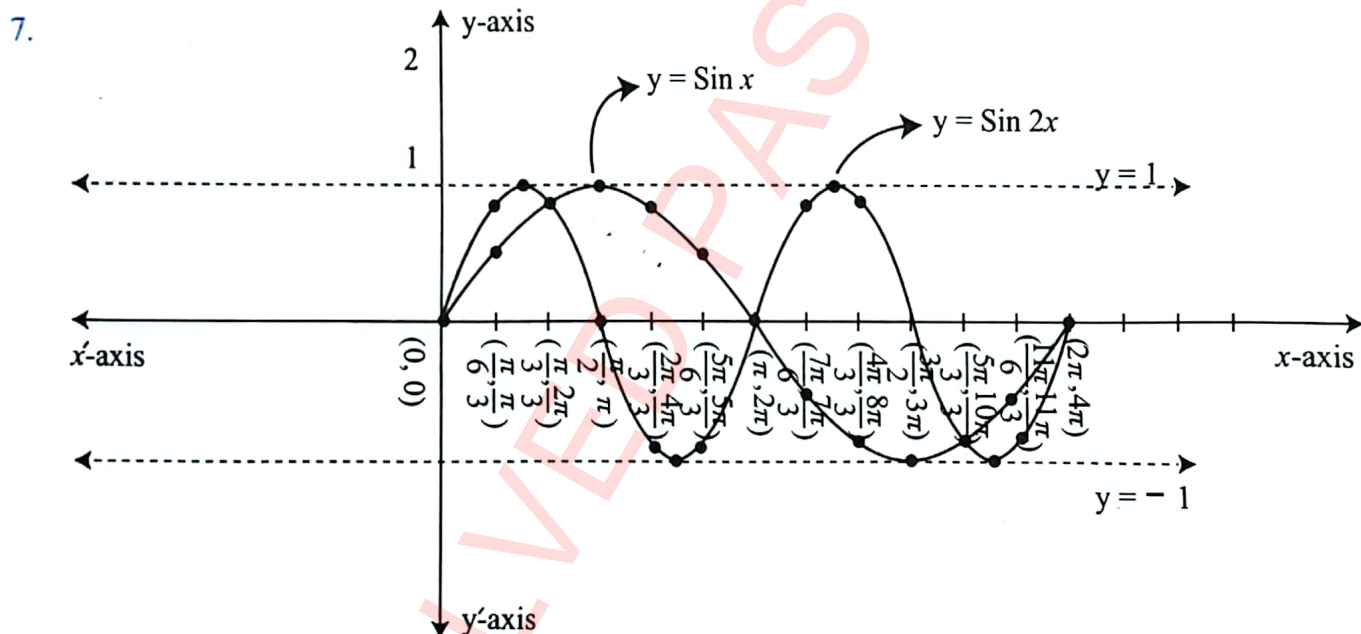

9. i.

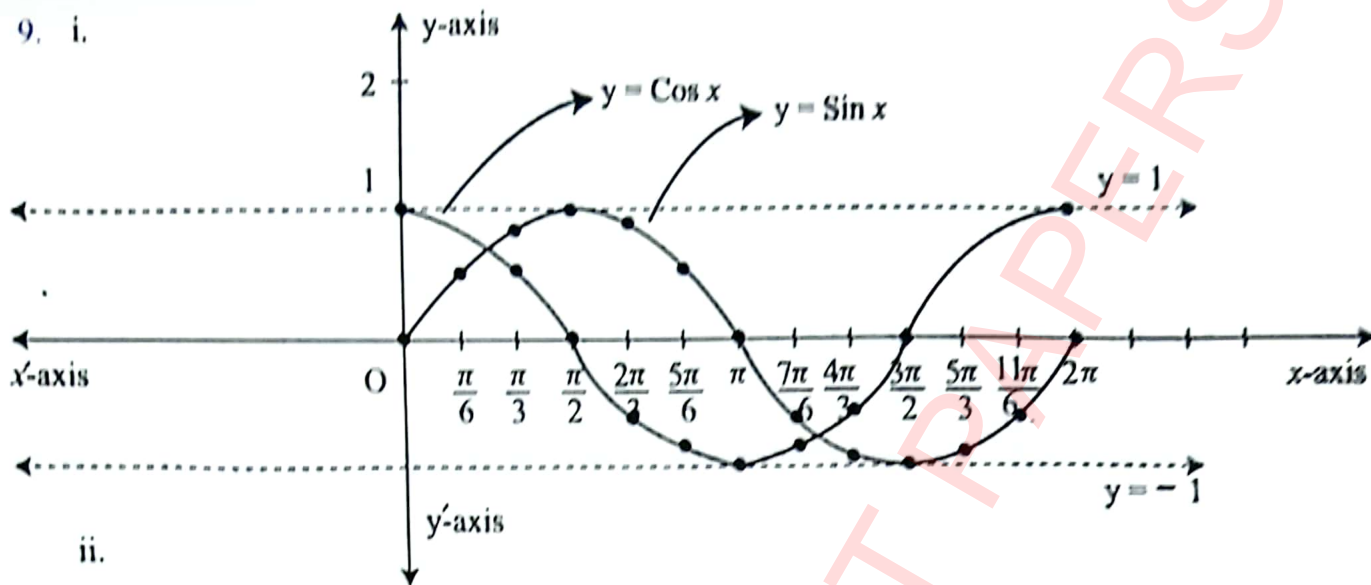

ii.

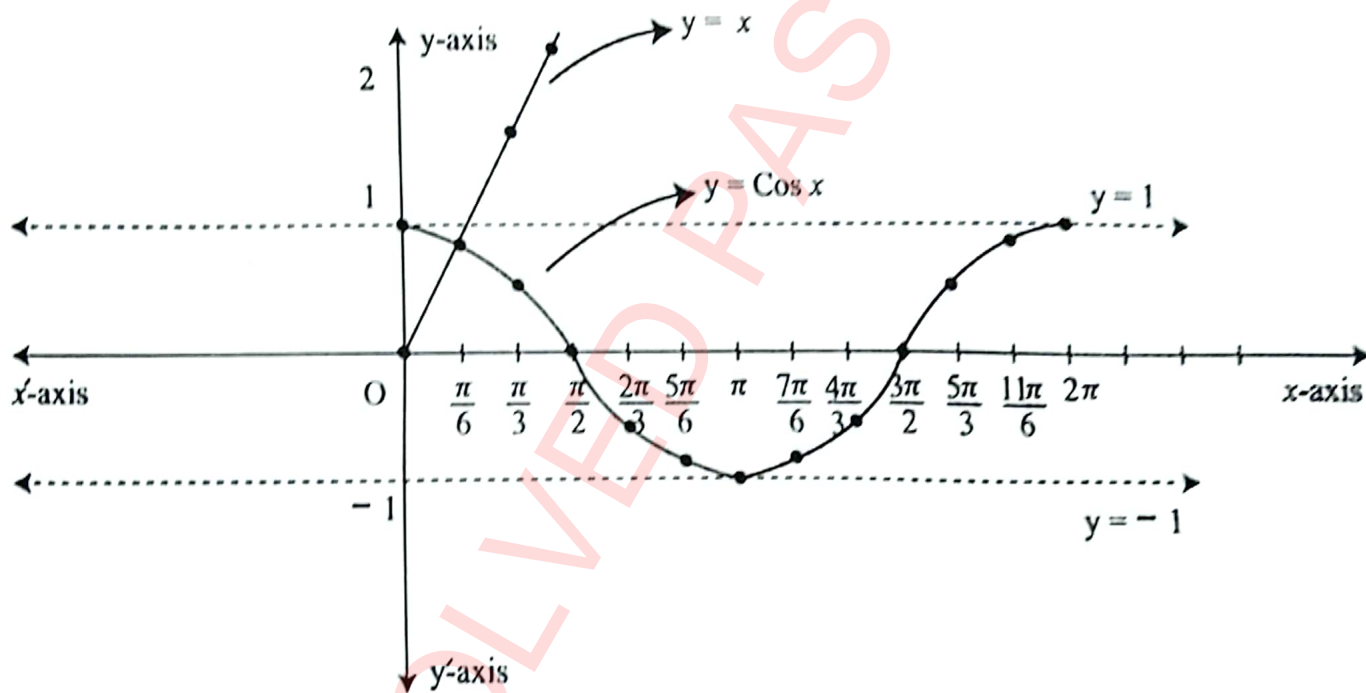

iii.

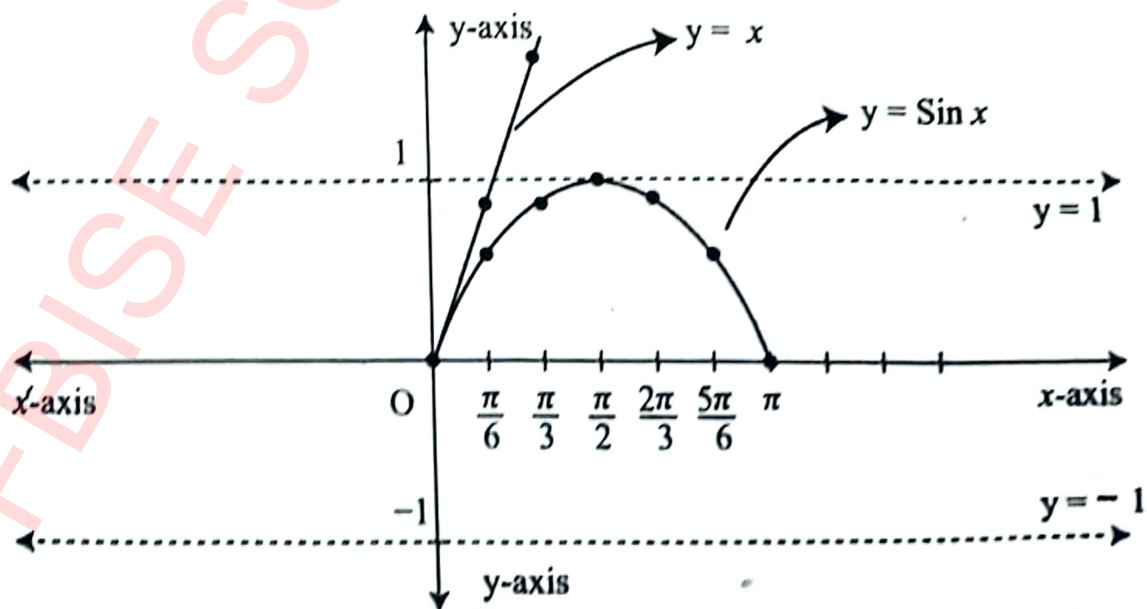

iv.

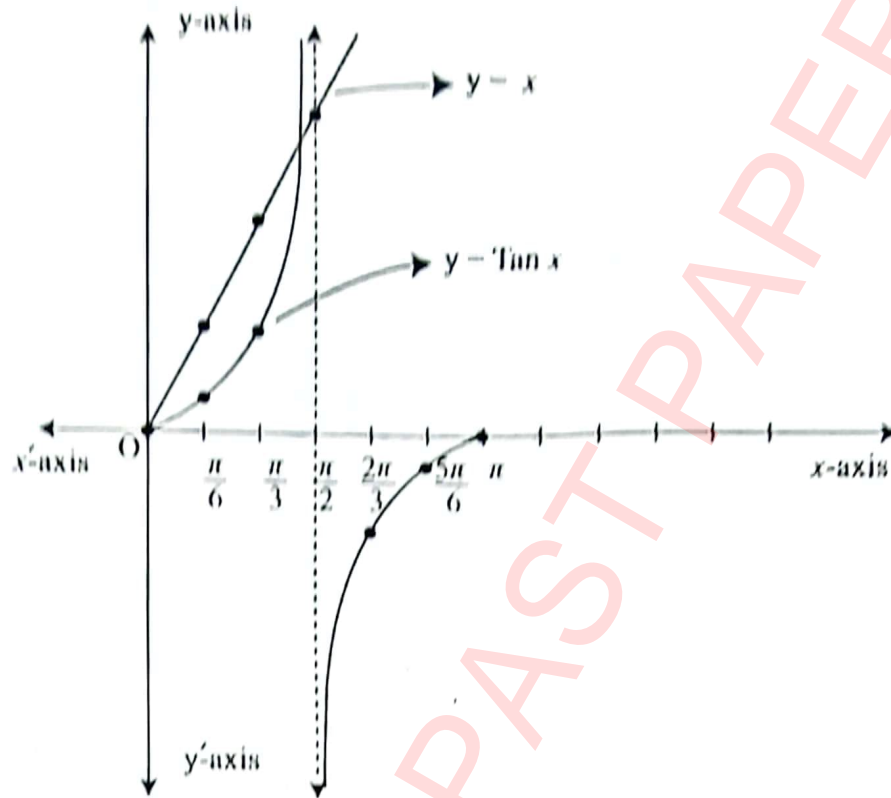

- a. each cycle is $\frac{1}{56}$ second
- b. $k = 20,160$
- c. 180
- d. $V(t) = 180 \sin 20,160t$

REVIEW EXERCISE

- | | | | | |
|--------|---------|----------|--------|-------|
| i. b | ii. a | iii. c | iv. a | v. c |
| vi. a | vii. a | viii. d | ix. b | x. c |
| xi. a | xii. c | xiii. a | xiv. b | xv. c |
| xvi. b | xvii. a | xviii. c | xix. d | xx. a |

- 7. a. Period = $\frac{\pi}{6}$; Amplitude = -20 ; Vertical shift = 24
- b. $h(t) = -20 \cos \left(\frac{\pi t}{8} \right) + 24$
- c. The height is 32 m after 5 minutes.

8. a. Maximum height = 22 m, Minimum height = 2 m.
 b. The height is 12 m after 30 seconds.
 c. One complete revolution takes place in 120 seconds.
9. a. $y = 10 \sin 1440 t^\circ$, $y = 10 \sin 1440 (t - \frac{1}{16})^\circ$
 b. Domain = $\{t / t \geq 0, t \in R\}$, Range = $\{y / -10 \leq y \leq 10, y \in R\}$

| 10. | Domain | Range | Period |
|-------|---|---------------------------------------|------------------|
| i. | Domain = $] -\infty, \infty [= R$ | Range = $] -\infty, \infty [$ | Non periodic |
| ii. | Domain = $] -\infty, \infty [= R$ | Range = $[-2, 2]$ | 6π |
| iii. | Domain = $] -\infty, \infty [= R$ | Range = $] -\infty, \infty [$ | Non periodic |
| iv. | Domain = $] -\infty, \infty [= R$ | Range = $[-5, 5]$ | $\frac{2\pi}{3}$ |
| v. | Domain = $] -\infty, \infty [= R$ | Range = $[-\frac{1}{2}, \frac{1}{2}]$ | 3π |
| vi. | Domain = $] -\infty, \infty [= R$ | Range = $[-\frac{5}{3}, \frac{5}{3}]$ | $\frac{3\pi}{2}$ |
| vii. | Domain = $] -\infty, \infty [= R$ | Range = 0 | Non periodic |
| viii. | Domain = $] -\infty, \infty [= R$ | Range = $[-7, 7]$ | $\frac{2\pi}{5}$ |
| ix. | Domain = $] -\infty, \infty [= R$ | Range = $] -\infty, \infty [$ | Non periodic |
| x. | Domain = $] -\infty, \infty [= R$ | Range = $] -\infty, \infty [$ | Non periodic |
| xi. | Domain = $] -\infty, \infty [= R$ | Range = $[-9, 9]$ | $\frac{2\pi}{3}$ |
| xii. | Domain = $] -\infty, \infty [= R$ | Range = $[7, 9]$ | $\frac{\pi}{2}$ |
| xiii. | Domain = $] -\infty, \infty [= R$ | Range = $[2, 12]$ | π |
| xiv. | Domain = $] -\infty, \infty [= R$ | Range = $[2, 10]$ | π |
| xv. | Domain = $[2\pi n, \frac{\pi}{2} + 2\pi n]$ | Range = $f(x) \geq \frac{1}{2}$ | 2π |

G L O S S A R Y

Adjoint of a matrix: A matrix of order 2, obtained by interchanging diagonal elements and changing the signs of non-diagonal elements.

Algebraic expression: A statement in which variables or constants or both are connected by arithmetic operations (i.e. +, -, ×, ÷).

Allied angles: The angles connected with basic angles of measure θ by a right angle or its multiple, are called allied angles.

Arithmetic mean: A number M is said to be arithmetic mean between two numbers a and b if a, M, b are in A.P.

Arithmetic sequence: An arithmetic sequence is a sequence in which each term, after the first, is found by adding a constant.

Arithmetic series: The sum of the terms of an arithmetic sequence is called an arithmetic series.

Arithmetico-geometric sequence: This sequence is the result of term-by-term multiplication of a geometric progression with the corresponding terms of arithmetic progression.

Column: The vertical arrangement of objects.

Column matrix: A matrix having only one column.

Combination: If in the arrangements of objects their order is not important then this arrangement of objects is called combination.

Complex number: The number of the form $a + ib$, where a and b are real number and $i = \sqrt{-1}$.

Complex polynomial: If z is a complex variable, then the expression $a_0 + a_1z + a_2z^2 + \dots + a_nz^n$ is called complex polynomial of degree n if $a_n \neq 0$ and n is a non-negative integer.

Conformable for matrix addition: Matrices of same order so that they may be added.

Conformable for matrix multiplication: If number of columns of first matrix is equal to the number of rows of second matrix so that they may be multiplied in that order.

Conformable for matrix subtraction: Matrices of same order, so that they may be subtracted.

Conjugate: Two complex numbers differing only in the sign of their imaginary parts.

Constant polynomial: A polynomial having degree zero is called a constant polynomial.

Consistency criteria: A system of homogeneous linear equations is consistent if $\text{Rank } A = \text{Rank } A_b$.

Consistent system: A system of equations is consistent if it has at least one solution.

Cross product of vectors: The product of vectors resulting in a vector quantity.

Cubic polynomial: A polynomial having degree three is called a cubic

Deductive reasoning: Deductive reasoning is a logical approach where someone moves from general ideas to specific conclusions.

Determinant of a matrix: A number obtained by subtracting the product of non-diagonal elements from the product of diagonal elements, in a square matrix of order two.

Diagonal: A line joining any two vertices of a polygon that are not joined by any of its edges; elements running from the upper left corner to the lower right corner of a square matrix.

Diagonal matrix: A matrix in which all the non-diagonal elements are zero but at least one element of the diagonal is non-zero.

Direction angles: The angles that a non-zero vector \vec{r} makes with the coordinate axes in the positive direction are known as direction angles of \vec{r} .

Direction cosines: Cosines of direction angles are called direction cosines.

Domain of trigonometric functions: The domain of a function $f(x)$ is the set of all possible values of 'x' such that function $f(x)$ is defined.

Dot product of vectors: The product of vectors resulting in a scalar quantity.

Equal vectors: Two vectors \vec{a} and \vec{b} are equal if both have the same magnitude and direction.

Equality of complex numbers: Two complex numbers are said to be equal if both have the same real and imaginary parts.

Equality of matrices: Two matrices are equal if both have the same order and the same corresponding elements.

Even function: A function is even if and only if $f(-x) = f(x)$.

Factor theorem: A polynomial $p(x)$ has a factor $x - c$, if and only if $p(c) = 0$.

Factorial: Factorial of an integer n is denoted by $n! = 1 \times 2 \times 3 \dots (n - 1)n$.

Fundamental law of trigonometry: This law is stated as: $\cos(\alpha - \beta) = \cos \alpha \cos \beta + \sin \alpha \sin \beta$

Geometric mean: If a, G, b is in a geometric sequence, then G is called the geometric mean of a and b .

Geometric sequence: A geometric sequence is one in which each term after the first is found by multiplying the previous term by a constant called the common ratio.

Geometric series: The sum of the terms of a geometric sequence is called a geometric series.

Graphic solution: Method of solving two simultaneous equations by plotting the graph of each equation.

Harmonic mean: A number H is said to be the harmonic mean between two numbers a and b if a, H, b are in H.P.

Harmonic sequence: A sequence is called a harmonic sequence if the reciprocals of its terms are in an arithmetic sequence.

Imaginary part: The coefficient i in any complex number.

Inconsistent system: A system of equations that has no solution is called inconsistent.

Inductive reasoning: It is a method of reasoning in which general principle is derived from observations.

Inequality: The relation between two comparable quantities, which are not equal.

Irrational expression: An algebraic expression that is not rational is called an irrational expression.

Linear polynomial: A polynomial having degree one is called a linear polynomial.

Lower triangular matrix: A square matrix in which all the elements lie above the main diagonal are zero.

Matrix: A rectangular arrangement of numbers enclosed within square brackets.

Modulus of a complex number: It is the distance of a complex number from its origin.

Negative of a vector: A vector having the same magnitude but the opposite direction is called the negative of the given vector.

Non-singular matrix: A matrix with non-zero determinant.

Null matrix: A matrix with all entries to be zero.

Odd function: A function is odd if and only if $f(-x) = -f(x)$.

Order of a matrix: If a matrix has m number of rows and n number of columns then the order of the matrix is m -by- n .

Ordered pair: A pair set in which x is designated the first element and y the second, denoted by (x, y) .

Parallel vectors: Two non-zero vectors \vec{a} and \vec{b} are said to be parallel if $\vec{a} = \lambda \vec{b}$.

Periodic function: A periodic function is a function where values repeat after a specific time interval.

Periodicity: The periodic behavior of trigonometric functions is called periodicity.

Permutation: The arrangement of numbers or things in a definite order is called permutation.

Polynomial: Algebraic expressions consisting of one or more terms in which exponents of the variables involved are whole numbers.

Position vector: The vector used to specify the position of a point P with respect to the origin O is called the position vector of P.

Quadratic polynomial: A polynomial having degree two is called a quadratic polynomial.

Range of trigonometric functions: The range of a function $f(x)$ is the set of all possible values of the function $f(x)$ can take, when 'x' is any number from the domain of the function.

Rational expression: An algebraic expression of the form $P(x)/Q(x)$, where $P(x)$ and $Q(x)$ are polynomials and $Q(x) \neq 0$.

Rectangular matrix: A matrix having an unequal number of rows and columns.

Remainder theorem: If a polynomial $p(x)$ is divided by $x - c$, then the remainder is $p(c)$.

Row: Horizontal arrangement of elements.

Row matrix: A matrix having only one row of elements.

Rule of product: If event A can happen in m ways and event B can happen in n ways then pair (A, B) can happen in $m \times n$ or mn ways.

Sequence: A sequence is an arrangement of objects or numbers in a particular order followed by some rule.

Scalar matrix: A diagonal matrix with equal diagonal elements.

Scalar quantity: A physical quantity that can be completely specified by its magnitude only.

Simultaneous equations: Set of equations satisfied by the same solution.

Singular matrix: A matrix with zero determinant.

Skew symmetric matrix: A matrix whose transpose is not equal to the matrix itself.

Solution of equations: The solution of an equation is the process of finding the values of the unknown involved in the equation.

Square matrix: A matrix having an equal number of rows and columns.

Symmetric matrix: A matrix whose transpose is equal to the matrix itself.

Terminating decimal fraction: A decimal fraction whose decimal part is finite.

Transpose of a matrix: A matrix obtained by interchanging rows and columns of a given matrix.

Triangular matrix: A square matrix that is either upper triangular or lower triangular is called a triangular matrix.

Triangular numbers: A triangular number counts objects arranged in an equilateral triangle.

Unit matrix: A diagonal matrix having all diagonal elements equal to one.

Unit vector: A vector that has magnitude 1 is called a unit vector.

Upper triangular matrix: A square matrix in which all the elements lying below the main diagonal are zero.

Vector quantity: A physical quantity that is completely specified by its magnitude and direction.

Zero matrix: A matrix having all elements equal to zero.

Zeros of a polynomial: A value of the variable for which the value of the polynomial is zero.

Zero polynomial: A polynomial having "0" as the only term.

Zero vector: A vector in which the initial and terminal points coincide.

SYMBOLS AND ABBREVIATIONS USED IN MATH

| | | |
|-------------------|---|-----------------------------|
| $=$ | → | is equal to |
| \neq | → | is not equal to |
| \in | → | is member of |
| \notin | → | is not member of |
| \emptyset | → | empty set |
| \cup | → | union of sets |
| \cap | → | intersection of sets |
| \Leftrightarrow | → | if and only if |
| \overline{AB} | → | line Segment AB |
| AB | → | measurement of side AB |
| $\angle A$ | → | measurement of angle A |
| \cong | → | is congruent to |
| \perp | → | is perpendicular to |
| Δ | → | triangle |
| \Rightarrow | → | implies that |
| $\wedge, \&$ | → | and |
| \vee | → | or |
| $<$ | → | is less than |
| $>$ | → | is greater than |
| \leq | → | is less than or equal to |
| \geq | → | is greater than or equal to |
| @ | → | at the rate of |
| % | → | percent |
| π | → | Pie |
| : | → | ratio |
| :: | → | proportion |
| \therefore | → | therefore, hence |
| \because | → | because, since |
| <i>i.e.</i> | → | that is |
| \approx | → | approximately equal to |
| $\sqrt{\quad}$ | → | square root / radical |
| <i>e.g.</i> | → | for example |
| / | → | such that |
| \leftrightarrow | → | corresponding to |
| // | → | is parallel to |
| ! | → | factorial |
| ${}^n P_r$ | → | permutation |
| ${}^n C_r$ | → | combination |

I N D E X

| | | | |
|------------------------------------|-----|---|-----|
| Complex numbers | 06 | Arithmetic sequence | 125 |
| Operations on complex numbers | 06 | Arithmetic mean | 127 |
| Conjugate of complex number | 09 | Arithmetic series | 129 |
| Modulus of complex number | 09 | Geometric sequence | 132 |
| Complex equations | 17 | Geometric mean | 133 |
| Complex polynomials | 19 | Geometric series | 136 |
| Complex quadratic equation | 20 | Harmonic sequence | 140 |
| Polar coordinate system | 21 | Harmonic mean | 141 |
| Polar form of complex number | 21 | Miscellaneous series | 143 |
| Application of complex number | 28 | Arithmetico geometric series | 147 |
| Introduction of matrices | 33 | Remainder theorem | 164 |
| Types of matrices | 33 | Factor theorem | 166 |
| Algebra of matrices | 37 | Factorial notation | 173 |
| Determinants | 45 | Permutations | 176 |
| Multiplicative inverse of matrix | 48 | Combinations | 181 |
| Properties of determinants | 52 | Mathematical induction | 187 |
| Row and column operations | 61 | Binomial theorem | 193 |
| Rank of matrix | 63 | Binomial series | 199 |
| System of linear equations | 65 | Fundamental law of trigonometry | 208 |
| Augmented matrix | 69 | Trigonometric ratios of allied angles | 211 |
| Application of matrices | 75 | Double and half angle identities | 216 |
| Introduction of vectors | 82 | Triple angle identities | 217 |
| Addition of vectors | 83 | Sum and difference formulae | 222 |
| Subtraction of vectors | 82 | Product formulae | 223 |
| Application of vectors in geometry | 84 | Domain of trigonometric functions | 229 |
| Algebra of vectors in space | 86 | Range of trigonometric functions | 229 |
| Dot product of vectors | 93 | Periodicity of trigonometric functions | 233 |
| Direction angles and cosines | 96 | Maximum and minimum values | 237 |
| Work done | 102 | Graphs of trigonometric functions | 240 |
| Cross product of vectors | 104 | Even and odd trigonometric functions | 252 |
| Scalar triple product | 112 | Applications of trigonometric functions | 253 |
| Introduction of sequence | 122 | | |

Approved by National Curriculum Council, Secretariat
Ministry of Federal Education & Professional Training
vide letter No.F.No.1-1(2024)-NCC/DEA/Dir/English, Dated: March 04, 2024

قومی ترانہ

پاک سرزمین شاد باد! شہرِ حسین شاد باد!
تو لہانِ عزمِ عالی شان ارضِ پاکستان
مسدِ یقین شاد باد!

پاک سرزمین کا نظام قوتِ اخوتِ عوام
قوم، ملک، سلطنت پائندہ تابندہ باد!
شاد باد منزلِ مسرور!

پرچمِ ستارہ و ہلال رہبرِ ترقی و کمال
ترجمانِ ماضی، شانِ حال جانِ استقبال
سایہٴ خدا سے ڈو الجبال!



National Book Foundation
as
Federal Textbook Board
Islamabad

